

INSTALLATION MANUAL

MONTAGEANLEITUNG
INSTRUCTIONS DE MONTAGE
ISTRUZIONI PER IL MONTAGGIO

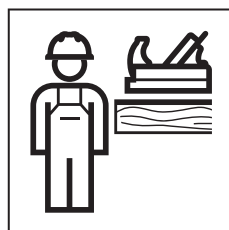

971.763.00.0(00)





GEFAHR

Unsachgemäße Montage

Herabfallen des Produkts kann zu schweren Verletzungen führen.

- ▶ Vor der Montage die Tragfähigkeit der Wand prüfen.
- ▶ Vor der Montage prüfen, ob das mitgelieferte Befestigungsmaterial für den Wandtyp geeignet ist. Das Befestigungsmaterial bei Bedarf austauschen.



DANGER

Incorrect installation

If the product falls from a height it can lead to serious injuries.

- ▶ Check the bearing capacity of the wall before installation.
- ▶ Before installation, check whether the supplied fastening material is suitable for the type of wall in question. If necessary, replace the fastening material.



DANGER

Montage inapproprié

La chute du produit peut entraîner des blessures graves.

- ▶ Avant le montage, vérifier la portance de la paroi.
- ▶ Avant le montage, vérifier que le matériel de fixation convient au type de paroi. Au besoin, remplacer le matériel de fixation.



NIEBEZPIECZEŃSTWO

Nieprawidłowy montaż

Spadnięcie produktu może prowadzić do ciężkich obrażeń.

- ▶ Przed montażem sprawdzić nośność ściany.
- ▶ Przed montażem sprawdzić, czy dostarczone elementy mocujące są przeznaczone do danego typu ściany. W razie potrzeby wymienić elementy mocujące.



NEBEZPEČENSTVO

Neodborná montáž

Spadnutie výrobku môže viesť k ťažkým zraneniam.

- ▶ Pred montážou skontrolujte nosnosť steny.
- ▶ Pred montážou skontrolujte, či dodaný pripevňovací materiál je vhodný pre príslušný typ steny. V prípade potreby vymeňte pripevňovací materiál.



NEBEZPEČÍ

Neodborná montáž

Pád výrobku může způsobit těžké úrazy.

- ▶ Před montáží zkontrolujte nosnost stěny.
- ▶ Před montáží zkontrolujte, zda je dodaný upevňovací materiál vhodný pro daný typ stěny. V případě potřeby upevňovací materiál vyměňte.



OHT

Asjatundmatu paigaldus

Toote allakukkumine võib põhjustada raskeid vigastusi.

- ▶ Enne paigaldamist kontrollige seina kandevõimet.
- ▶ Enne paigaldamist kontrollige, kas kaasapandud kinnitusmaterjal sobib seina tüübiga. Vajadusel asendage kinnitusmaterjal.



BĪSTAMI

Nelietpratīga montāža

Produkta nokrišana var izraisīt smagas traumas.

- ▶ Pirms montāžas pārbaudiet sienas nestspēju.
- ▶ Pirms montāžas pārbaudiet, vai piegādes komplektā iekļautais stiprinājuma materiāls ir piemērots sienas tipam. Stiprinājuma materiālu nepieciešamības gadījumā nomainiet.



PAVOJINGA

Netinkamas montavimas

Nukritęs gaminys gali sukelti sunkius kūno sužalojimus.

- ▶ Prieš montavimą patikrinkite sienos atsparumą apkrovai.
- ▶ Prieš montavimą patikrinkite, ar patiekta tvirtinimo medžiaga pritaikyta sienos tipui. Jeigu būtina, tvirtinimo medžiagą pakeiskite.



PERICOL

Montaj incorect

Căderea produsului se poate solda cu leziuni grave.

- ▶ Înaintea montajului, verificați capacitatea portantă a peretelui.
- ▶ Înaintea montajului, verificați dacă materialul de fixare livrat este adecvat pentru tipul de perete respectiv. La nevoie, înlocuiți materialul de fixare.

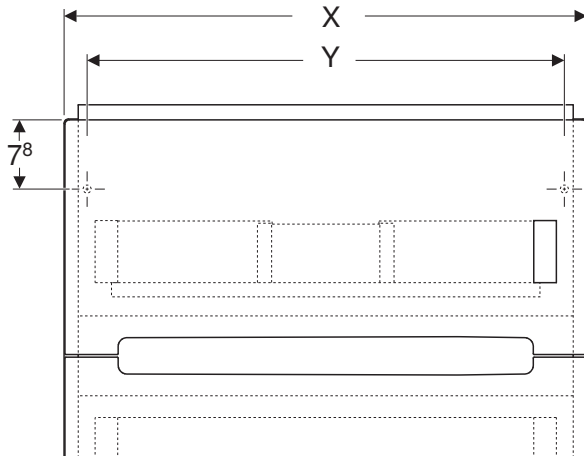

X	Y
49	43 ⁸
59	53 ⁸
79	73 ⁸
99	93 ⁸

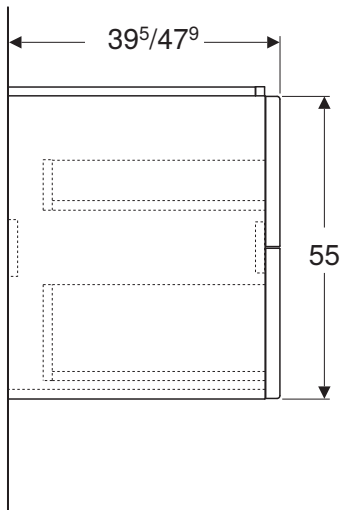



1

1

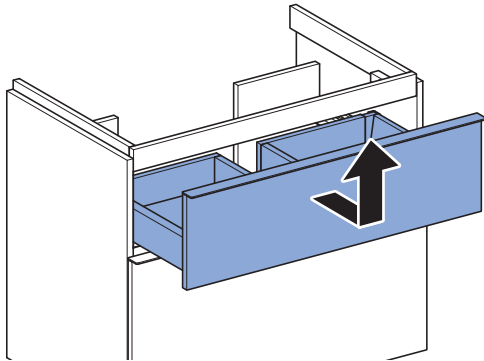

i

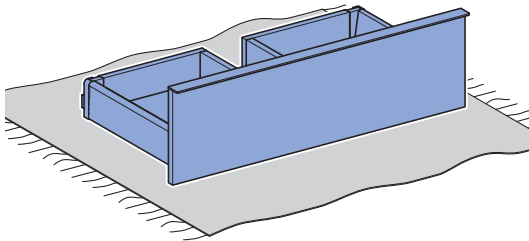

2

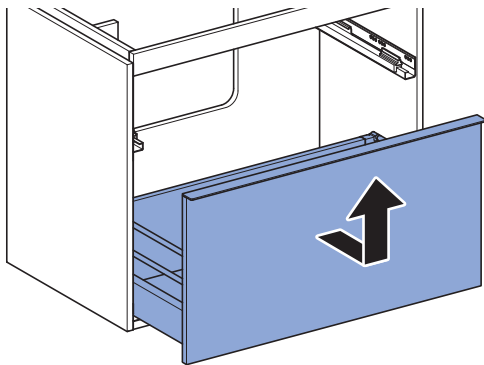

i

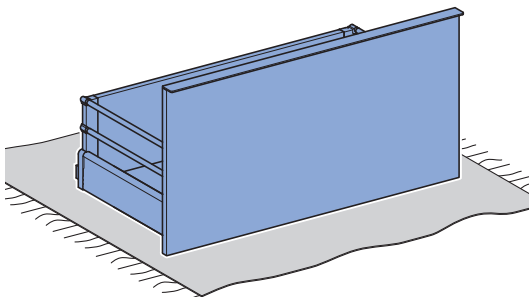

2

1

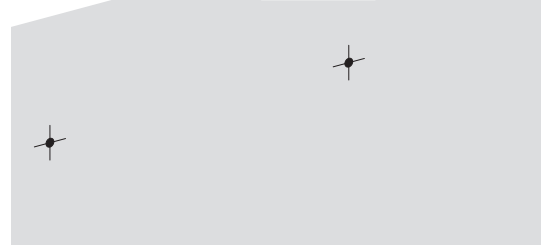
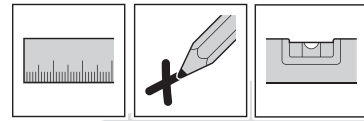

2

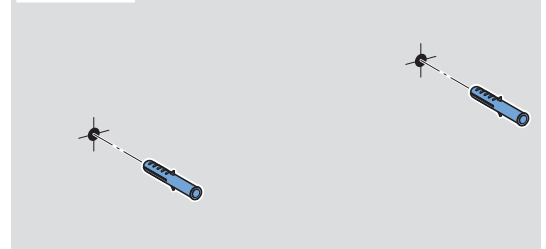

3

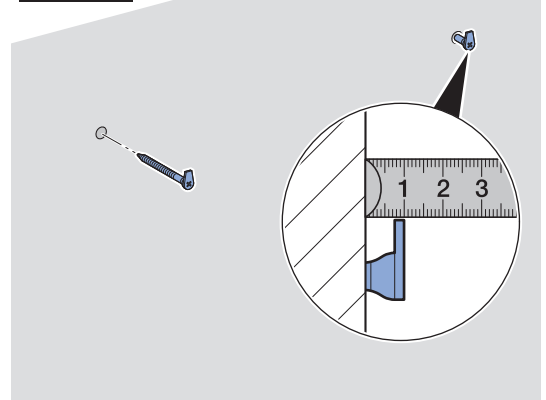
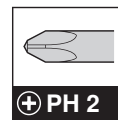

4

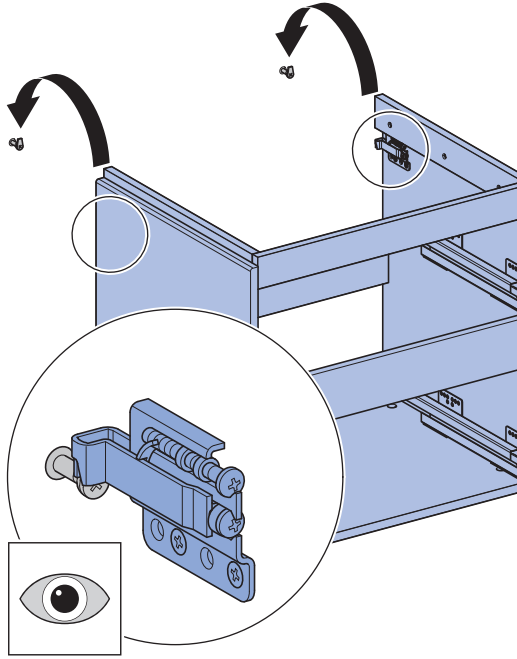

i

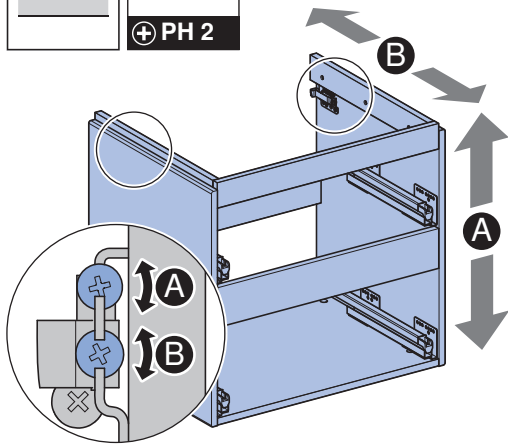
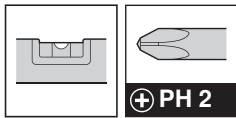

3

1

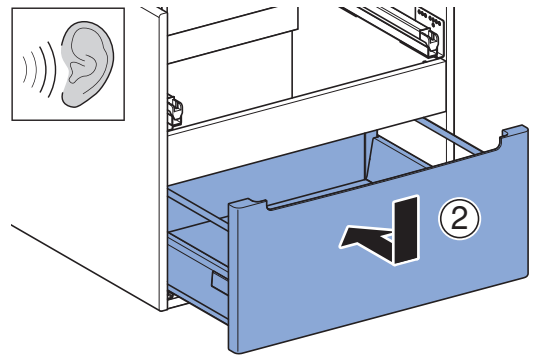
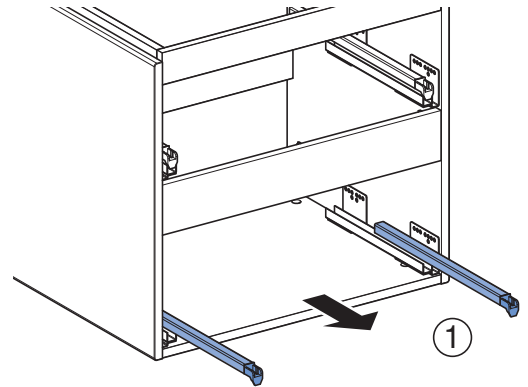

2

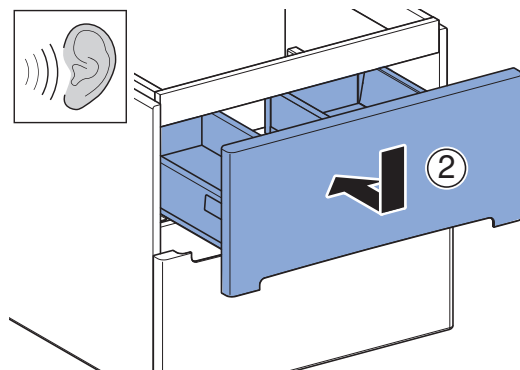
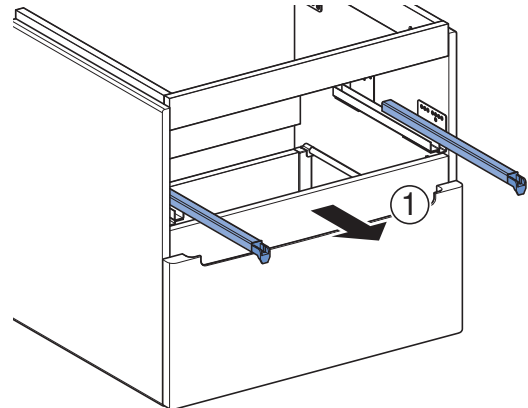

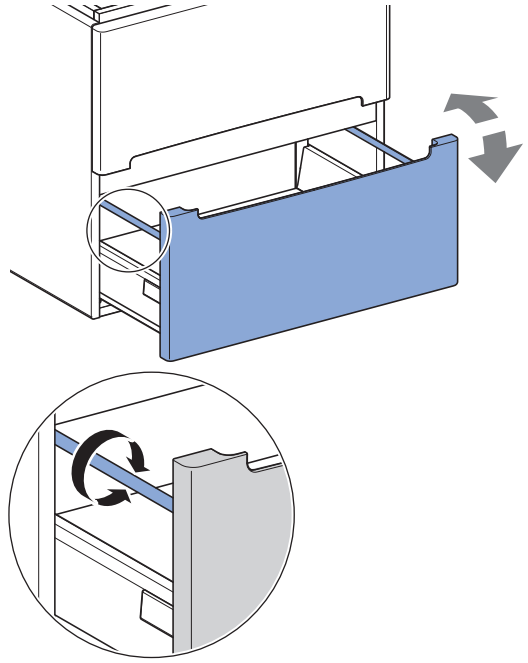
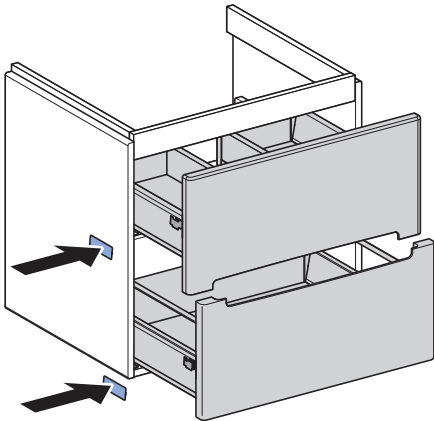
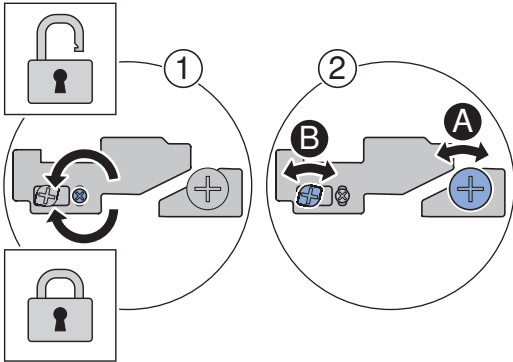
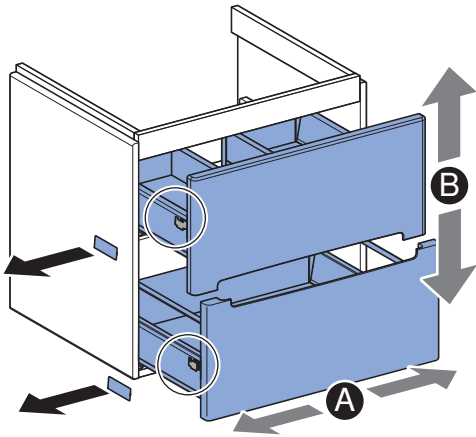
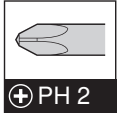

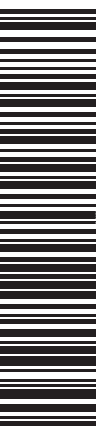

Geberit International AG
Schachenstrasse 77, CH-8645 Jona
documentation@geberit.com
www.geberit.com