



HyTouch

DE	Instandhaltungsanleitung	3
EN	Maintenance Manual	15
FR	Manuel d'entretien	27
IT	Istruzioni per la manutenzione	39
NL	Onderhoudshandleiding	51
ES	Instrucciones de mantenimiento	63
PT	Instruções de manutenção	75
DK	Vedligeholdelsesvejledning	87
NO	Vedlikeholdshåndbok	99
SE	Underhållsanvisning	111
FI	Huolto-ohje	123
IS	Viðhaldshandbók	135
PL	Instrukcja serwisowa	147
HU	Karbantartási útmutató	159
SK	Návod na údržbu	171
CZ	Návod na údržbu	183
SL	Navodila za vzdrževanje	195
HR	Upute za održavanje	207
SR	Uputstvo za održavanje	219
EE	Hooldusjuhend	231
LV	Tehniskā stāvokļa uzturēšanas pamācība	243
LT	Priežiūros instrukcija	255
BG	Ръководство за поддръжка	267
RO	Instrucțiuni pentru lucrări de întreținere	279
GR	Εγχειρίδιο συντήρησης	291
TR	Bakım kılavuzu	303
RU	Руководство по поддержанию в исправном состоянии	315
CN	册熔錶穉	327

Allgemeine Hinweise

- Diese Betriebsanleitung** Die Betriebsanleitung aufbewahren und bei Bedarf einer Fachkraft zur Verfügung stellen.
- Betrieb, Wartung** Wartungsarbeiten dürfen nur so weit durch den Betreiber ausgeführt werden, wie in dieser Anleitung beschrieben.
- Service** Servicearbeiten dürfen nur durch eine Fachkraft durchgeführt werden. Unsachgemäße Arbeiten können zu Unfällen, Sachschäden und Betriebsstörungen führen.





Zielgruppe

Dieses Dokument richtet sich an Fachkräfte gemäss EN EC 62079:2001.

Bestimmungsgemässe Verwendung

Die HyTouch Urinalsteuerungen sind zum Spülen von Urinalkeramiken bestimmt. Bei Zweckentfremdung sind Gewährleistungsansprüche und Haftungsansprüche bei Personenschäden und Sachschäden ausgeschlossen.

Symbolerklärung

Symbol	Bedeutung
	VORSICHT Weist auf eine mögliche gefährliche Situation hin, die leichte oder mittlere Körperverletzung oder Sachschaden zur Folge haben kann.
	Schmierfett verwenden!
	Leitungswasser ist abgestellt
	Leitungswasser ist angestellt

Kontakt

Bei Fragen oder Problemen kontaktieren Sie Ihre zuständige Geberit Vertriebsgesellschaft oder www.geberit.com.

Aufbau

HyTouch Urinalsteuerung Pneumatik

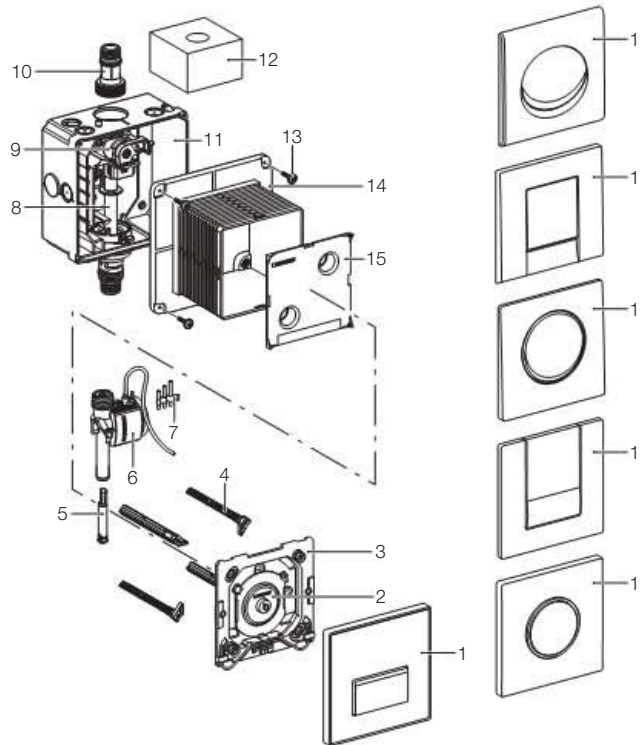

- 1 Betätigungsplatte
- 2 Pneumatischer Drücker
- 3 Befestigungsrahmen
- 4 Distanzbolzen
- 5 Durchflussbegrenzer
- 6 Pneumatikventil
- 7 Düsenatz
- 8 Leerrohr
- 9 Absperrventil mit Drossel
- 10 Anschlussnippel
- 11 UP-Gehäuse
- 12 Schutzschwamm
- 13 Befestigungsschrauben
- 14 Bauschutz
- 15 Bauschutzdeckel

Wartung

Wartungsintervall

Folgende Wartungsarbeiten bei Bedarf, spätestens aber in den angegebenen Intervallen durchführen:

- Oberfläche der Betätigungsplatte reinigen - wöchentlich durch den Betreiber
- Korbfilter reinigen - alle 2 Jahre durch eine Fachkraft

Wartungsarbeiten

Betätigungsplatte reinigen



VORSICHT

Aggressive und scheuernde Reinigungsmittel können die Oberfläche beschädigen.

- ▶ Keine chlorhaltigen, säurehaltigen, schleifenden oder ätzenden, sondern nur milde Reinigungsmittel und Wasser verwenden



Reklamationen, die durch unsachgemäße Behandlung mit Reinigungsmitteln verursacht werden, können nicht anerkannt werden.

Korbfilter reinigen oder ersetzen



Service

Fehlersuche

Problem	Mögliche Ursache	Abhilfe
Wasser fließt nicht	Wasserzufuhr ist geschlossen	Wasserzufuhr öffnen
	Korbfilter ist verstopft oder verschmutzt	Korbfilter reinigen oder ersetzen • Siehe "Wartung, Korbfilter reinigen oder ersetzen"
	Kein Druck auf Wassernetz	Wasserdruck prüfen • Wasserdruck wieder herstellen
	Pneumatikschlauch Steckverbindung zwischen Pneumatikdrücker und Pneumatikventil ist getrennt	Pneumatikschlauch Steckverbindung herstellen
	Pneumatikschlauch ist geknickt oder gebrochen	Defekten Pneumatikschlauch ersetzen
Dauerläufer (Wasser stoppt nicht)	Pneumatikventil ist defekt	Pneumatikventil ersetzen • Siehe "Service, Pneumatikventil ersetzen"
		Pneumatikventil ersetzen • Siehe "Service, Pneumatikventil ersetzen"
Urinalkeramik wird ungenügend ausgespült	Drossel ist zu wenig geöffnet	Drossel öffnen
Spülwasser spritzt aus der Urinalkeramik	Zu hoher Durchfluss	Durchflussbegrenzer montieren • Der Durchflussbegrenzer ist als Zubehör erhältlich (242.484.00.1)

Servicearbeiten

Diese Serviceanleitung zeigt die Steuerung mit vertikaler Wasserführung (A). Die Steuerung mit horizontaler Wasserführung (B) ist nicht gezeigt, die Servicearbeiten sind aber die gleichen.

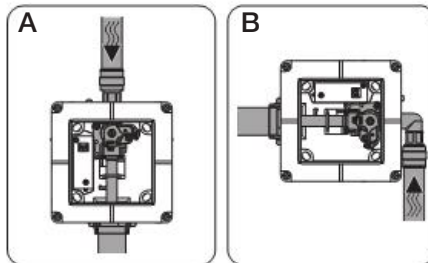

Folgende Servicearbeiten sind hier beschrieben:

- Betätigungsplatte und Befestigungsrahmen demontieren
- Pneumatikventil ersetzen
- Drosselschraube ersetzen
- Lippendichtung Spüleleitung ersetzen
- Befestigungsrahmen und Betätigungsplatte montieren

Betätigungsplatte und Befestigungsrahmen demontieren

1

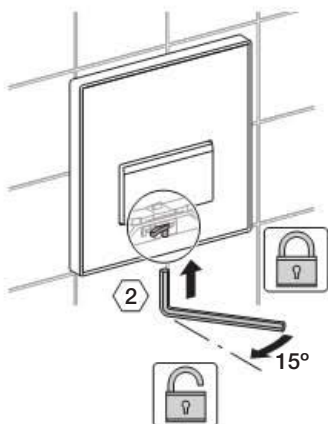

2

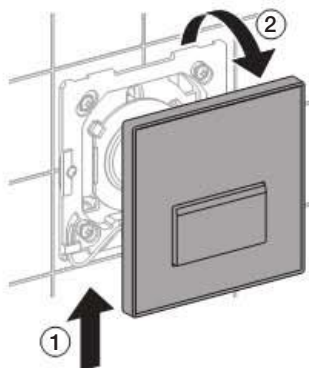

3

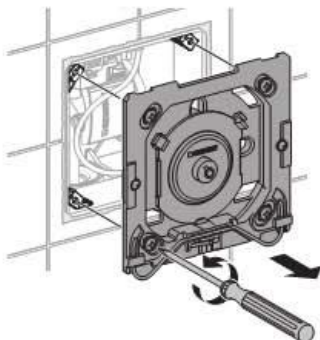

4

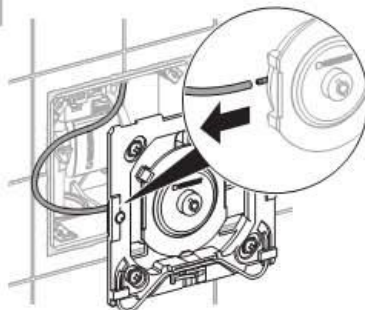

Pneumatikventil ersetzen

Voraussetzungen

Betätigungsplatte und Befestigungsrahmen sind demontiert.

Siehe "Service, Betätigungsplatte und Befestigungsrahmen demontieren".

1

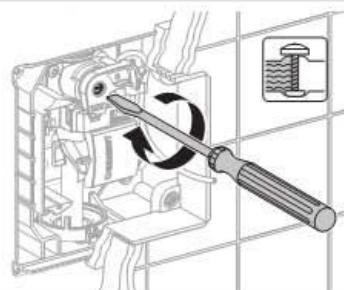

2

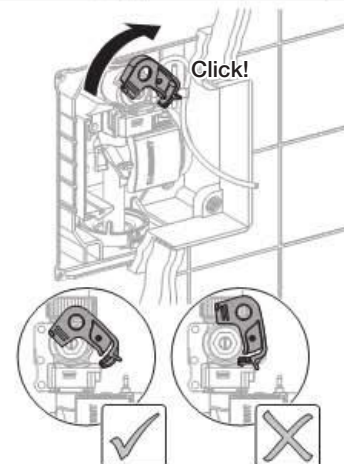

Service

3

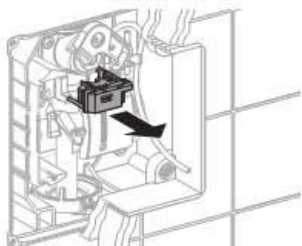

4

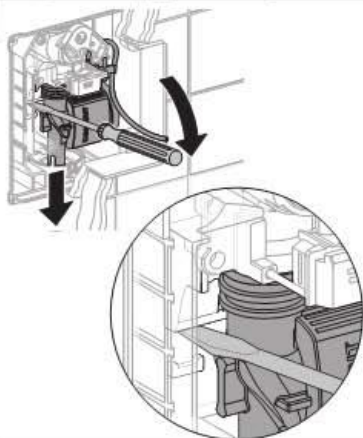

5

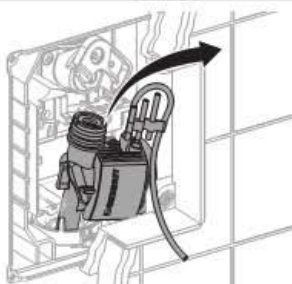

6

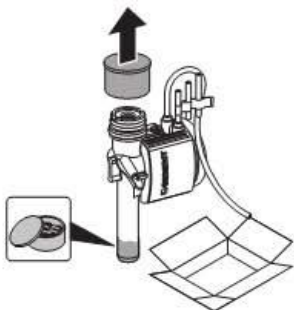

7

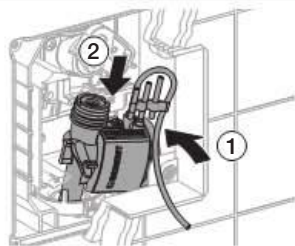

8

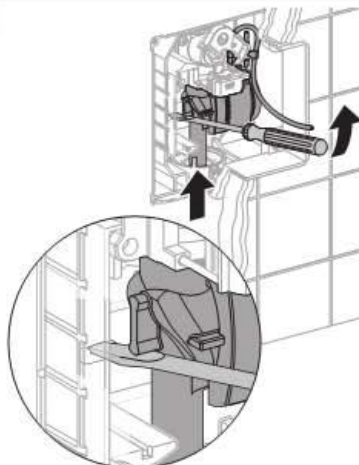

9

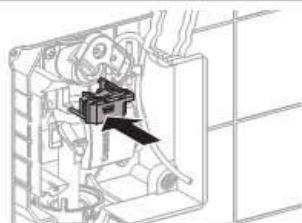

10

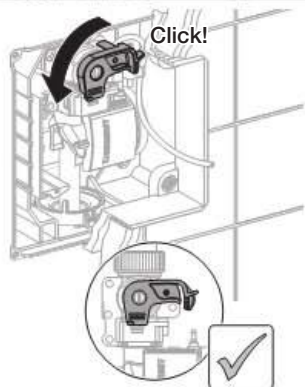

Drosselschraube ersetzen

Voraussetzungen

Betätigungsplatte und Befestigungsrahmen sind demontiert.

Siehe "Service, Betätigungsplatte und Befestigungsrahmen demontieren".

1

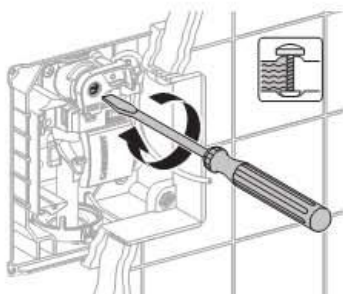

2 Zentrale Wasserzufuhr schliessen.

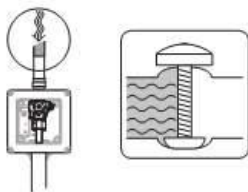

3

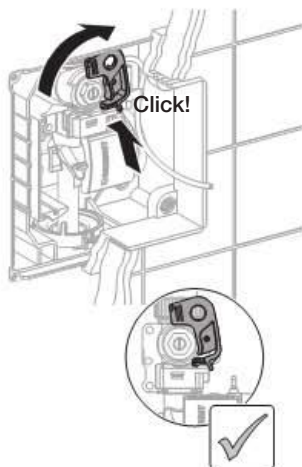

4

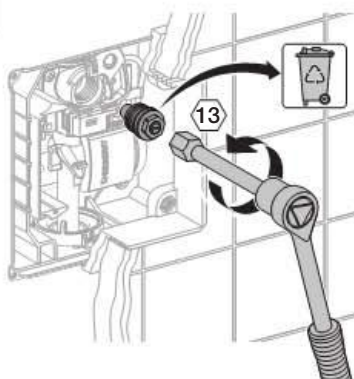

5

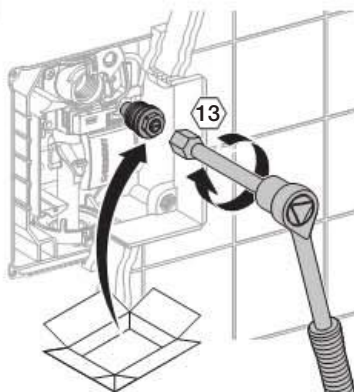

6

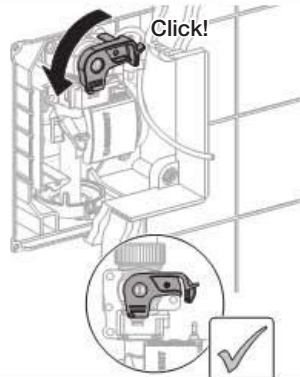

7 Zentrale Wasserzufuhr öffnen.



Lippendichtung Spülleitung ersetzen

Voraussetzungen

Betätigungsplatte und Befestigungsrahmen sind demontiert.

Siehe "Service, Betätigungsplatte und Befestigungsrahmen demontieren".

1

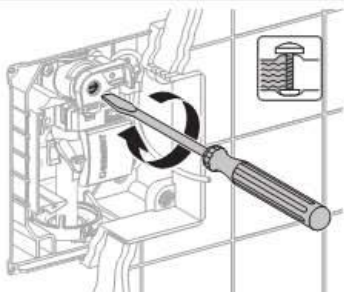

2

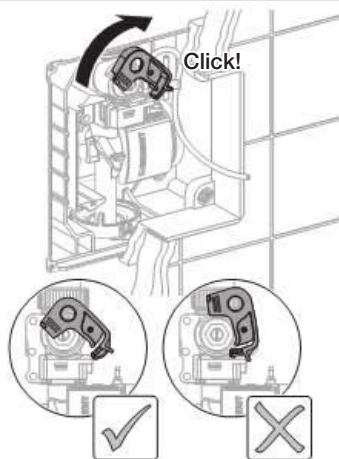

3

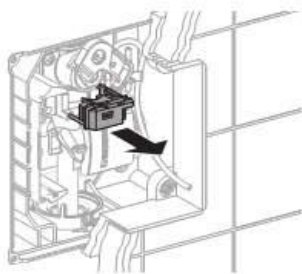

4

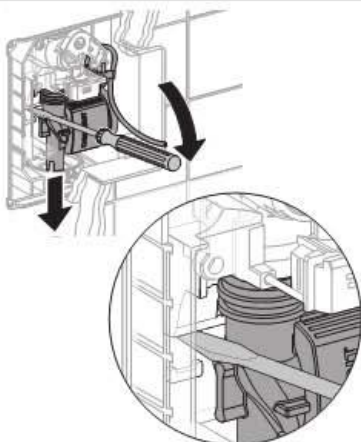

5

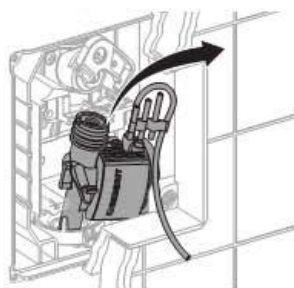

6

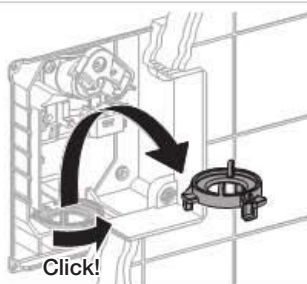

7

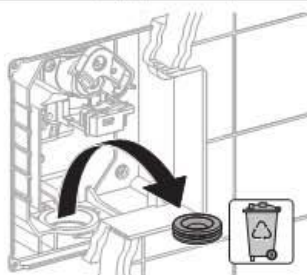

8



9

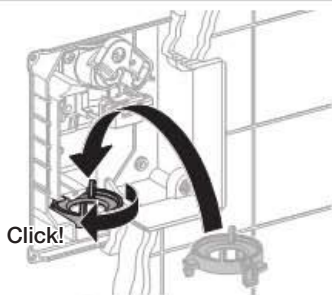

10

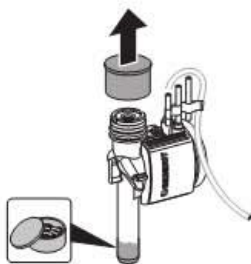

11

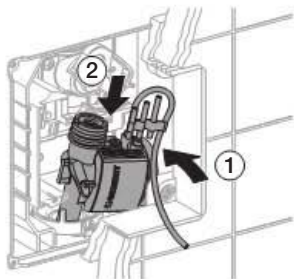

12

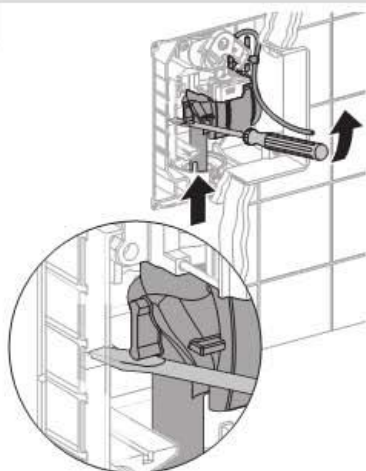

13

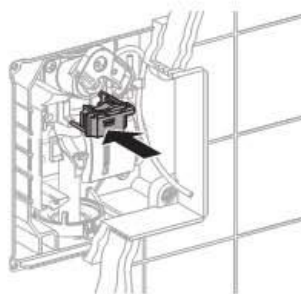

14

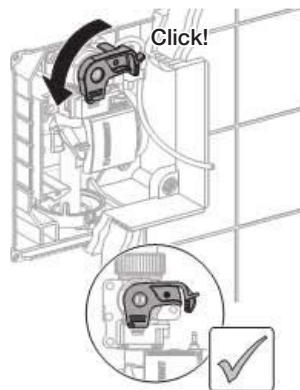

Befestigungsrahmen und Betätigungsplatte montieren

1

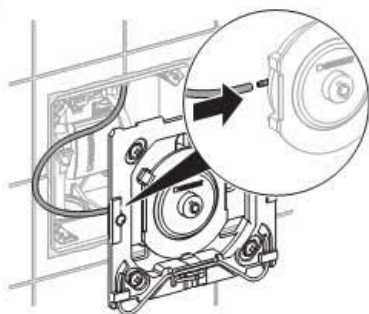

2

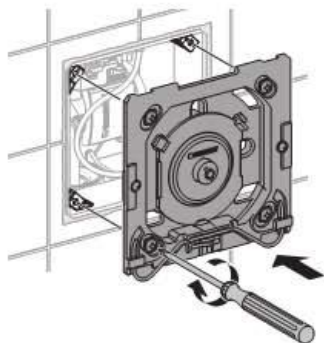

3

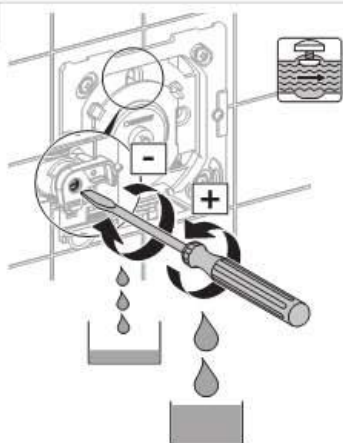

4

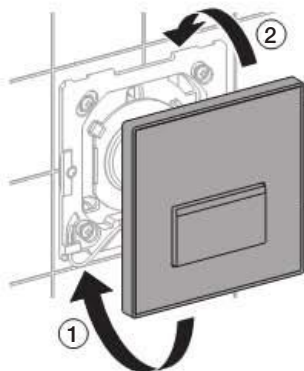

5

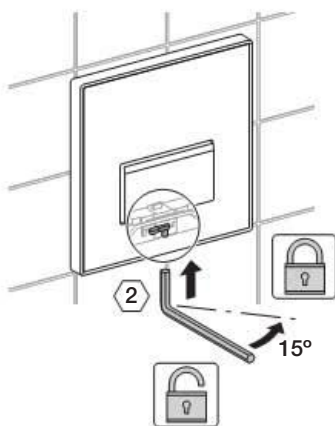

Technische Daten

HyTouch Urinalsteuerung Pneumatik

Durchflussmenge bei 1 bar	0,3 / 0,24 (mit Durchflussbegrenzer) l/s
Prüfdruck Wasser	16 bar
Prüfdruck Luft / Inertgas	3 bar
Betätigungskraft	< 12 N
Spülzeit Einstellbereich	4 / 8 / 12 s
Luftfeuchtigkeit	< 100 % relativ
Druckbereich im Betrieb	1 - 8 bar
Betriebstemperatur Wasser max.	30 °C

General information

These operating instructions

Keep these operating instructions and provide them to skilled persons if necessary.

Operation, maintenance

Maintenance work is only allowed to be performed by the operator as it is described in these instructions.

Service

Repair works are only allowed to be carried out by a skilled person. Incorrect work can lead to accidents, material damage and malfunctions.





Target group

This document is intended for use by skilled persons as defined by EN IEC 62079:2001.

Intended use

HyTouch urinal flush controls are intended to flush urinal ceramics. In the event of misuse, guarantee claims and liability claims for personal injuries and material damage will not be accepted.

Explanation of symbols

Symbol	Meaning
	CAUTION Refers to a potentially dangerous situation that may cause slight or moderate injury or material damage.
	Use lubricating grease!
	Tap water is switched off.
	Tap water is switched on.

Contact

If you have any queries or problems, please contact your Geberit sales company or see www.geberit.com.

Structure

HyTouch urinal flush control pneumatic

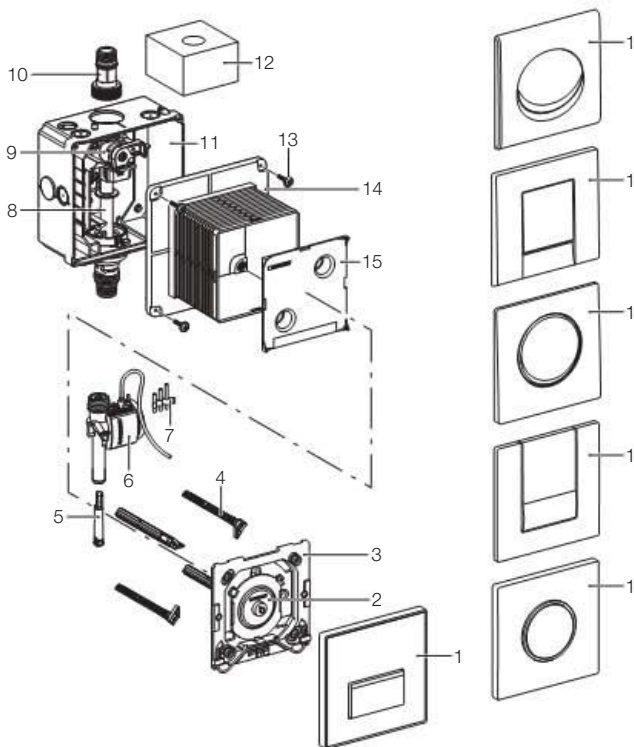

- 1 Actuator plate
- 2 Pneumatic actuator
- 3 Mounting frame
- 4 Distance bolt
- 5 Flow limiter
- 6 Pneumatic valve
- 7 Nozzle set
- 8 Conduit pipe
- 9 Stop valve with throttle
- 10 Connecting nipple
- 11 Concealed housing
- 12 Protective sponge
- 13 Fastening screws
- 14 Protection box
- 15 Protection cover

Maintenance

Maintenance interval

As necessary or at the latest in the specified intervals, the following maintenance work is required:

- Cleaning the actuator plate - every week, to be done by the operator
- Cleaning the basket filter - every 2 years, to be done by a skilled person

Maintenance work

Cleaning the actuator plate



CAUTION

Aggressive and scouring cleaning agents can damage the surface.

- ▶ Never use aggressive cleaning agents that contain chlorine, are acidic, abrasive or corrosive. Only use water and a mild cleaning agent.



We cannot accept any complaints arising from damage caused by improper treatment with cleaning agents.

Cleaning or replacing the basket filter



Service

Troubleshooting

Problem	Possible cause	Fault clearance
Water does not run	Water supply valve is closed	Open the water supply valve
	Basket filter is blocked or dirty	Clean or replace the basket filter • See "Maintenance, Cleaning or replacing the basket filter"
	No pressure in water net	Check the water pressure • Restore the water pressure
	Pneumatic hose plug connection between the pneumatic actuator and the pneumatic valve has been separated	Restore the pneumatic hose plug connection
	Pneumatic hose has been kinked or broken	Replace the defective pneumatic hose
Continuous flow (water does not stop)	Pneumatic valve is defective	Replace the pneumatic valve • See "Service, Replacing the pneumatic valve"
	Throttle is not open sufficiently	Open the throttle
Urinal ceramic is not being flushed out sufficiently	Excessive flow rate	Mount a flow limiter • Flow limiters are available as accessories (242.484.00.1)

Repair works

These service instructions show the control with vertical water guide (A). The control with horizontal water guide (B) is not shown, but the repair works are the same.

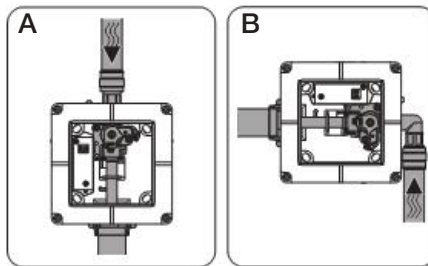

The following repair works are described here:

- Removing the actuator plate and mounting frame
- Replacing the pneumatic valve
- Replacing the regulating screw
- Replacing the lip seal of the flush pipe
- Mounting the mounting frame and actuator plate

Removing the actuator plate and mounting frame

1

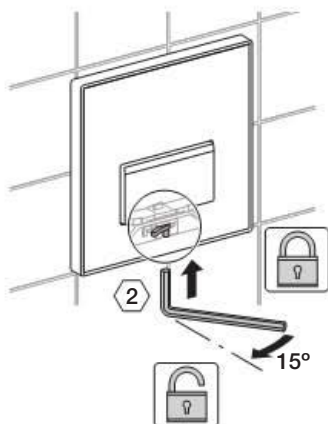

2

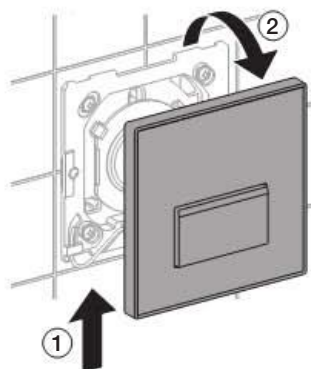

3

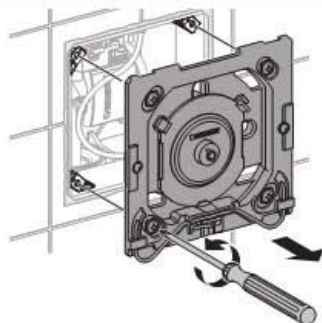

4

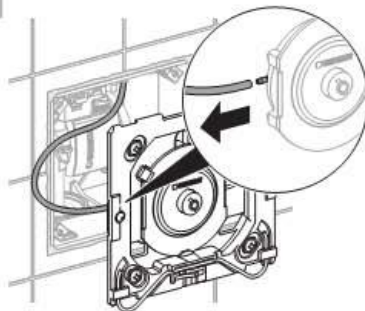

Replacing the pneumatic valve

Prerequisites

Actuator plate and mounting frame have been removed.

See "Service, Removing the actuator plate and mounting frame".

1

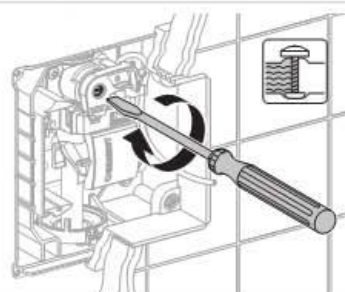

2

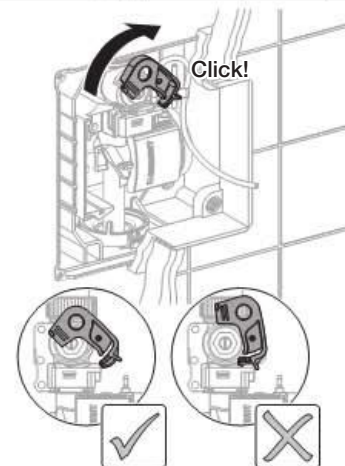

3

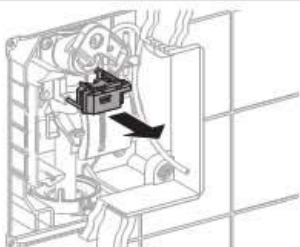

4

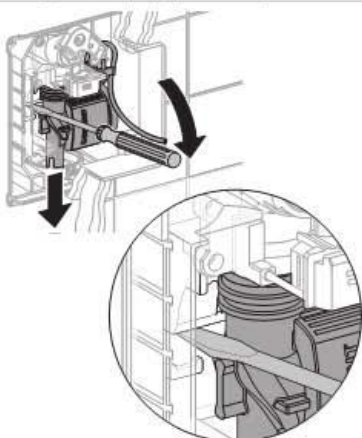

5

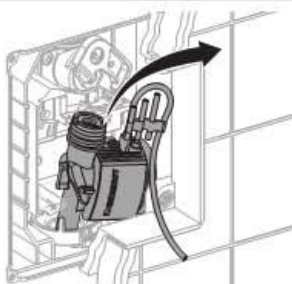

6

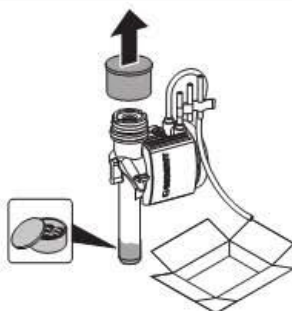

7

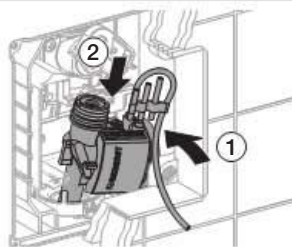

8

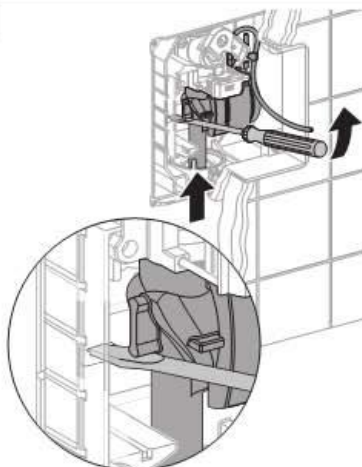

9

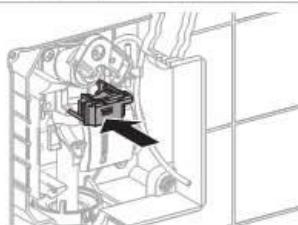

10

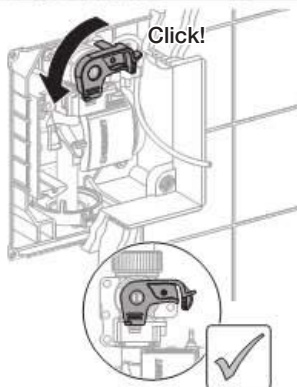

Replacing the regulating screw

Prerequisites

Actuator plate and mounting frame have been removed.

See "Service, Removing the actuator plate and mounting frame".

1

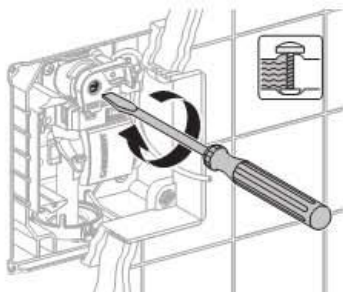

2 Close the central water supply valve.

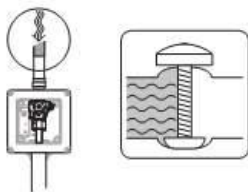

3

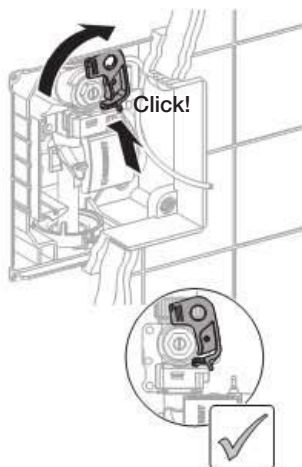

4



5

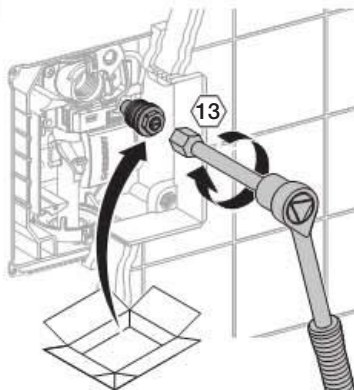

6

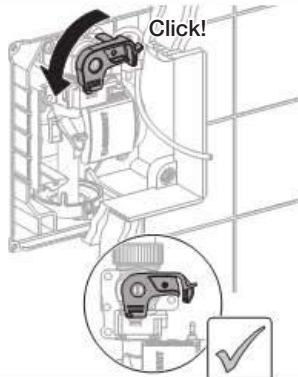

7 Open the central water supply valve.



Replacing the lip seal of the flush pipe

Prerequisites

Actuator plate and mounting frame have been removed.

See "Service, Removing the actuator plate and mounting frame".

1

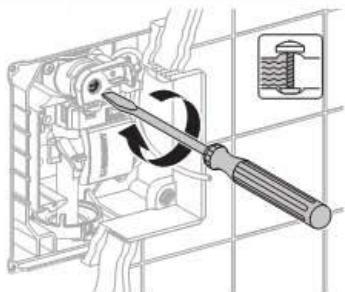

2

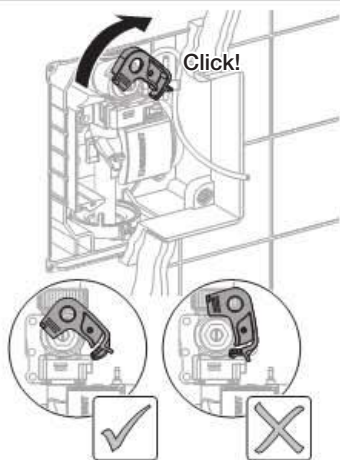

3

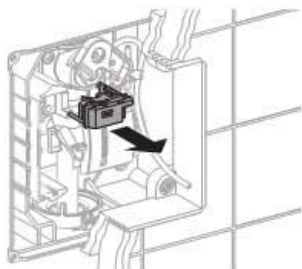

4

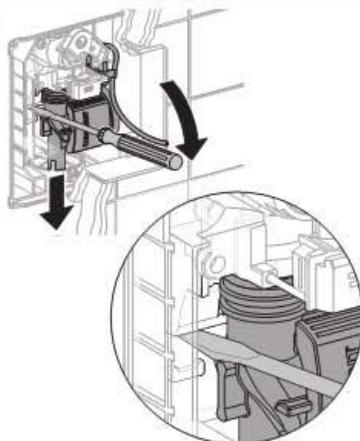

5

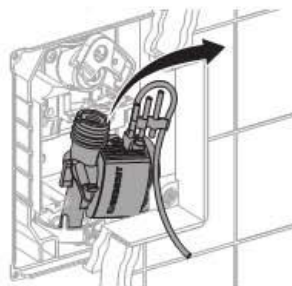

6

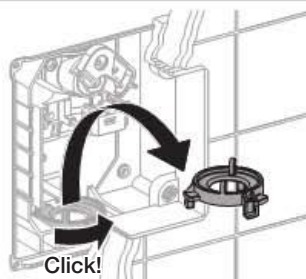

7

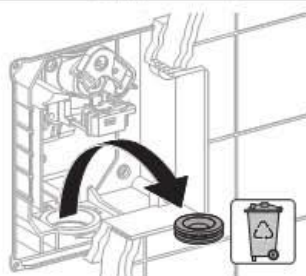

8



9

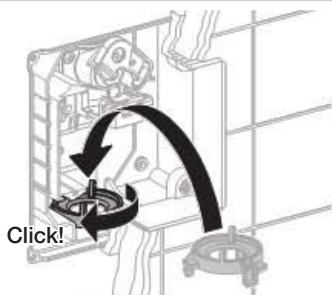

10

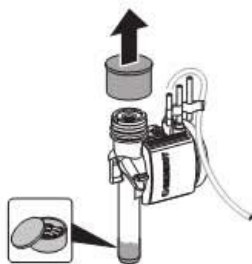

11

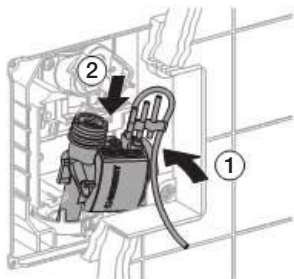

12

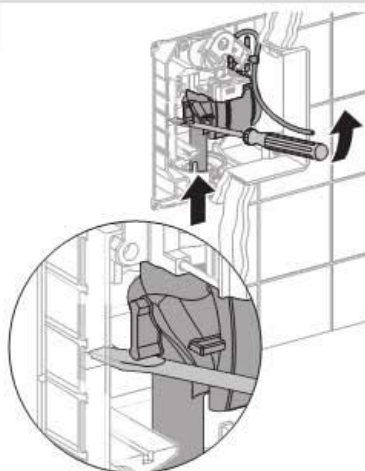

13

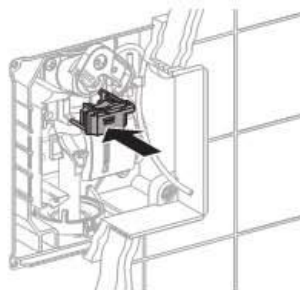

14

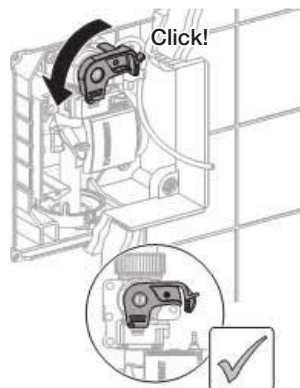

EN

Mounting the mounting frame and actuator plate

1

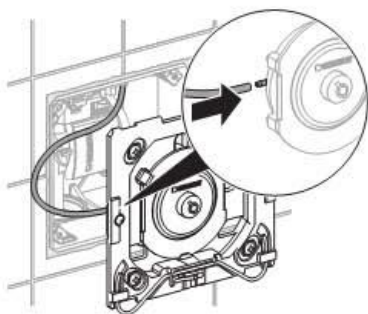

2

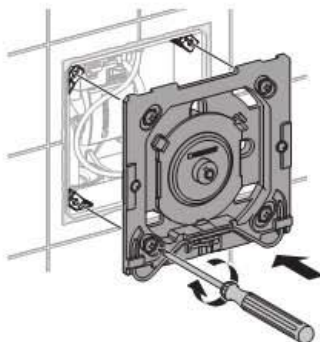

3

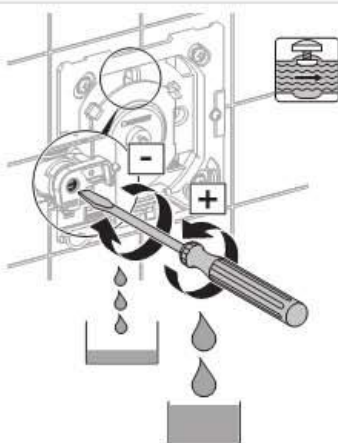

4

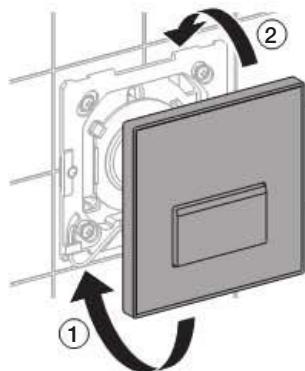

5

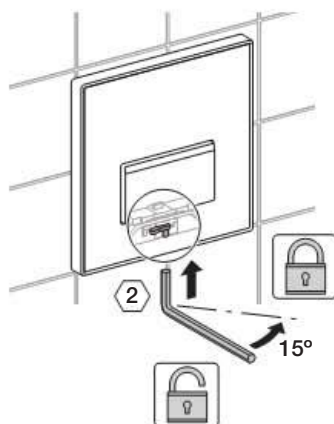

Technical data

HyTouch urinal flush control pneumatic

Flow rate at 1 bar	0.3 / 0.24 (with flow limiter)	l/s
Test pressure water	16	bar
Test pressure air / inert gas	3	bar
Actuation force	< 12	N
Flush time adjustment range	4 / 8 / 12	s
Humidity	< 100	% relative
Pressure range during operation	1 - 8	bar
Operating temperature water max.	30	°C

EN

Indications d'ordre général

Ce mode d'emploi

Conserver le mode d'emploi et le mettre à disposition d'un spécialiste en cas de besoin.

Utilisation, entretien

Les travaux de maintenance doivent être exécutés par l'exploitant uniquement comme il est décrit dans les présentes instructions.

Service

Les travaux de maintenance ne doivent être effectués que par une personne qualifiée. Des travaux inappropriés peuvent provoquer des accidents, des dommages matériels et des dysfonctionnements.





Clientèle visée

Ce document s'adresse aux personnes qualifiées selon EN CEI 62079:2001.

Utilisation conforme

Les commandes d'urinoir HyTouch sont destinées au rinçage des céramiques d'urinoir. En cas d'utilisation détournée, toutes prétentions de garantie et de responsabilité en cas de dommages matériels ou corporels sont exclues.

Explication des symboles

Symbole	Signification
	ATTENTION Signale une situation dangereuse potentielle pouvant entraîner des blessures corporelles légères ou moyennes ou des dommages matériels.
	Utiliser de la graisse !
	L'eau du robinet est coupée
	L'eau du robinet est ouverte

Contact

Pour toutes questions ou en cas de problèmes, veuillez contacter la société de distribution Geberit compétente ou le site Internet www.geberit.com.

Structure

Système pneumatique de la commande d'urinoir HyTouch

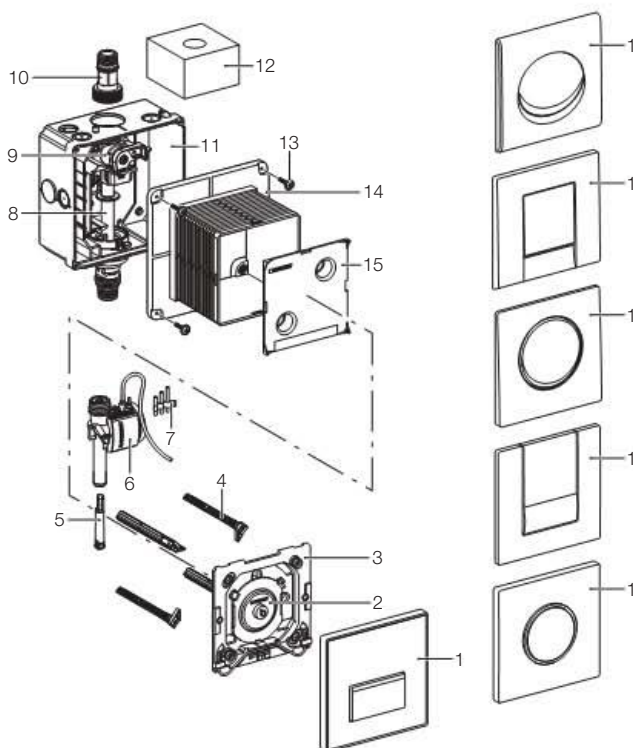

- 1 Plaque de déclenchement
- 2 Poussoir pneumatique
- 3 Cadre de fixation
- 4 Boulons d'écartement
- 5 Limiteur de débit
- 6 Vanne pneumatique
- 7 Jeu de buses
- 8 Fourreau
- 9 Robinet d'arrêt avec étranglement
- 10 Mamelon de raccordement
- 11 Boîtier à encastrer
- 12 Eponge de protection
- 13 Vis de fixation
- 14 Boîtier de réservation
- 15 Plaque de protection

Maintenance

Intervalle d'entretien

Effectuer les travaux de maintenance suivants en cas de nécessité et au plus tard dans les intervalles indiqués :

- Nettoyer la surface de la plaque de déclenchement - toutes les semaines par l'exploitant
- Nettoyer le filtre panier - tous les 2 ans, par une personne qualifiée

Travaux de maintenance

Nettoyer la plaque de déclenchement



ATTENTION

Les produits de nettoyage agressifs et abrasifs peuvent endommager la surface.

- ▶ Ne pas utiliser de détergent agressif à base de chlore ou d'acide ou qui soit abrasif ou corrosif, mais uniquement des produits de nettoyage doux et de l'eau



Nous ne pouvons être tenus responsables en cas de réclamations survenues après une utilisation inappropriée de produits de nettoyage.

Nettoyer le filtre panier ou le remplacer



Entretien

Recherche d'erreurs

Problème	Cause possible	Remèdes
L'eau ne coule pas	L'arrivée d'eau est coupée	Ouvrir l'arrivée d'eau
	Le filtre panier est bouché ou encrassé	Nettoyer le filtre panier ou le remplacer • Voir « Maintenance, Nettoyer ou remplacer le filtre panier »
	Pas de pression dans le réseau d'eau	Contrôler la pression de l'eau • Rétablir la pression de l'eau
	Le raccordement à emboîter du tuyau à air entre le poussoir pneumatique et la vanne pneumatique est déconnecté	Rétablir le raccordement à emboîter du tuyau à air
	Le tuyau à air est plié ou coupé	Remplacer le tuyau à air défectueux
Ecoulement continu (l'eau ne s'arrête pas)	La vanne pneumatique est défectueuse	Remplacer la vanne pneumatique • Voir « Entretien, Remplacer la vanne pneumatique »
	La vanne pneumatique est défectueuse	Remplacer la vanne pneumatique • Voir « Entretien, Remplacer la vanne pneumatique »
La céramique d'urinoir n'est pas suffisamment rincée	L'étranglement n'est pas assez ouvert	Ouvrir l'étranglement
De l'eau de rinçage gicle de la céramique d'urinoir	Débit trop important	Monter un limiteur de débit • Le limiteur de débit est disponible en accessoire (242.484.00.1)

Travaux d'entretien

Ces instructions de service présentent la commande avec un guide d'eau vertical (A). La commande avec guide d'eau horizontal (B) n'est pas présentée ; les travaux de maintenance sont toutefois identiques.

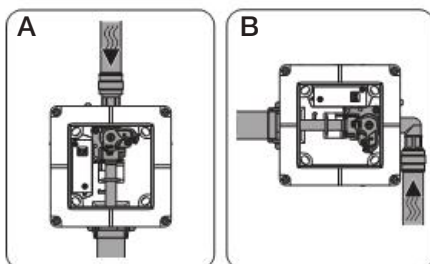

Les travaux d'entretien suivants sont décrits dans ces instructions :

- Démontez la plaque de déclenchement et le cadre de fixation
- Remplacez la vanne pneumatique
- Remplacez la vis d'étranglement
- Remplacez le joint à lèvres de la conduite de rinçage
- Montez le cadre de fixation et la plaque de déclenchement

Démonter la plaque de déclenchement et du cadre de fixation

1

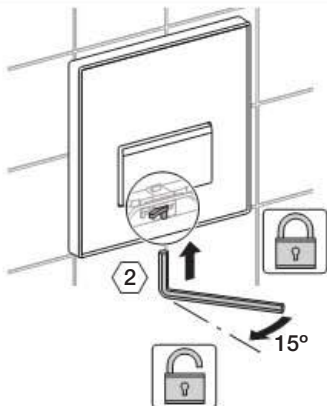

2

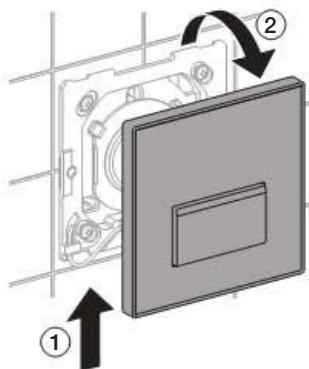

3

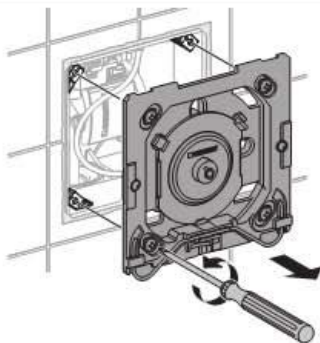

4

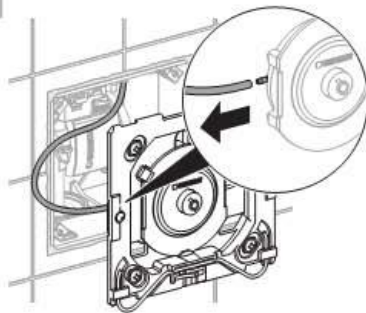

FR

Remplacer la vanne pneumatique

Conditions requises

La plaque de déclenchement et le cadre de fixation sont démontés.

Voir « Entretien, Démontez la plaque de déclenchement et le cadre de fixation ».

1

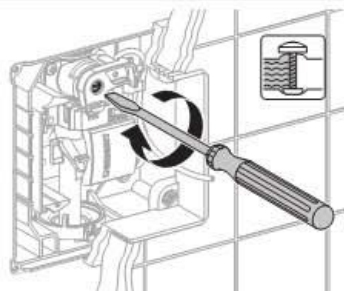

2

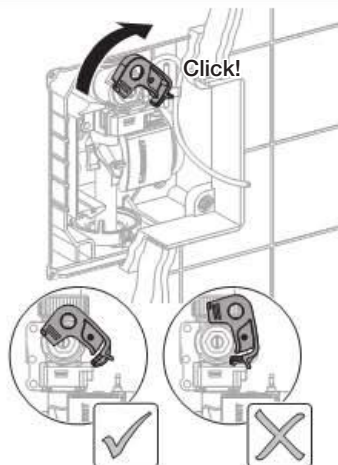

Entretien

3

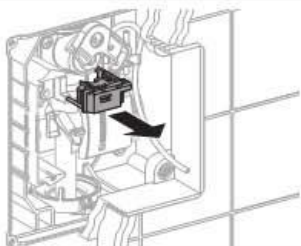

4

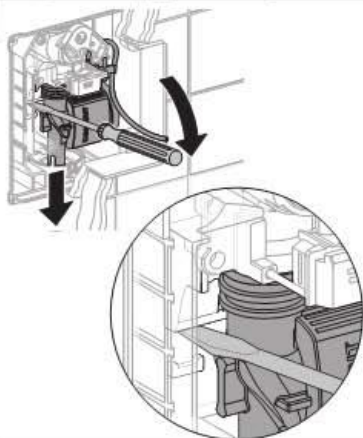

5

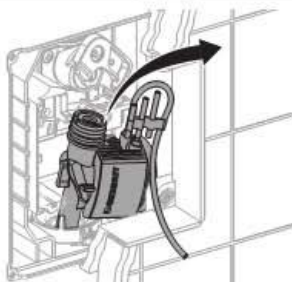

6

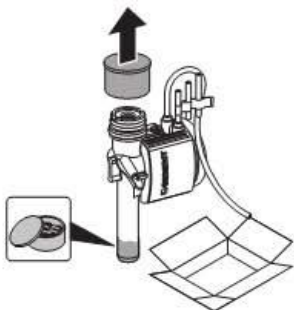

7

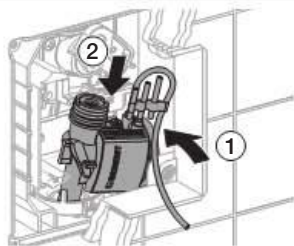

8

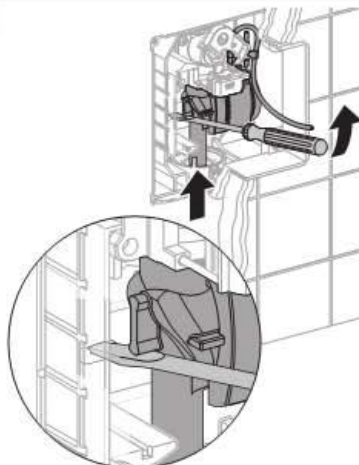

9

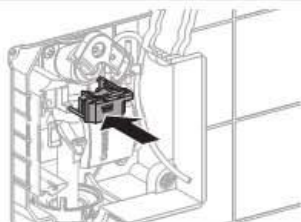

10

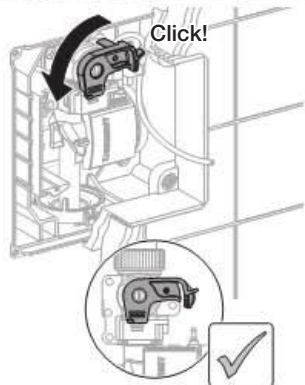

Remplacer la vis d'étrangement

Conditions requises

La plaque de déclenchement et le cadre de fixation sont démontés.

Voir « Entretien, Démontez la plaque de déclenchement et le cadre de fixation ».

1

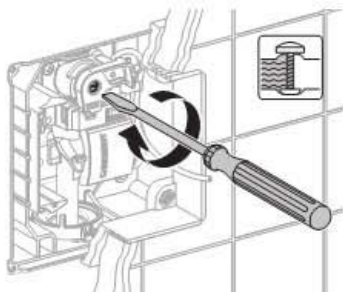

2 Couper l'arrivée d'eau générale.

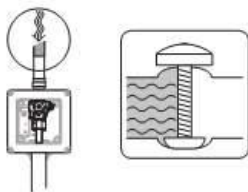

3

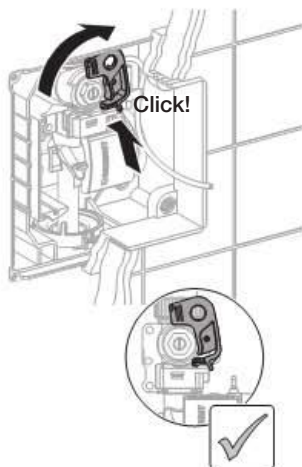

4



5

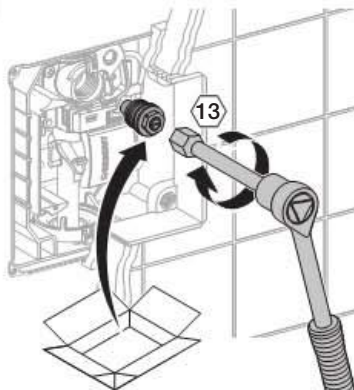

6

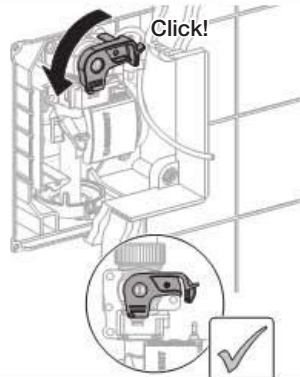

7

Ouvrir l'arrivée d'eau générale.



Remplacer le joint à lèvres de la conduite de rinçage

Conditions requises

La plaque de déclenchement et le cadre de fixation sont démontés.

Voir « Entretien, Démontez la plaque de déclenchement et le cadre de fixation ».

1

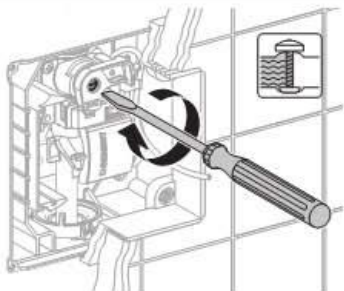

2

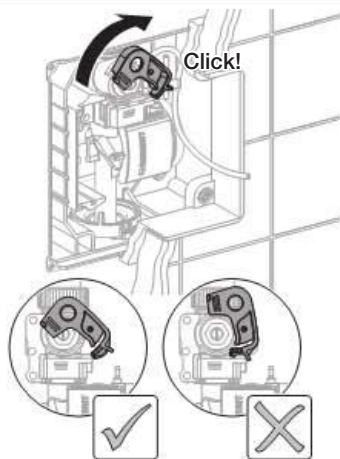

3

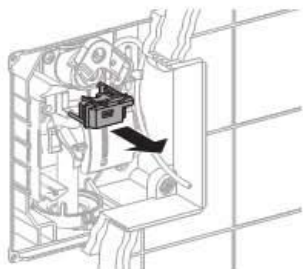

4

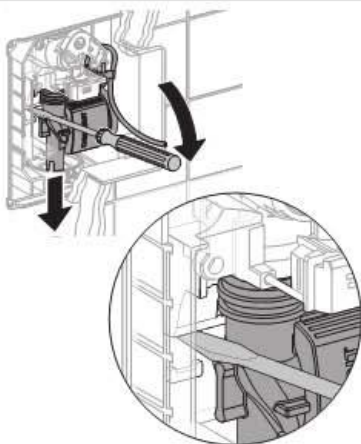

5

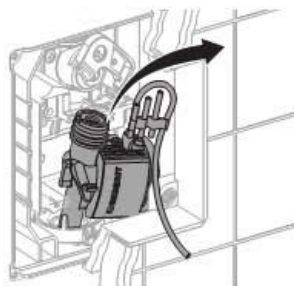

6

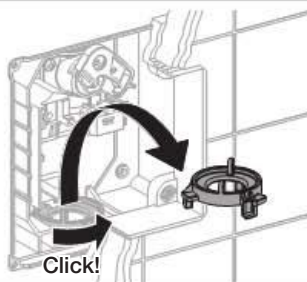

7

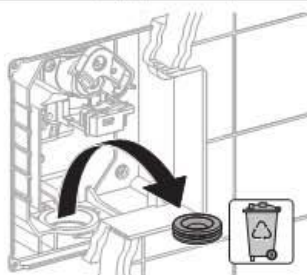

8



9

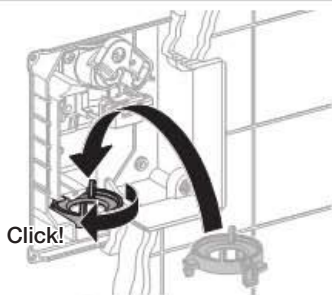

10

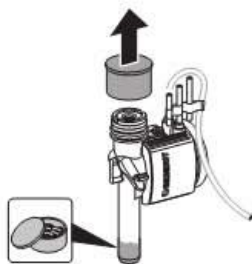

11

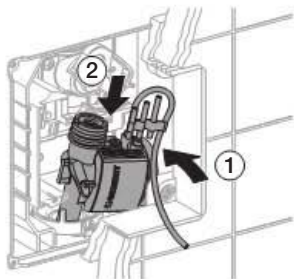

12

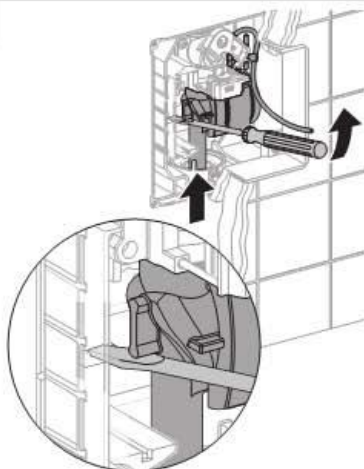

FR

13

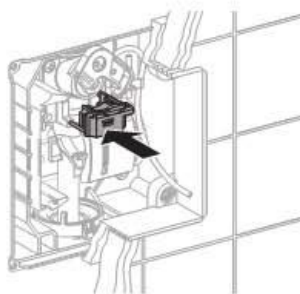

14

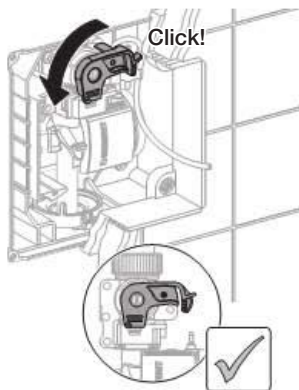

Monter le cadre de fixation et la plaque de déclenchement

1

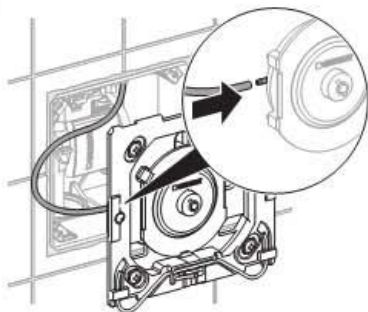

2

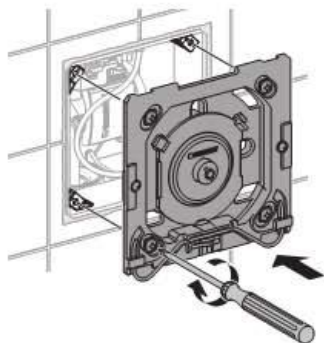

3

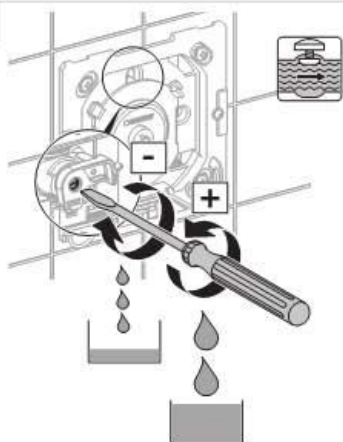

4

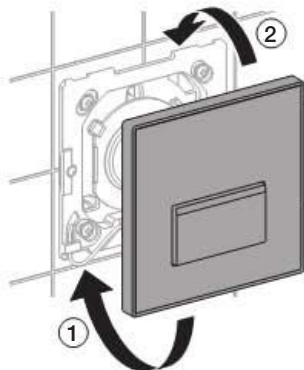

5

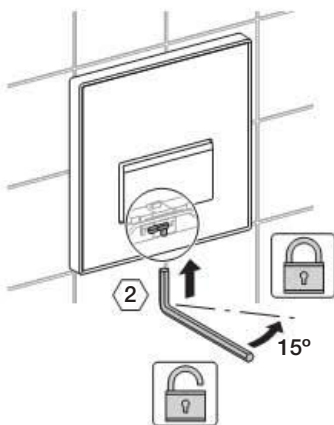

Caractéristiques techniques

Système pneumatique de la commande d'urinoir HyTouch

Débit d'eau à 1 bar	0,3 / 0,24 (avec limiteur de débit)	l/s
Test de pression de l'eau		16 bar
Test de pression de l'air / du gaz inerte		3 bar
Force de déclenchement		< 12 N
Temps de rinçage plage de réglage		4 / 8 / 12 s
Humidité		< 100 % relative
Plage de pression de fonctionnement		1 - 8 bars
Température d'utilisation de l'eau max.		30 °C

FR

Indicazioni generali

Note su queste istruzioni per l'uso

Conservare le istruzioni per l'uso e metterle a disposizione delle persone addestrate in caso di necessità.

Funzionamento, manutenzione

Gli interventi di manutenzione eseguibili dall'operatore sono esclusivamente quelli descritti nelle presenti istruzioni.

IT

Assistenza

Gli interventi di assistenza devono essere eseguiti esclusivamente da una persona addestrata. Un'errata esecuzione dei lavori, infatti, può causare sinistri, danni materiali e malfunzionamenti.





Gruppo target

I presente documento è destinato alle persone istruite secondo EN IEC 62079:2001.

Utilizzo conforme

I dispositivi di risciacquo per orinatoi HyTouch sono destinati al risciacquo della ceramica degli orinatoi. In caso di utilizzo diverso da quanto specificato, si esclude qualsiasi diritto di garanzia e responsabilità per danni alle persone e materiali.

Spiegazione simboli

Simbolo	Significato
 ATTENZIONE	Indica una possibile situazione di pericolo, che può causare danni fisici di leggera o media entità, oppure danni alle persone o materiali.
	Utilizzare grasso lubrificante!
	L'acqua della rete idrica è chiusa
	L'acqua della rete idrica è aperta

Contatto

In caso di dubbi o problemi, contattate la società di vendita Geberit del vostro Paese o visitate il sito www.geberit.com.

Struttura

Dispositivo pneumatico di risciacquo per orinatoi HyTouch

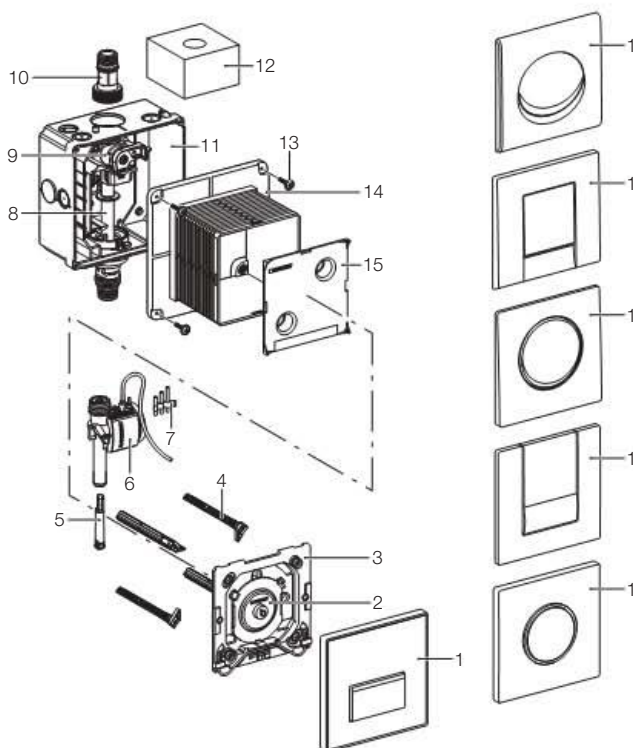

- 1 Placca di comando
- 2 Pulsante pneumatico
- 3 Telaio di fissaggio
- 4 Perno distanziatore
- 5 Limitatore di portata
- 6 Valvola pneumatica
- 7 Gruppo ugelli
- 8 Tubo vuoto
- 9 Rubinetto d'arresto con vite di regolazione
- 10 Nipplo d'allacciamento
- 11 Scatola da incasso
- 12 Spugna di protezione
- 13 Viti di fissaggio
- 14 Protezione cantiere
- 15 Coperchio protezione cantiere

Manutenzione

Intervallo di manutenzione

Effettuare i seguenti interventi di manutenzione secondo necessità, comunque non oltre gli intervalli di tempo indicati:

- pulizia della superficie della placca di comando - una volta alla settimana, a cura dell'operatore
- pulizia del filtro a cestello - ogni 2 anni, a cura di una persona addestrata

Interventi di manutenzione

Pulizia della placca di comando

ATTENZIONE
I detersivi aggressivi ed abrasivi possono danneggiare la superficie.

- ▶ Non impiegare prodotti abrasivi o caustici a base di cloro o acidi, ma soltanto detersivi delicati e acqua

i Non saranno riconosciuti reclami dovuti al trattamento improprio con detersivi.

Pulizia o sostituzione del filtro a cestello



Assistenza

Ricerca guasti

Problema	Possibile causa	Rimedio
L'acqua non scorre	L'alimentazione dell'acqua è chiusa	Aprire l'alimentazione dell'acqua
	Filtro a cestello intasato o sporco	Pulire o sostituire il filtro a cestello • Vedi "Manutenzione, pulire o sostituire il filtro a cestello"
	Nessuna pressione sull'impianto idrico	Controllare la pressione dell'acqua • Ripristinare la pressione dell'acqua
	Collegamento a spina del tubo flessibile pneumatico staccato tra pulsante e valvola	Ripristinare il collegamento a spina del tubo flessibile pneumatico
	Tubo flessibile pneumatico piegato o spezzato	Sostituire il tubo flessibile pneumatico difettoso
Flusso continuo (l'acqua non si ferma)	Valvola pneumatica difettosa	Sostituire la valvola pneumatica • Vedi "Assistenza, sostituire la valvola pneumatica"
	L'apertura della vite d'arresto è insufficiente	Aprire la vite d'arresto
La ceramica orinatoï non viene sufficientemente risciacquata	L'apertura della vite d'arresto è insufficiente	Aprire la vite d'arresto
L'acqua di risciacquo spruzza dalla ceramica orinatoï	Portata troppo elevata	Montare il limitatore di flusso • Il limitatore di flusso è disponibile come accessorio (242.484.00.1)

Interventi di assistenza

Il presente manuale di servizio mostra il dispositivo con alimentazione verticale dell'acqua (A) Il dispositivo con alimentazione orizzontale dell'acqua (B) non è illustrato, ma gli interventi di assistenza sono gli stessi.

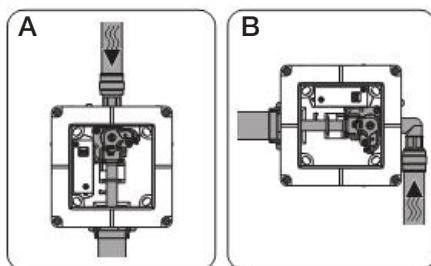

In questo capitolo sono descritti i seguenti interventi di assistenza:

- Smontare la placca di comando e il telaio di fissaggio
- Sostituire la valvola pneumatica
- Sostituire la vite di regolazione
- Sostituire la guarnizione a labbro del tubo di risciacquo
- Montare il telaio di fissaggio e la placca di comando

Smontaggio della placca di copertura e il telaio di fissaggio

1

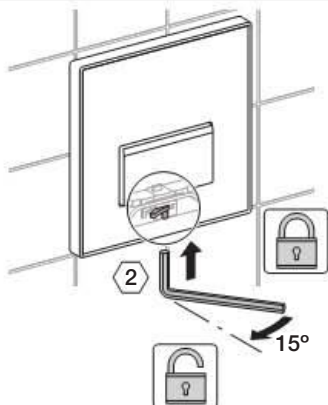

2

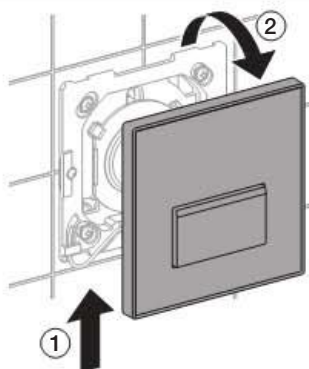

3

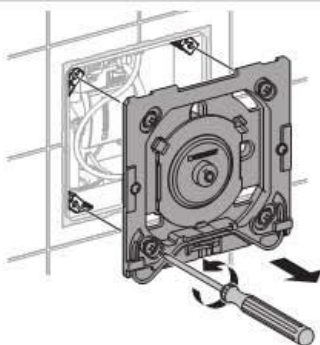

4

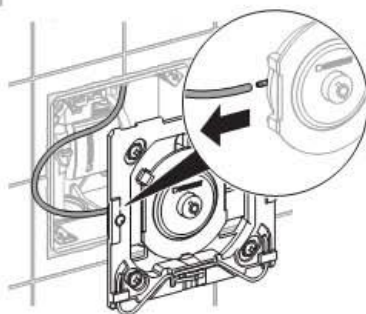

IT

Sostituzione della valvola pneumatica

Requisiti

La placca di comando e il telaio di fissaggio sono smontati.

Vedi "Assistenza, smontare la placca di comando e il telaio di fissaggio".

1

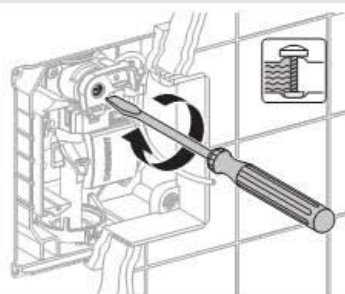

2

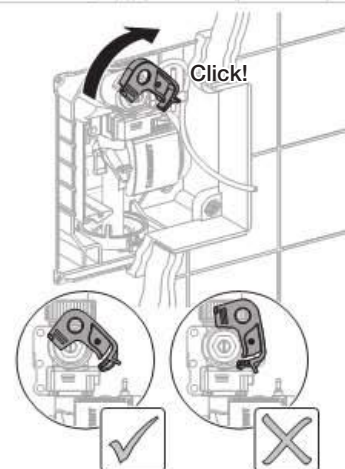

3

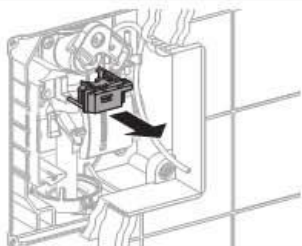

4

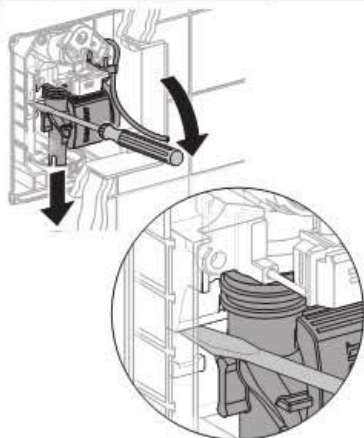

5

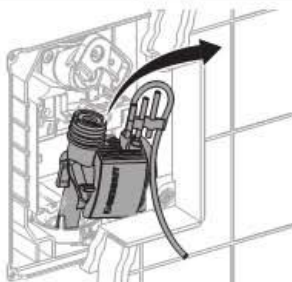

6

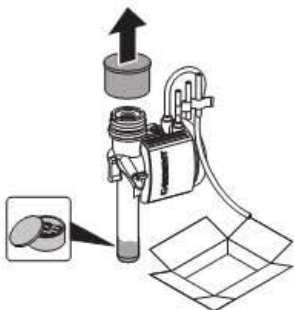

7

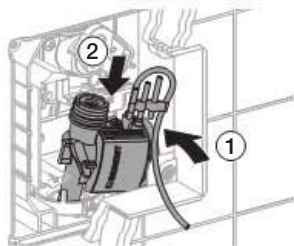

8

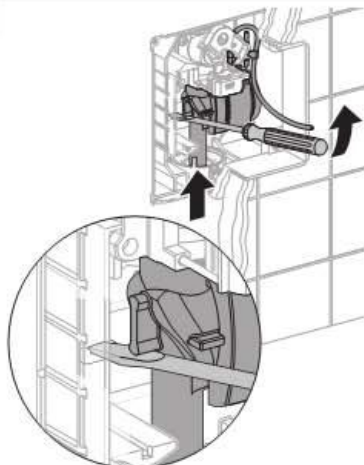

9

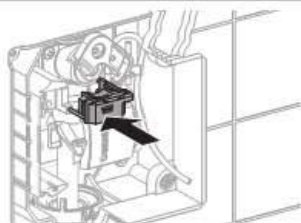

10

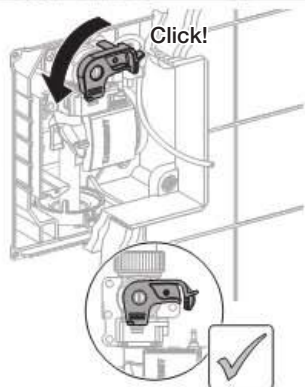

Sostituzione della vite di regolazione**Requisiti**

La placca di comando e il telaio di fissaggio sono smontati.

Vedi "Assistenza, smontare la placca di comando e il telaio di fissaggio".

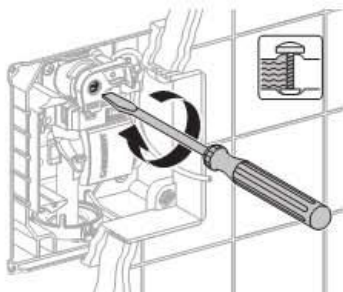
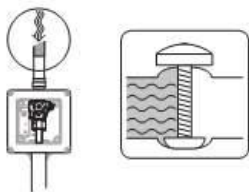
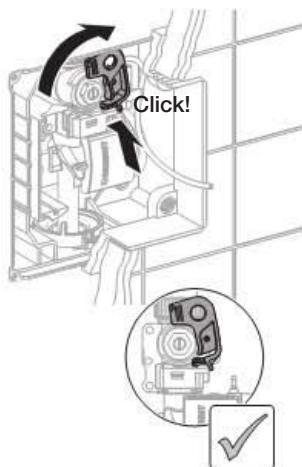
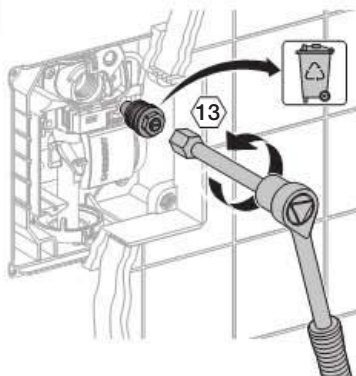
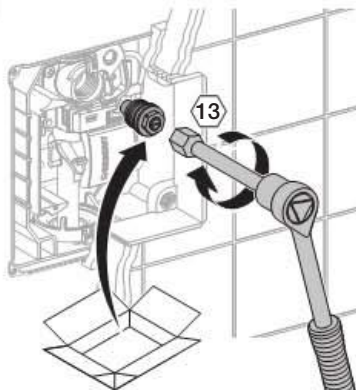
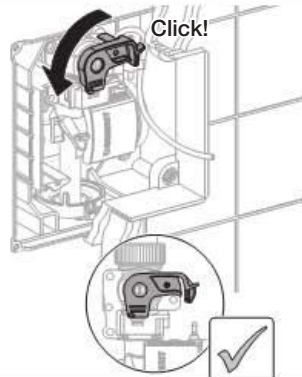
1**2** Chiedere l'alimentazione centrale dell'acqua.**3****4****5****6****7** Aprire l'alimentazione centrale dell'acqua.

Sostituzione della guarnizione a labbro del tubo di risciacquo

Requisiti

La placca di comando e il telaio di fissaggio sono smontati.

Vedi "Assistenza, smontare la placca di comando e il telaio di fissaggio".

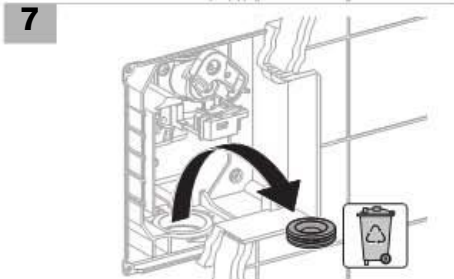
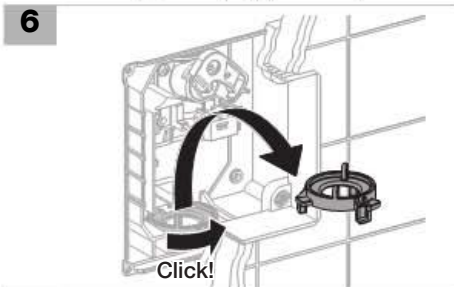
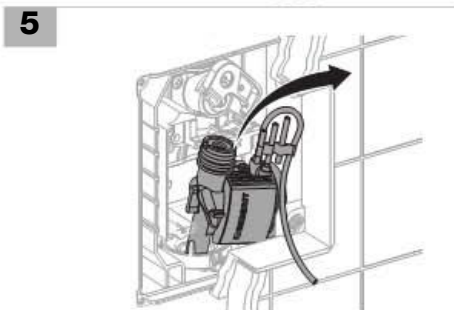
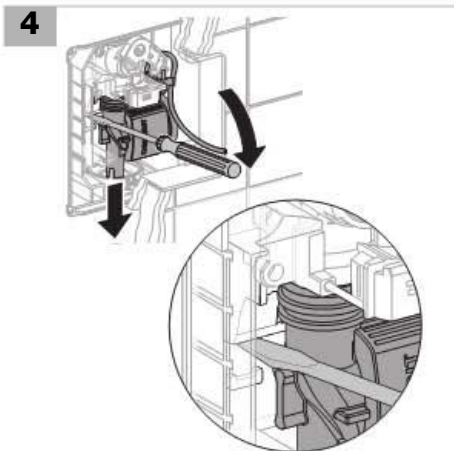
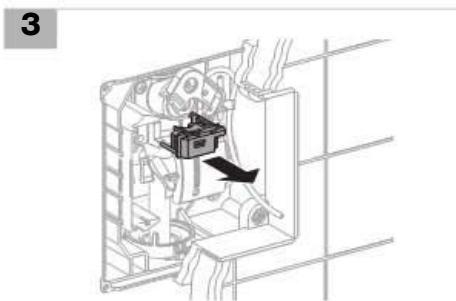
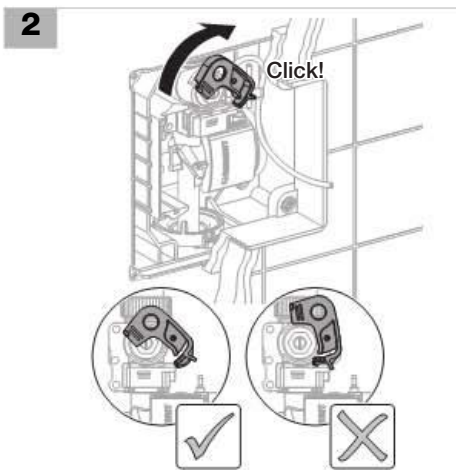
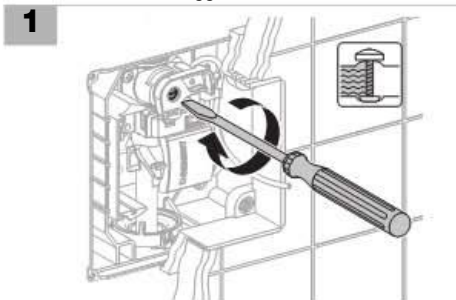

8



9

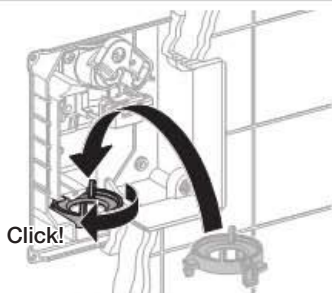

10

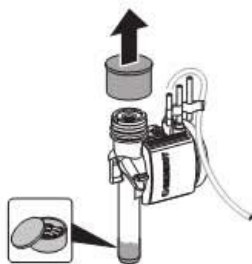

11

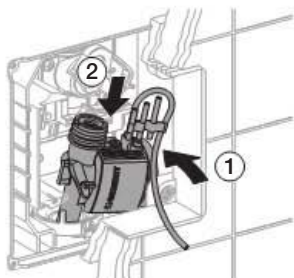

12

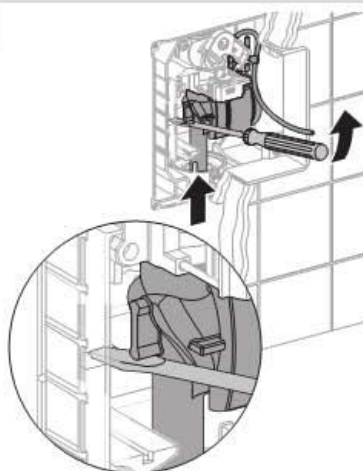

13

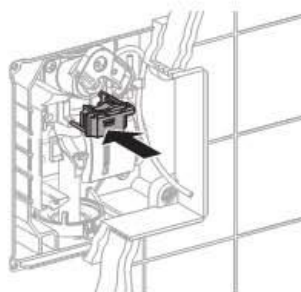

14

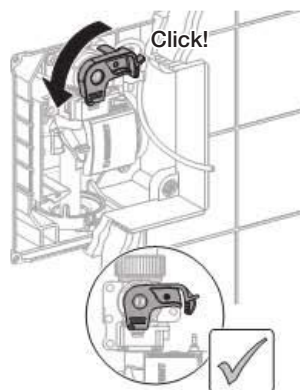

Montaggio del telaio di fissaggio e della placca di comando

1

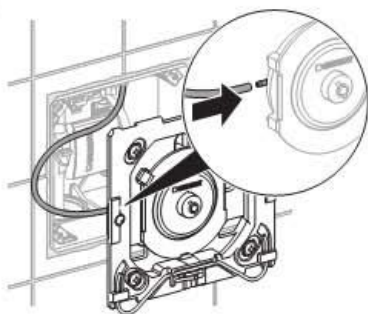

2

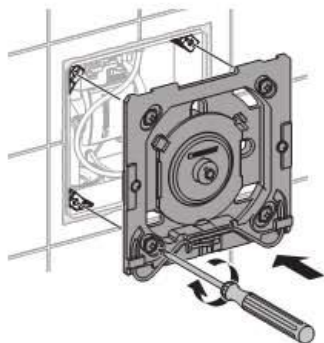

3

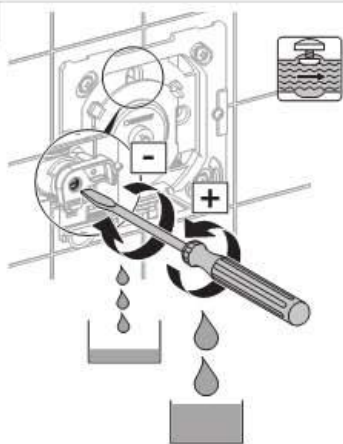

4

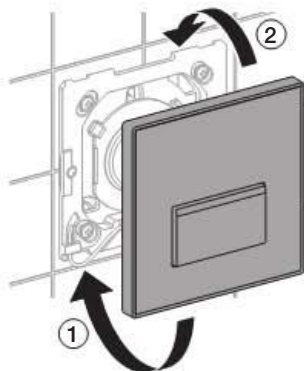

5

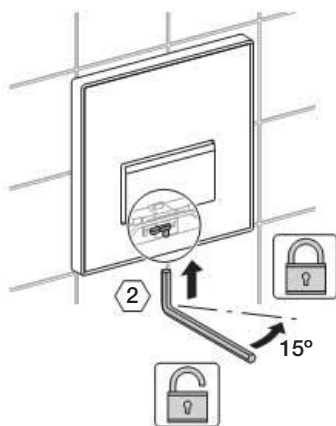

Dati tecnici

Dispositivo pneumatico di risciacquo per orinatoi HyTouch

Portata a 1 bar	0,3 / 0,24 (con limitatore di flusso) l/s
Pressione di prova acqua	16 bar
Pressione di prova aria / gas inerte	3 bar
Forza di azionamento	< 12 N
Campo di regolazione tempo di risciacquo	4 / 8 / 12 s
Umidità dell'aria	< 100 % relativa
Range di pressione durante il funzionamento	1 - 8 bar
Temperatura max. d'esercizio dell'acqua	30 °C

IT

Algemene informatie

Deze handleiding

Bewaar de handleiding en stel deze indien nodig aan een technisch expert ter beschikking.

Gebruik, onderhoud

Onderhoudswerkzaamheden mogen door de beheerder alleen worden uitgevoerd voor zover ze in deze handleiding worden beschreven.

Service

Servicewerkzaamheden mogen alleen door een technisch expert worden uitgevoerd. Verkeerd uitgevoerde werkzaamheden kunnen tot ongevallen, materiële schade en storingen leiden.





Doelgroep

Dit document is bestemd voor technische experts conform EN IEC 62079:2001.

Reglementair gebruik

De HyTouch urinoir stuursystemen zijn bedoeld voor het spoelen van urinoirs. Bij gebruik voor een ander doel kan Geberit bij letsel of schade aan eigendom niet aansprakelijk gesteld worden.

Uitleg van symbolen

Symbol	Betekenis
	VOORZICHTIG Wijst op een mogelijke gevaarlijke situatie die licht tot matig letsel of schade aan eigendom tot gevolg kan hebben.
	Smeervet gebruiken!
	Leidingwater is uitgezet
	Leidingwater is aangezet

Contact

Neem bij vragen of problemen contact op met de verantwoordelijke Geberit verkoopmaatschappij of kijk op www.geberit.com.

Opbouw

HyTouch urinoir stuursysteem pneumatisch

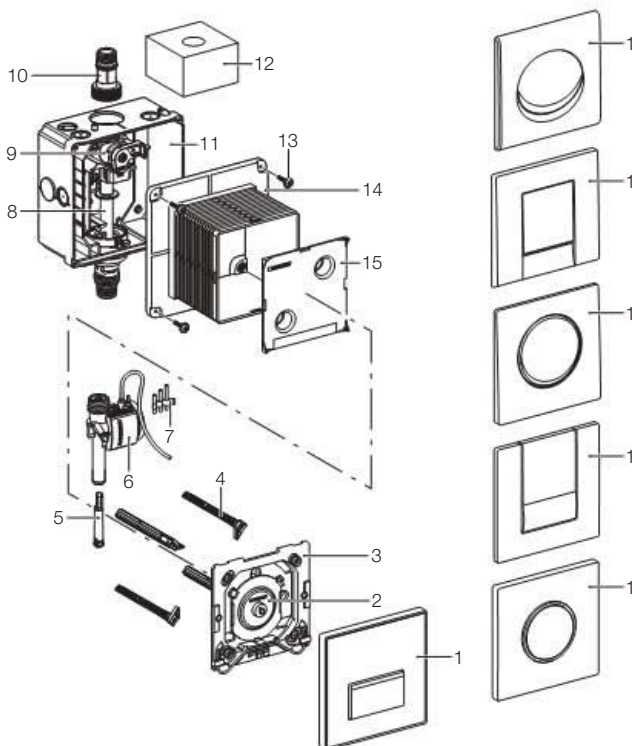

- 1 Bedieningsplaat
- 2 Pneumatische drukknop
- 3 Montageframe
- 4 Bevestigingsdraadstangen
- 5 Begrenzer van doorstroomvolume
- 6 Pneumatische ventiel
- 7 Set mondstukken
- 8 Lege buis
- 9 Afsluitventiel met regelklep
- 10 Aansluitnippel
- 11 Inbouwkast
- 12 Bescherm spons
- 13 Bevestigingsschroeven
- 14 Sporingkoker
- 15 Deksel sporingkoker

Onderhoud

Onderhoudsinterval

De volgende onderhoudswerkzaamheden uitvoeren wanneer dat nodig is, maar uiterlijk na de aangegeven intervallen:

- Oppervlak van de bedieningsplaat reinigen - wekelijks, door de beheerder
- Korffilter reinigen - om de 2 jaar door een technisch expert

Onderhoudswerkzaamheden

Bedieningsplaat reinigen



VOORZICHTIG

Agressieve en schurende reinigingsmiddelen kunnen het oppervlak beschadigen.

- ▶ Gebruik geen chloorhoudende, zuurhoudende, schurende of bijtende reinigingsmiddelen, maar alleen milde reinigingsmiddelen en water



Klachten die door onjuiste behandeling met schoonmaakmiddelen zijn veroorzaakt, kunnen niet worden aanvaard.

Korffilter reinigen of vervangen



Service

Foutopsporing

Probleem	Mogelijke oorzaak	Verhelpen
Water stroomt niet	Watertoevoer is dicht	Watertoevoer openen
	Korffilter is verstopt of vuil	Korffilter reinigen of vervangen • Zie "Onderhoud, Korffilter reinigen of vervangen"
	Geen druk op het waterleidingnet	Waterdruk controleren • Voor waterdruk zorgen
	Pneumatische slang: steekverbinding tussen pneumatische drukknop en pneumatisch ventiel is verbroken	Pneumatische slang: voor steekverbinding zorgen
	Pneumatische slang is geknikt of gebroken	Defecte pneumatische slang vervangen
Doorloper (water stopt niet)	Pneumatisch ventiel is defect	Pneumatisch ventiel vervangen • Zie "Service, Pneumatisch ventiel vervangen"
	Regelklep is te weinig geopend	Regelklep openen
Urinoir wordt onvoldoende uitgespoeld	Te groot doorstroomvolume	Begrenzer van doorstroomvolume monteren • Begrenzer van doorstroomvolume is als toebehoren verkrijgbaar (242.484.00.1)

Servicewerkzaamheden

In deze servicehandleiding is de sturing met verticale watertoevoer (A) te zien. De sturing met horizontale watertoevoer (B) wordt niet getoond, maar de servicewerkzaamheden zijn gelijk.

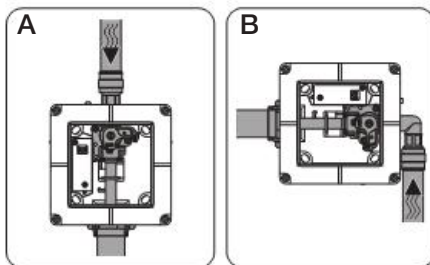

De volgende servicewerkzaamheden worden hier beschreven:

- Bedieningsplaat en montageframe demonteren
- Pneumatisch ventiel vervangen
- Regelschroef vervangen
- Lipafdichting spoelleiding vervangen
- Montageframe en bedieningsplaat monteren

Bedieningsplaat en montageframe demonteren

1

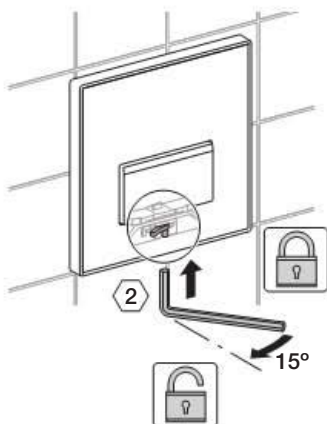

2

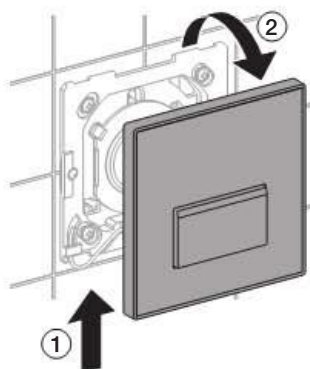

3

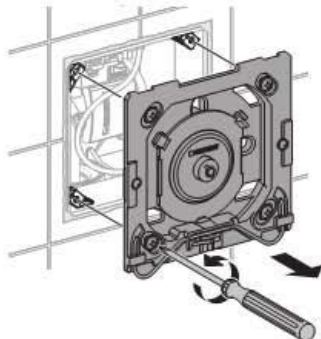

4

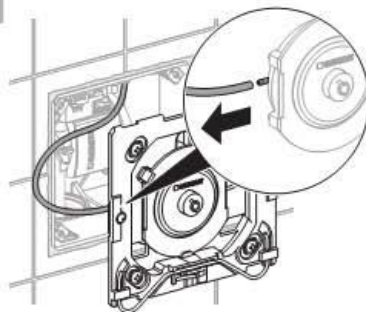

NL

Pneumatisch ventiel vervangen

Voorwaarden

Bedieningsplaat en montageframe zijn gedemonteerd.

Zie "Service, Bedieningsplaat en montageframe demonteren".

1

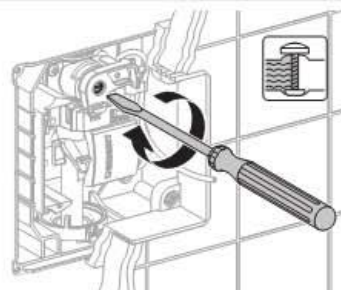

2

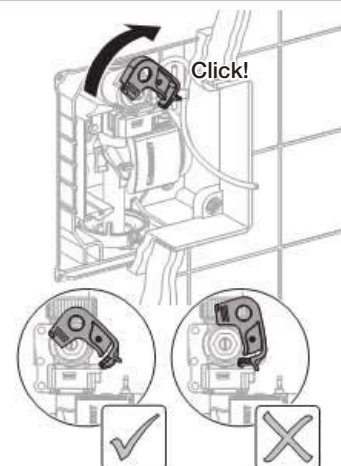

3

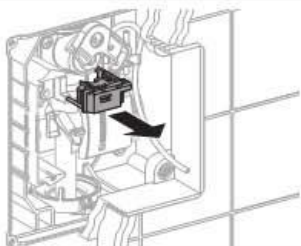

4

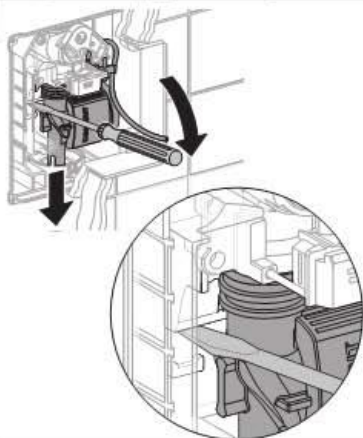

5

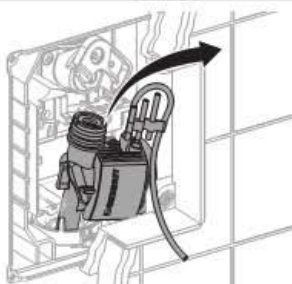

6

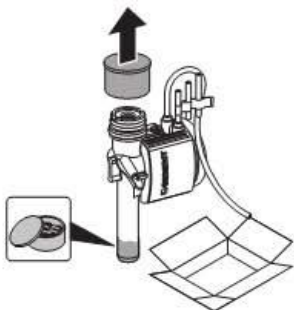

7

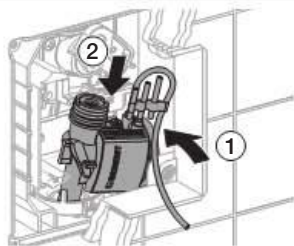

8

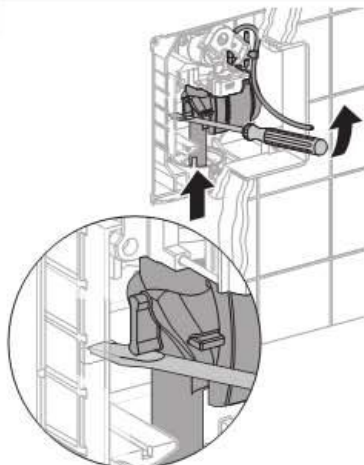

9

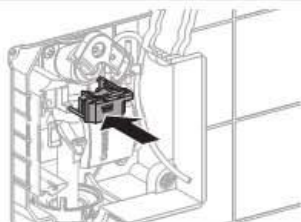

10

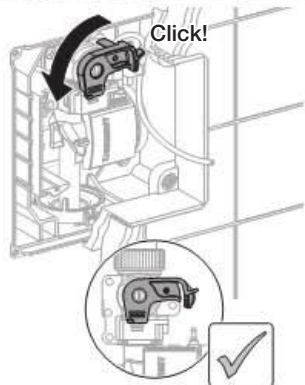

Regelschroef vervangen

Voorwaarden

Bedieningsplaat en montageframe zijn gedomonteerd.

Zie "Service, Bedieningsplaat en montageframe demonteren".

1

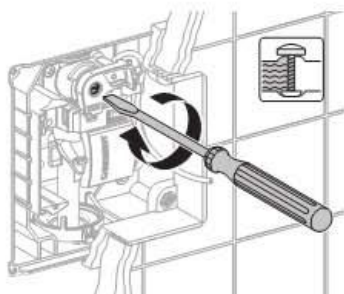

2 Centrale watertoevoer sluiten.

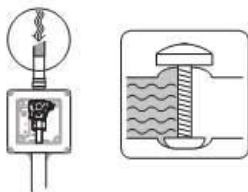

3

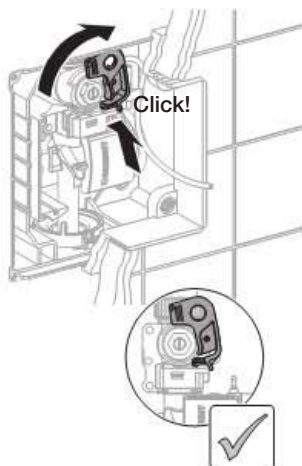

4

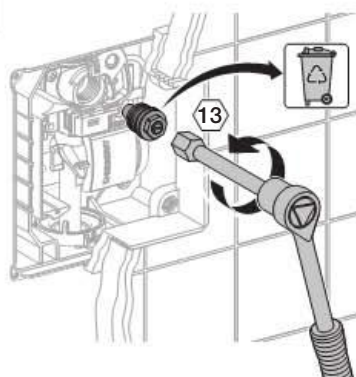

5

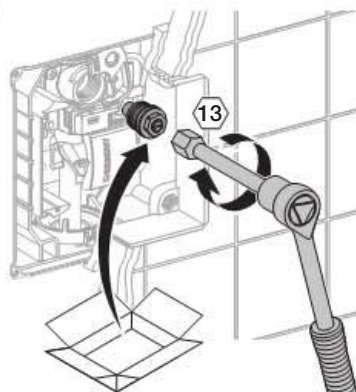

6

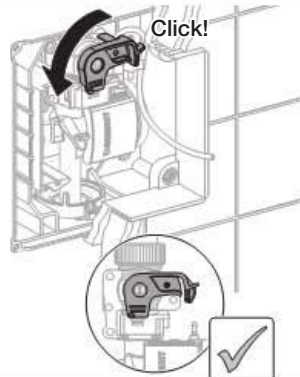

7 Centrale watertoevoer openen.



Lipafdichting spoelleiding vervangen

Voorwaarden

Bedieningsplaat en montageframe zijn gedemonteerd.

Zie "Service, Bedieningsplaat en montageframe demonteren".

1

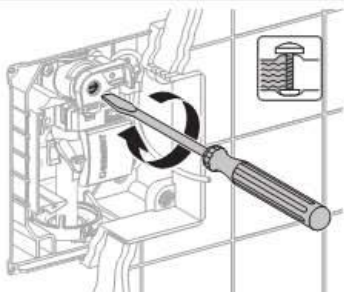

2

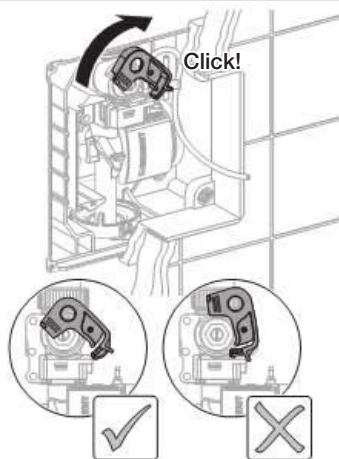

3

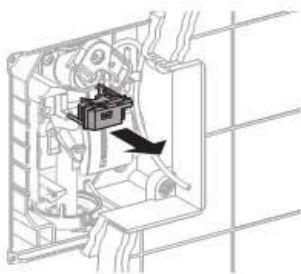

4

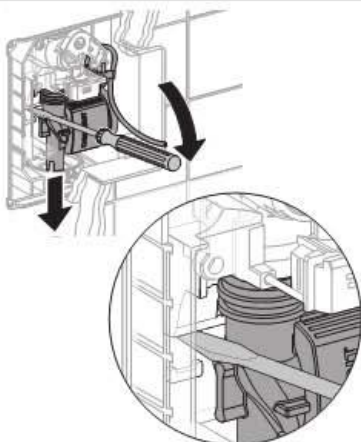

5

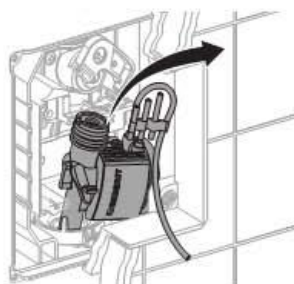

6

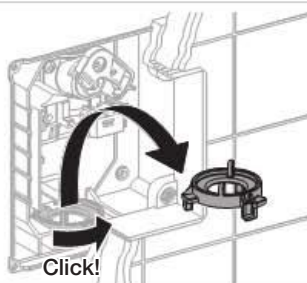

7

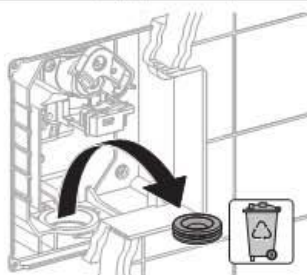

8



9

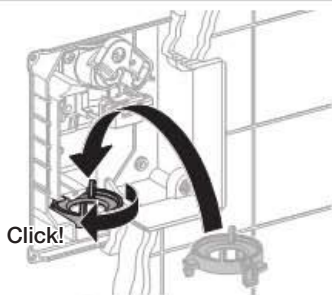

10

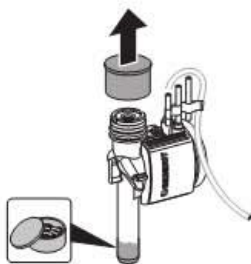

11

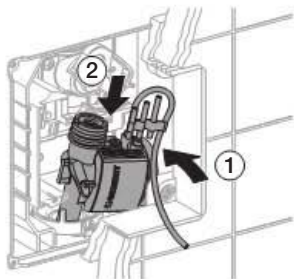

12

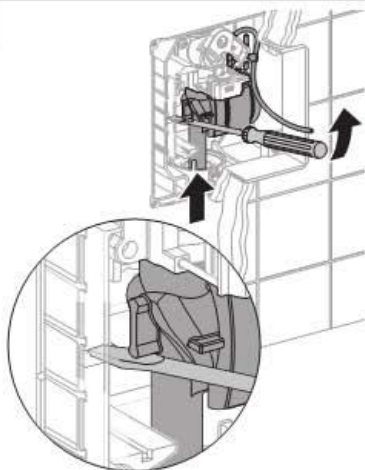

NL

13

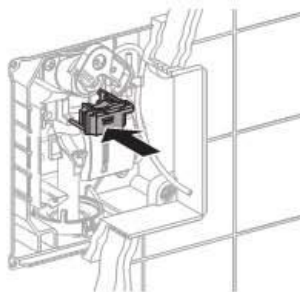

14

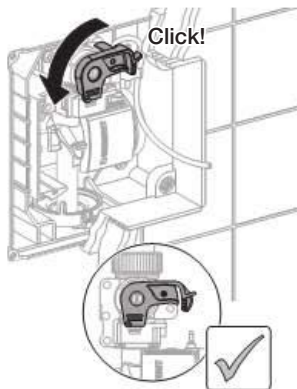

Montageframe en bedieningsplaat
monteren

1

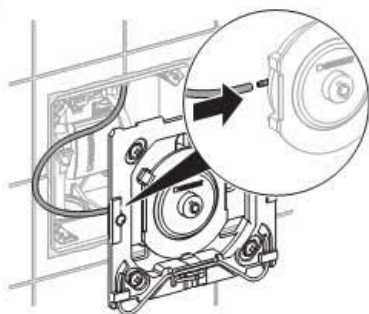

2

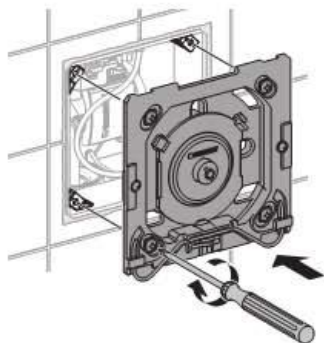

3

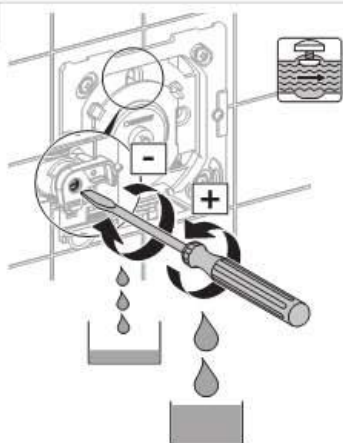

4

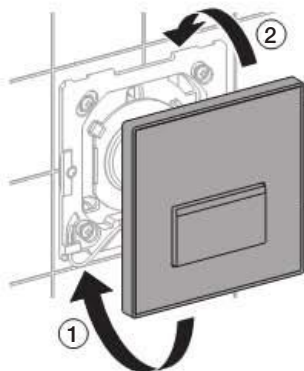

5

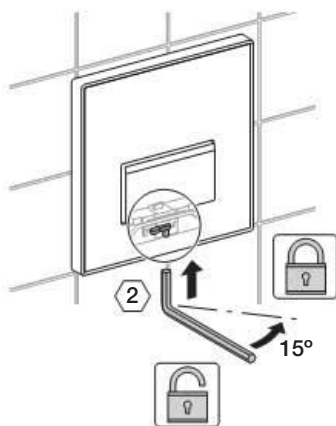

Technische gegevens

HyTouch urinoir stuursysteem pneumatisch

Doorstroomvolume bij 1 bar	0,3 / 0,24 (met begrenzer van doorstroomvolume)	l/s
Proefdruk water		16 bar
Proefdruk lucht / inert gas		3 bar
Activeringskracht		< 12 N
Instelbereik spoeltijd	4 / 8 / 12	s
Luchtvochtigheid		< 100 % relatief
Drukbereik in bedrijf		1 - 8 bar
Max. bedrijfstemperatuur water		30 °C

NL

Información general

Las presentes instrucciones de servicio

Deben guardarse las instrucciones de servicio y, si fuera preciso, facilitarlas al técnico especializado que corresponda.

Funcionamiento, mantenimiento

Los trabajos de mantenimiento sólo pueden ser realizados por el propietario en la medida que estén descritos en las presentes instrucciones.

Servicio técnico

Los trabajos de reparación sólo pueden ser realizados por un técnico especializado. Unos trabajos incorrectos pueden causar accidentes, daños materiales y un mal funcionamiento.





Grupo objetivo

Este documento está dirigido a personas cualificadas conforme EN EC 62079:2001.

Aplicación adecuada

Los sistemas de descarga de urinarios HyTouch están destinados al lavado de los urinarios cerámicos. En el caso de un uso para fines inadecuados se excluye cualquier garantía y responsabilidad en caso de daños personales y materiales.

Significado de los símbolos

Símbolo	Significado
	ATENCIÓN Indica una posible situación peligrosa que puede tener como consecuencia lesiones corporales o daños materiales leves o medios.
	¡Utilizar grasa lubricante!
	El agua de abastecimiento está cerrada
	El agua de abastecimiento está abierta

Contacto

En caso de dudas o problemas, póngase en contacto con la empresa distribuidora competente de Geberit, o consulte www.geberit.com.

Descripción del sistema

Sistema neumático para sistema de descarga de urinarios HyTouch

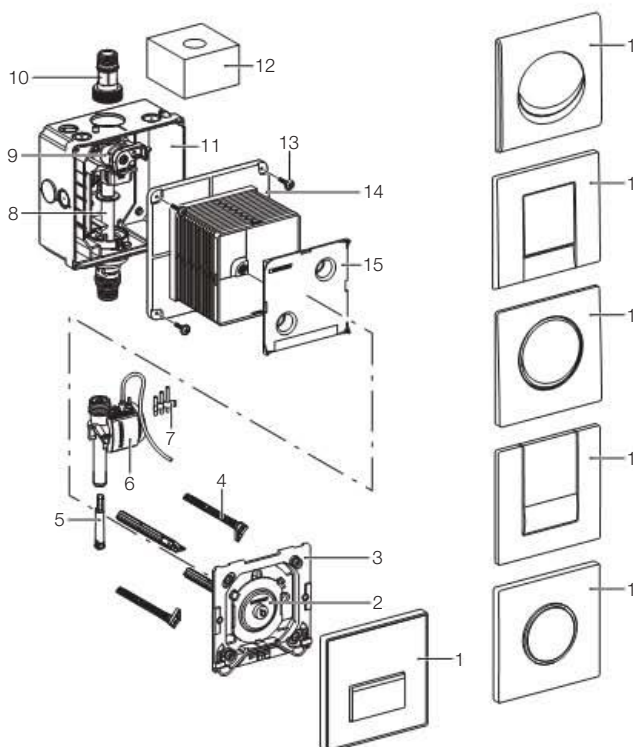

- 1 Pulsador
- 2 Pulsador neumático
- 3 Marco de fijación
- 4 Patas fijación marco
- 5 Limitador de flujo
- 6 Válvula neumática
- 7 Juego de boquillas
- 8 Tubo de protección
- 9 Llave de paso con regulador
- 10 Conexión suministro
- 11 Carcasa
- 12 Esponja protectora
- 13 Tornillos de fijación
- 14 Cajetín premontaje
- 15 Tapa de protección

Mantenimiento

Intervalo de mantenimiento

Realizar los siguientes trabajos de mantenimiento cuando sea necesario; pero, como muy tarde, en los intervalos indicados:

- Limpiar la superficie del pulsador: semanalmente, por parte del propietario
- Limpiar el filtro de cesta: cada dos años, por parte de una persona cualificada

Trabajos de mantenimiento

Limpiar el pulsador

ATENCIÓN
Unos productos de limpieza agresivos y abrasivos pueden dañar la superficie.

- ▶ No utilice productos de limpieza que contengan cloro o ácido ni sustancias abrasivas o cáusticas, sino únicamente productos de limpieza suaves y agua.

i No se aceptan reclamaciones que se deban a un tratamiento inadecuado con productos de limpieza.

Limpiar o sustituir el filtro de cesta



Servicio técnico

Búsqueda de errores

Problema	Posible causa	Remedio
El agua no sale	La llave de paso está cerrada	Abrir la llave de paso
	El filtro de cesta está obstruido o sucio	Limpiar o sustituir el filtro de cesta • Ver "Mantenimiento, limpiar o sustituir el filtro de cesta"
	No hay presión en la red de abastecimiento	Comprobar la presión de agua • Restablezca la presión de agua
	La conexión enchufable del conducto neumático entre el pulsador neumático y la válvula neumática está separada	Establecer la conexión enchufable del conducto neumático
	El conducto neumático está doblado o roto	Sustituir el conducto neumático defectuoso
Flujo ininterrumpido (el agua no se para)	La válvula neumática está defectuosa	Sustituir la válvula neumática • Véase "Servicio técnico, sustituir la válvula neumática"
	El regulador se ha abierto demasiado poco	Sustituir la válvula neumática • Véase "Servicio técnico, sustituir la válvula neumática"
El urinario cerámico se ha enjuagado de forma insuficiente	El regulador se ha abierto demasiado poco	Abrir regulador
Salen salpicaduras del agua de descarga del urinario cerámico	Caudal demasiado alto	Montar limitador de flujo • El limitador de flujo está disponible como accesorio (242.484.00.1)

Reparaciones

Estas instrucciones de servicio muestran el control con flujo de agua vertical (A). No se muestra el control con flujo de agua horizontal (B); pero las reparaciones son las mismas.

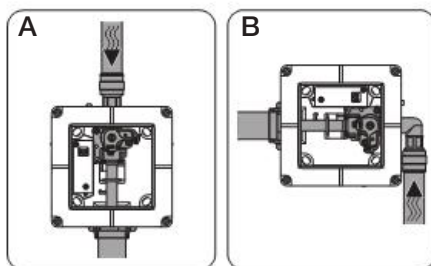

Aquí se describen las siguientes reparaciones:

- Desmontar el pulsador y el marco de fijación
- Sustituir la válvula neumática
- Sustituir el tornillo de corte
- Sustituir la junta labial de la conducción de descarga
- Montar el marco de fijación y el pulsador

Desmontar el pulsador y el marco de fijación

1

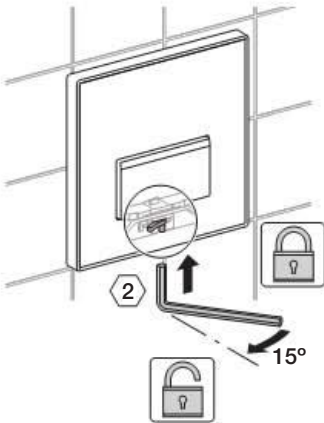

2

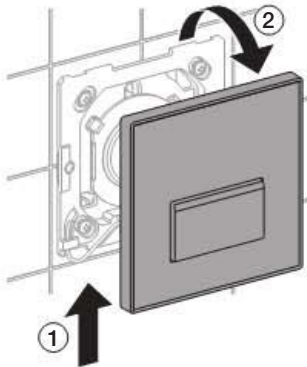

3

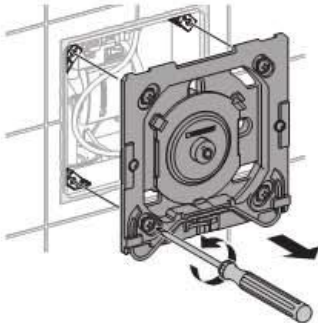

4

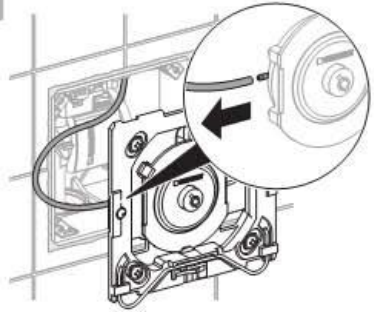

ES

Sustituir la válvula neumática

Prerequisitos

El pulsador y el marco de fijación están desmontados.

Ver "Servicio técnico, desmontar el pulsador y el marco de fijación".

1

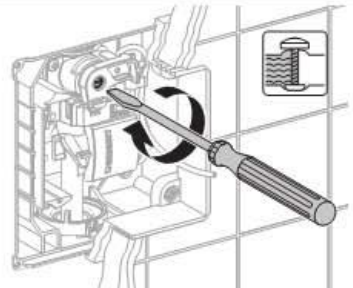

2

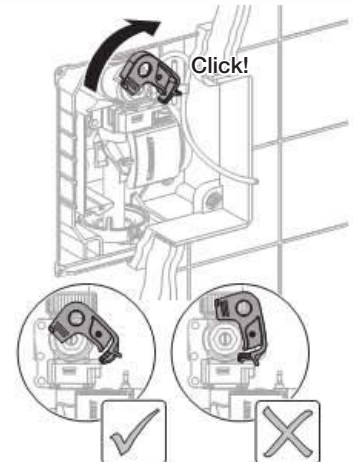

Servicio técnico

3

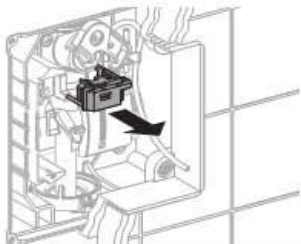

4

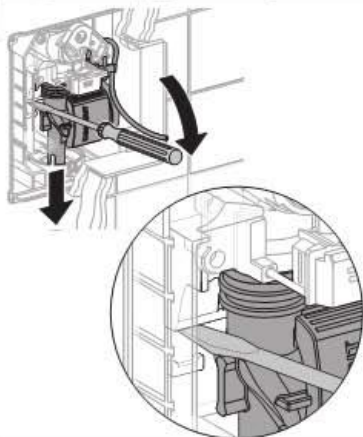

5

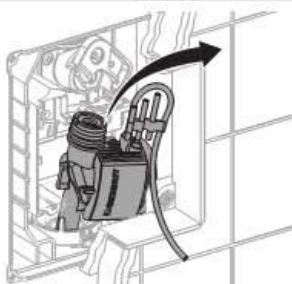

6

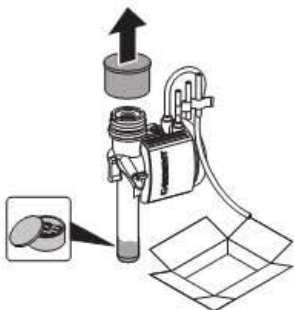

7

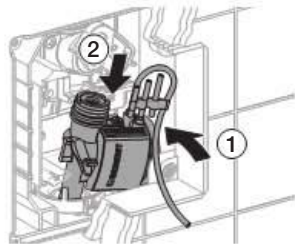

8

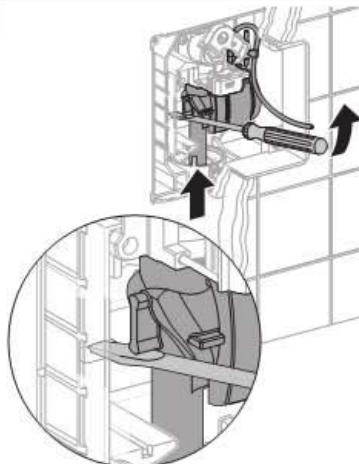

9

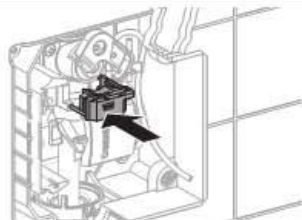

10

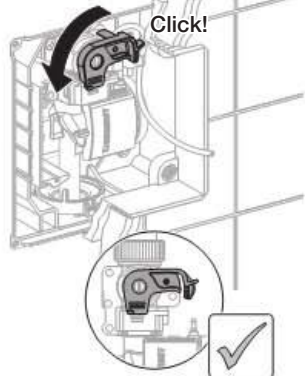

Sustituir el tornillo de corte

Prerequisitos

El pulsador y el marco de fijación están desmontados.

Ver "Servicio técnico, desmontar el pulsador y el marco de fijación".

1

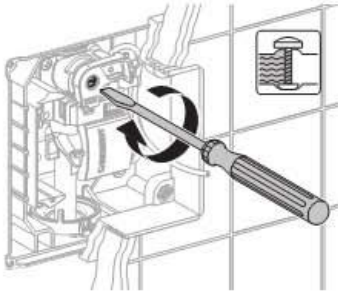

2 Cierre la llave de paso central.

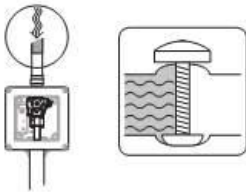

3

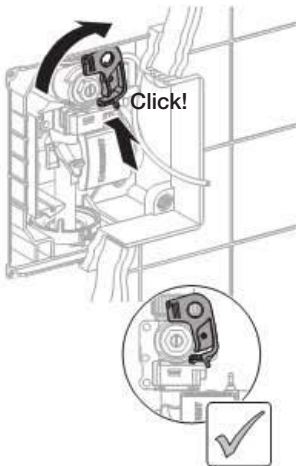

4

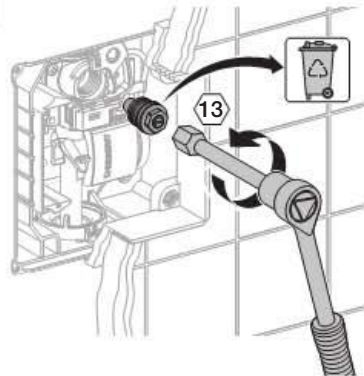

5

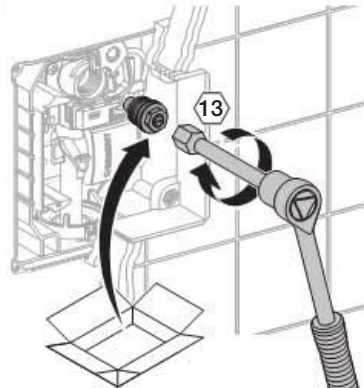

6

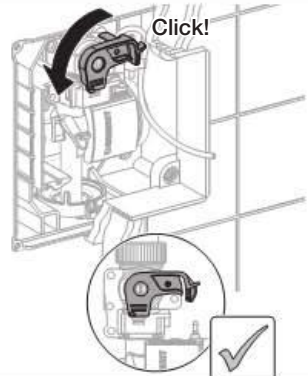

7 Abra la llave de paso central.



Sustituir la junta labial de la conducción de descarga

Prerequisitos

El pulsador y el marco de fijación están desmontados.

Ver "Servicio técnico, desmontar el pulsador y el marco de fijación".

1

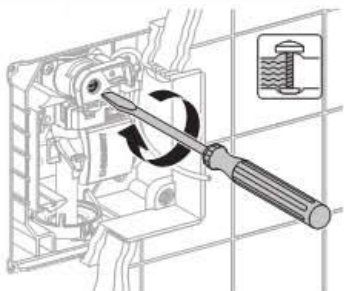

2

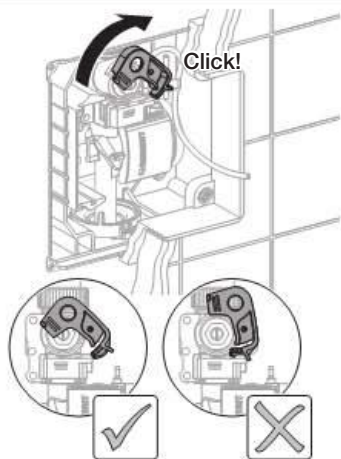

3

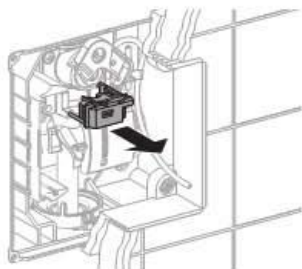

4

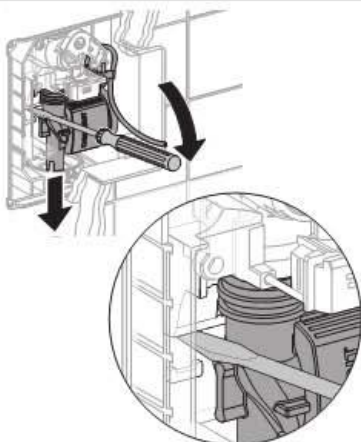

5

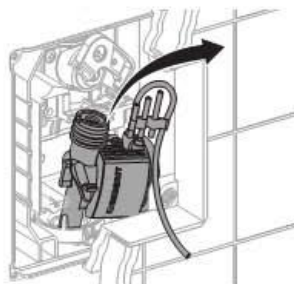

6

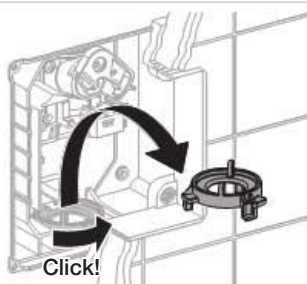

7

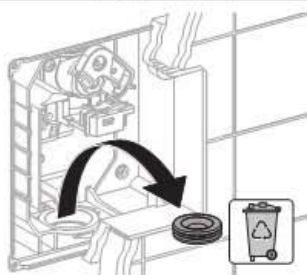

8



9

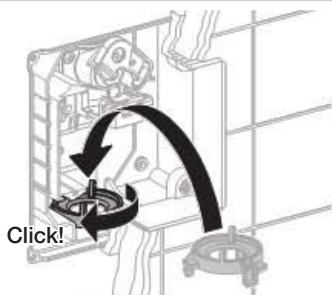

10

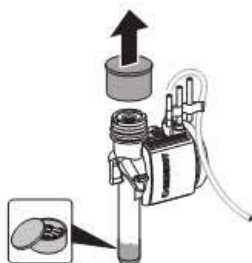

11

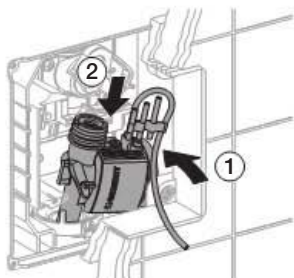

12

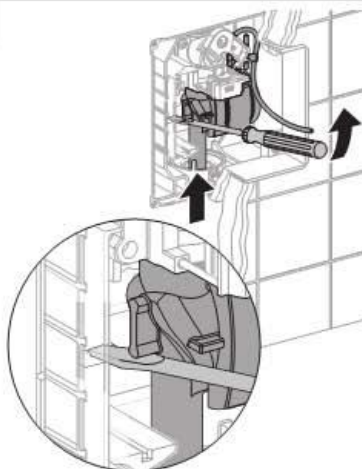

ES

13

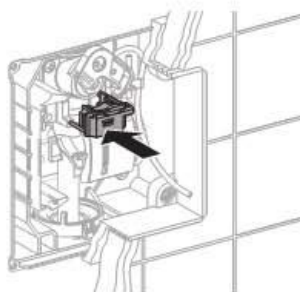

14

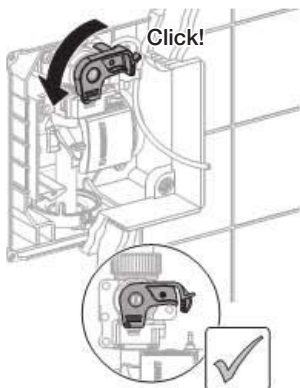

Montar el marco de fijación y el pulsador

1

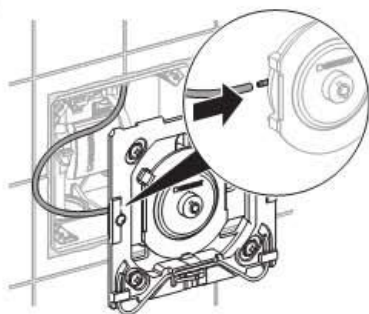

2

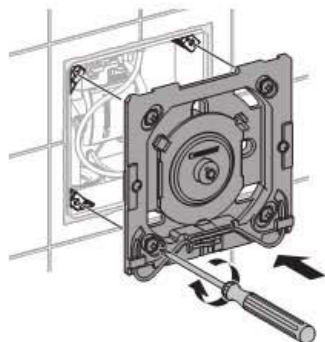

3

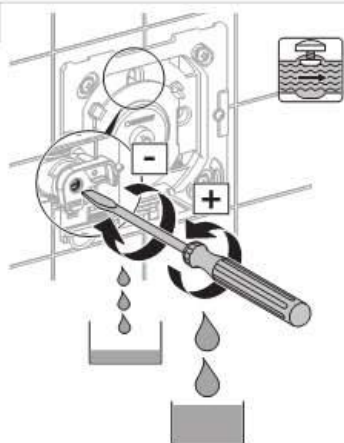

4

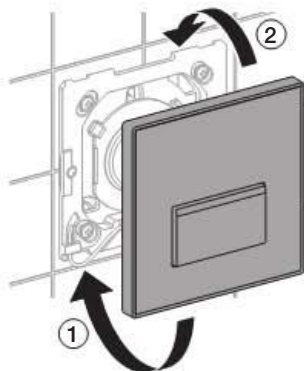

5

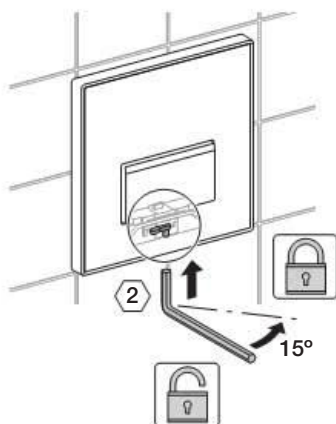

Información técnica

Sistema neumático para sistema de descarga de urinarios HyTouch

Caudal a 1 bar	0,3 / 0,24 (con limitador de flujo)	l/s
Presión de prueba del agua		16 bar
Presión de prueba del aire / gas inerte		3 bar
Fuerza de accionamiento		< 12 N
Rango de ajuste tiempo de descarga		4 / 8 / 12 s
Humedad		< 100 % relativa
Rango de presión de funcionamiento		1 - 8 bar
Temperatura máx. de servicio agua		30 °C

ES

Informação geral

Estas instruções de operação

Guarde as instruções de operação e, se necessário, entregue-as a um técnico especializado.

Operação, manutenção

O operador só está autorizado a efectuar os trabalhos de manutenção do modo descrito nestas instruções.

Serviço

Apenas um técnico especializado está autorizado a efectuar trabalhos de reparação. Trabalhos incorrectos podem provocar acidentes, danos materiais e falhas de funcionamento.

Grupo-alvo





PT

O presente documento destina-se a pessoas qualificadas, em conformidade com a norma EN IEC 62079:2001.

Utilização adequada

Os sistemas de descarga para urinol HyTouch destinam-se à descarga de urinóis cerâmicos. Em caso de uso inadequado, refutamos toda e qualquer responsabilidade e direitos a garantia em caso de danos pessoais ou materiais.

Explicação dos símbolos

Símbolo	Significado
	CUIDADO Indica uma eventual situação de perigo que pode causar ferimentos ligeiros ou de média gravidade ou danos materiais.
	Utilizar massa lubrificante!
	Não corre água da torneira
	Corre água da torneira

Contacto

Em caso de dúvidas ou problemas, entre em contacto com a sua empresa de marketing e vendas Geberit competente ou com www.geberit.com.

Estrutura

HyTouch sistema pneumático de descarga para urinol

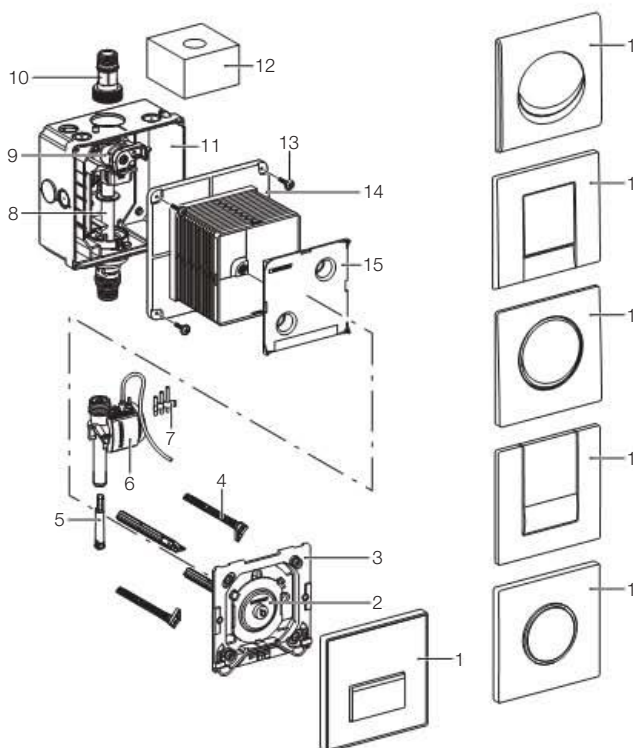

- 1 Placa de comando de descarga
- 2 Dispositivo de elevação pneumático
- 3 Aro de fixação
- 4 Cavilha de ajustamento
- 5 Dispositivo limitador da taxa de fluxo
- 6 Válvula pneumática
- 7 Conjunto de bocais
- 8 Tubo para cabos eléctricos
- 9 Válvula de fecho com válvula reguladora
- 10 Bico de ligação
- 11 Caixa interior
- 12 Borracha protectora
- 13 Parafusos de fixação
- 14 Tampa de protecção
- 15 Tampa de protecção da caixa de acesso

Manutenção

Intervalo para manutenção

Efectuar os seguintes trabalhos de manutenção quando necessário, mas o mais tardar nos intervalos indicados:

- Limpar a superfície da placa de comando de descarga - semanalmente, pelo operador
- Limpar o filtro tipo cesto - de 2 em dois anos, por um técnico especializado

Trabalho de manutenção

Limpar a placa de comando de descarga



CUIDADO

Produtos de limpeza agressivos e abrasivos podem danificar a superfície.

- ▶ Não utilizar produtos de limpeza que contenham cloro ou ácidos ou sejam abrasivos ou corrosivos, mas apenas produtos de limpeza suaves e água



Não serão aceites reclamações por danos causados devido ao uso incorrecto de produtos de limpeza.

Limpar ou substituir o filtro tipo cesto



Serviço

Detecção do erro

Problema	Possível causa	Medida a tomar
Água não escoa	A válvula de entrada de água está fechada	Abrir a válvula de entrada de água
	O filtro tipo cesto está obstruído ou sujo	Limpar ou substituir o filtro tipo cesto • Ver "Manutenção, limpar ou substituir o filtro tipo cesto"
	Falta pressão na distribuição de água	Verificar pressão da água • Repor a pressão da água
	A ligação à tomada da mangueira pneumática entre botão pneumático e válvula pneumática está desligada	Estabelecer a ligação à tomada da mangueira pneumática
Fluxo contínuo (água não pára de escoar)	A mangueira pneumática está amolgada ou partida	Substituir a mangueira pneumática danificada
	A válvula pneumática está danificada	Substituir a válvula pneumática • Ver "Serviço, substituir válvula pneumática"
Lavagem insuficiente do urinol cerâmico	A válvula pneumática está danificada	Substituir a válvula pneumática • Ver "Serviço, substituir válvula pneumática"
Projecção de água do urinol cerâmico	Válvula reguladora com abertura insuficiente	Abrir válvula reguladora
	Taxa de fluxo demasiado elevada	Montar o dispositivo limitador da taxa de fluxo • O dispositivo limitador da taxa de fluxo encontra-se disponível como acessório (242.484.00.1)

Trabalhos de reparação

Estas instruções de serviço mostram o comando com conduta de água vertical (A). O comando com conduta de água horizontal (B) não é apresentado, os trabalhos de reparação são, no entanto, os mesmos.

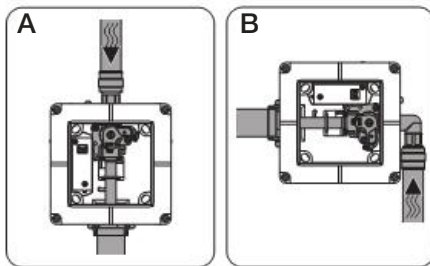

Aqui são descritos os seguintes trabalhos de reparação:

- Desmontar a placa de comando de descarga e o aro de fixação
- Substituir a válvula pneumática
- Substituir o parafuso regulador
- Substituir o O'ring do tubo de descarga
- Montar o aro de fixação e a placa de comando de descarga

Desmontar a placa de comando de descarga e o aro de fixação

1

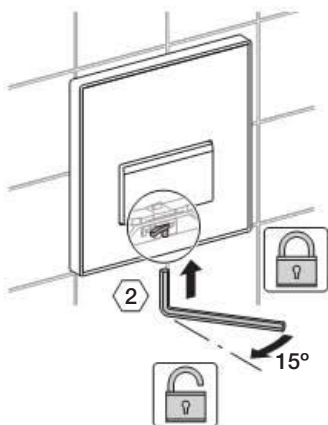

2

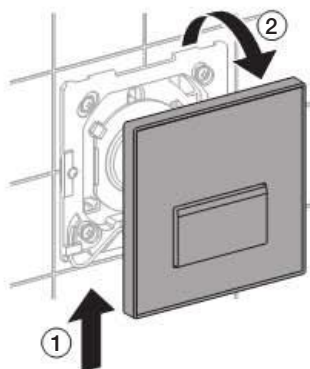

3

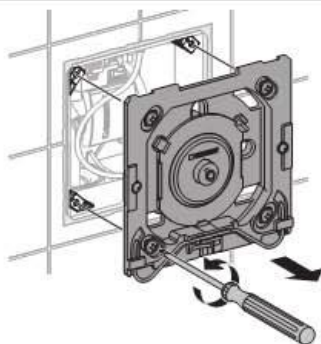

4

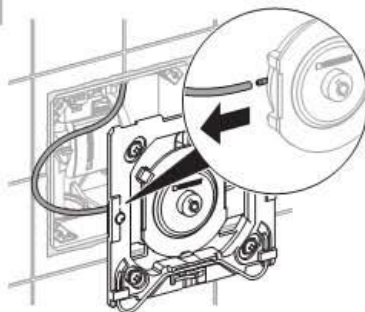

PT

Substituir a válvula pneumática

Pré-requisitos

A placa de comando de descarga e o aro de fixação estão desmontados.

Ver "Serviço, desmontar a placa de comando de descarga e o aro de fixação".

1

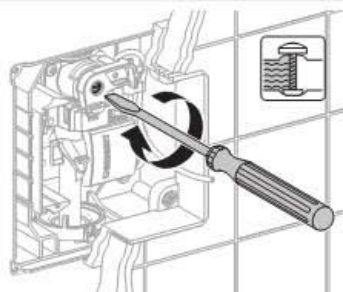

2

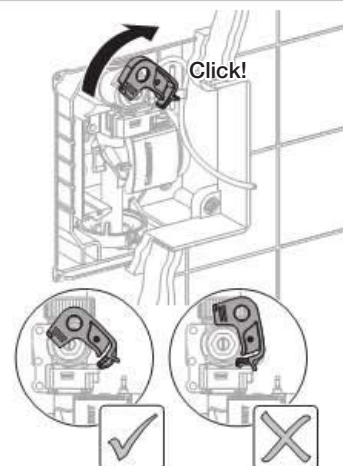

Serviço

3

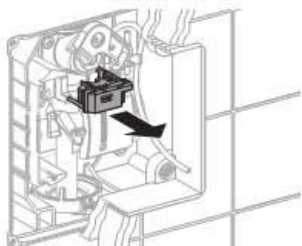

4

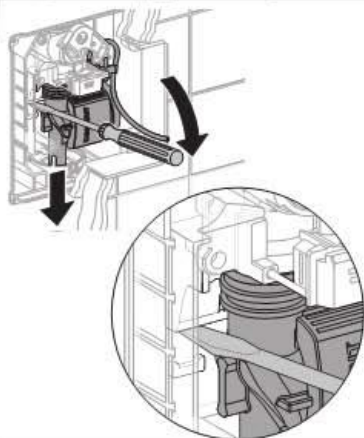

5

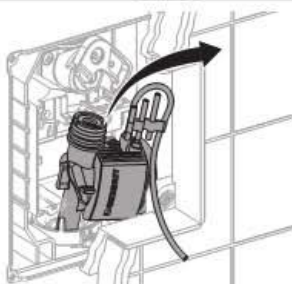

6

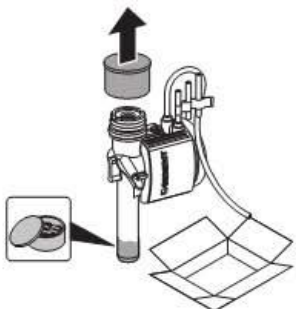

7

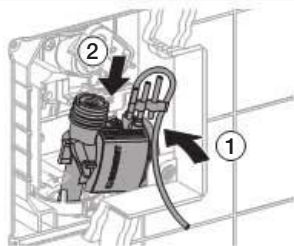

8

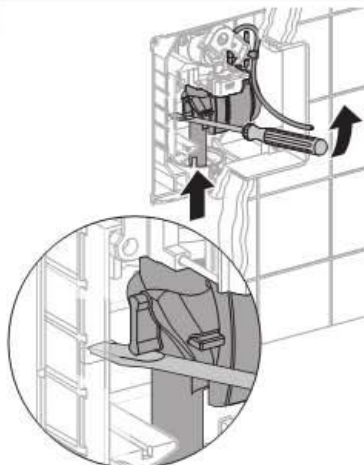

9

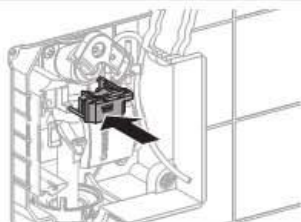

10

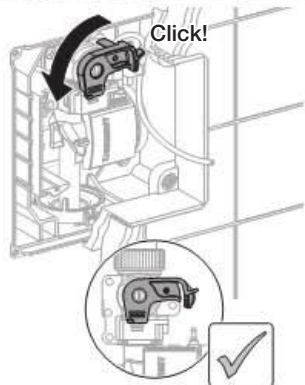

Substituir o parafuso regulador

Pré-requisitos

A placa de comando de descarga e o aro de fixação estão desmontados.

Ver "Serviço, desmontar a placa de comando de descarga e o aro de fixação".

1

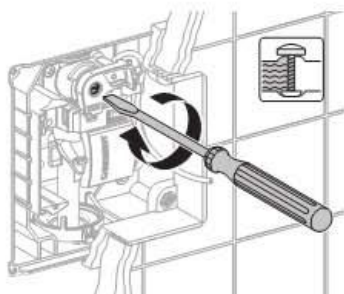

2 Fechar a válvula central de entrada de água.

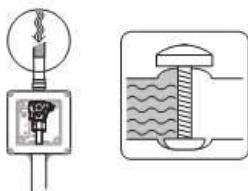

3

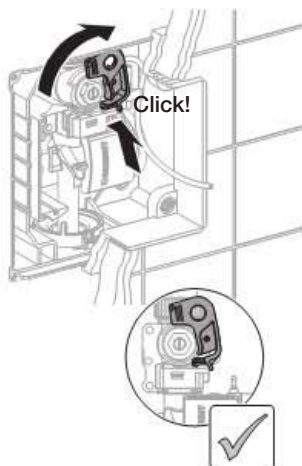

4

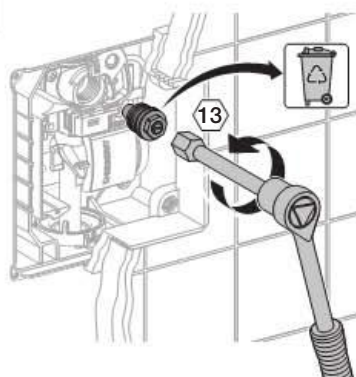

5

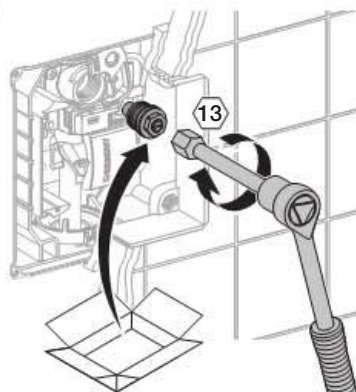

6

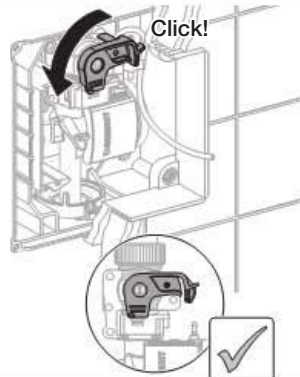

7 Abrir a válvula central de entrada de água.



PT

Substituir o O'ring do tubo de descarga

Pré-requisitos

A placa de comando de descarga e o aro de fixação estão desmontados.

Ver "Serviço, desmontar a placa de comando de descarga e o aro de fixação".

1

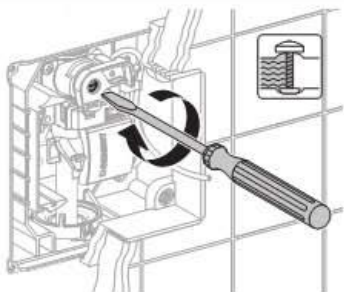

2

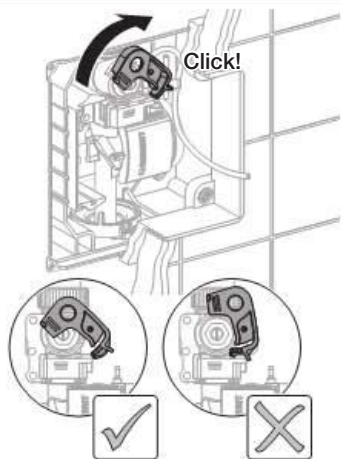

3

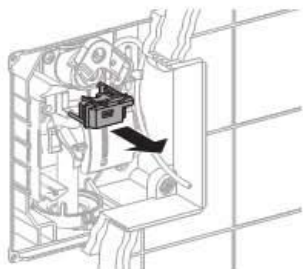

4

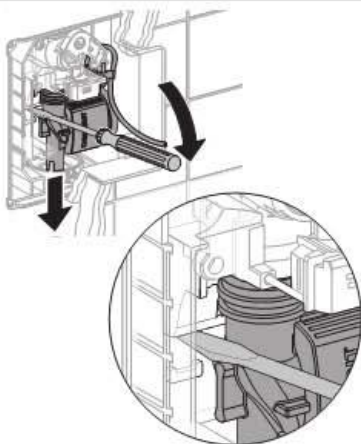

5

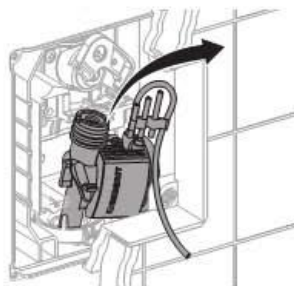

6

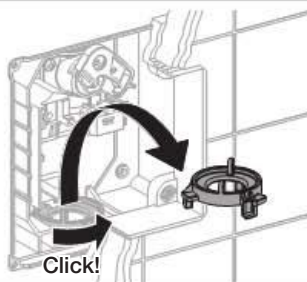

7

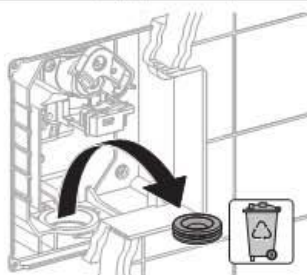

8



9

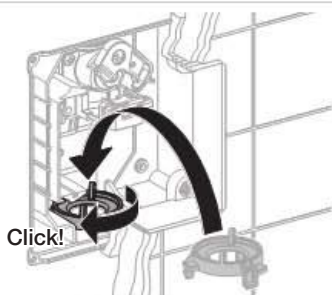

10

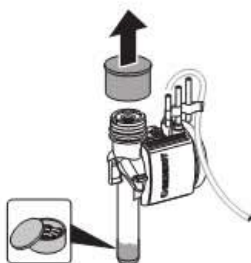

11

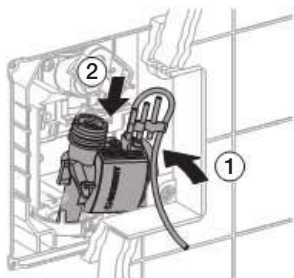

12

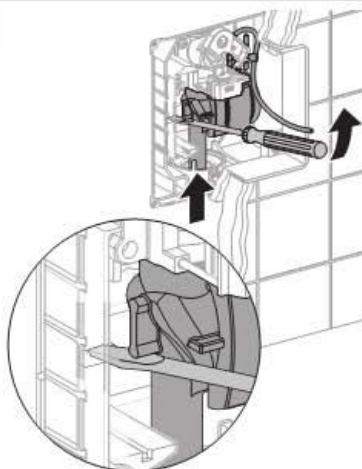

13

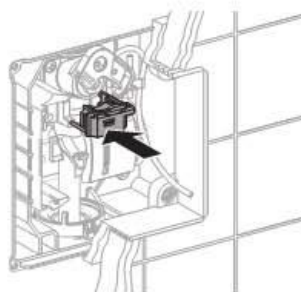

14

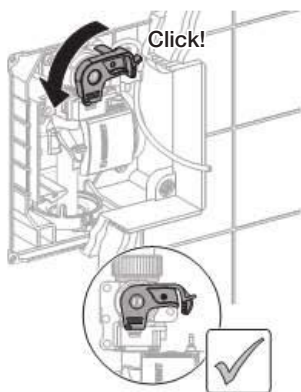

PT

Montar o aro de fixação e a placa de comando de descarga

1

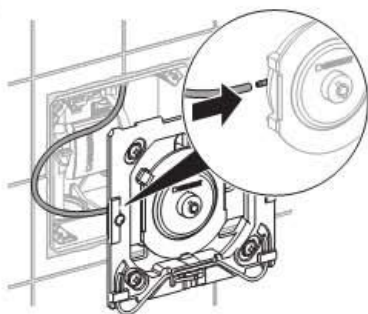

2

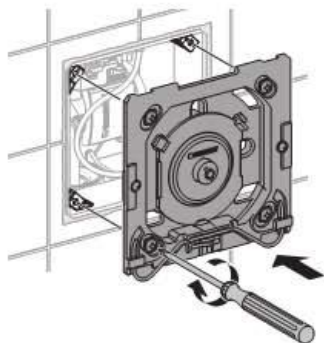

3

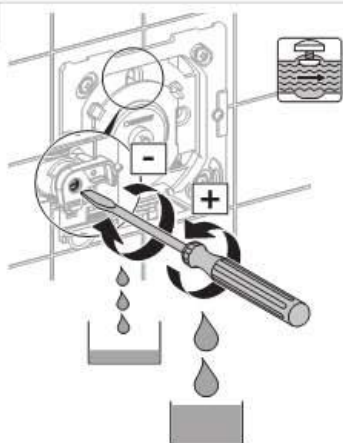

4

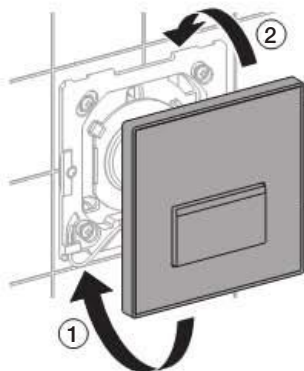

5

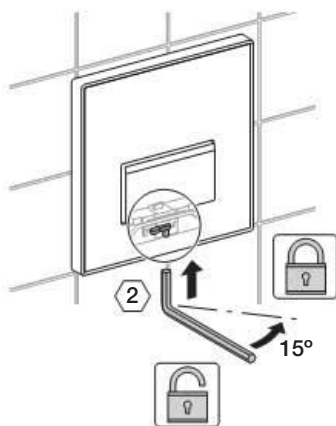

Dados técnicos

HyTouch sistema pneumático de descarga para urinol

Taxa de fluxo com 1 bar	0,3 / 0,24 (com dispositivo limitador da taxa de fluxo)	l/s
Teste de pressão com água		16 bar
Teste de pressão com ar		3 bar
Força de accionamento		< 12 N
Definição do tempo de descarga		4 / 8 / 12 s
Humidade		< 100 %, relativa
Pressão de serviço		1 - 8 bar
Temperatura máxima da água em serviço		30 °C

PT

Generelle informationer

Denne driftsvejledning

Opbevar driftsvejledningen, og udlever den til fagmanden, hvis han har brug for den.

Drift, vedligeholdelse

Vedligeholdelsesarbejde må kun udføres af den driftsansvarlige i det omfang, det er beskrevet i denne vejledning.

Service

Servicearbejde må kun gennemføres af en fagmand. Ukorrekt arbejde kan medføre uheld, materielle skader og driftsforstyrrelser.

Målgruppe





Dette dokument henvender sig til fagfolk ifølge EN IEC 62079:2001.

DK

Korrekt anvendelse

HyTouch urinalstyringer er beregnet til skyl af urinalkeramik. Anvendes de til andre formål, bortfalder garantikrav og ansvarskrav, der måtte opstå i forbindelse med personskader og materielle skader.

Symbolforklaring

Symbol	Betydning
	FORSIGTIG Henviser til en mulig farlig situation, som kan medføre lette eller mellemstore personskader eller materielle skader.
	Brug fedt!
	Ledningsvand er frakoblet
	Ledningsvand er tilkoblet

Kontakt

Hvis De har spørgsmål eller problemer, bedes De kontakte Deres Geberit salgsselskab eller gå ind på internettet under www.geberit.com.

Opbygning

HyTouch urinalstyring pneumatik

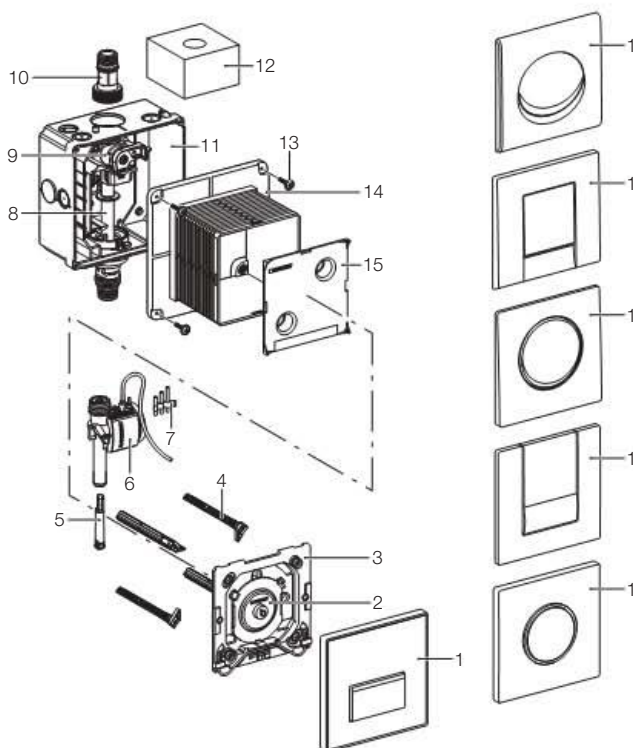

- 1 Betjeningsplade
- 2 Pneumatisk knap
- 3 Montageramme
- 4 Afstandsbolt
- 5 Gennemstrømningsbegrænser
- 6 Pneumatisk ventil
- 7 Dysesæt
- 8 Tomrør
- 9 Stopventil med drossel
- 10 Tilslutningsnippel
- 11 Indbygningsdel
- 12 Beskyttelsessvamp
- 13 Montageskruer
- 14 Beskyttelsesramme
- 15 Beskyttelsesplade

Vedligeholdelse

Vedligeholdelsesinterval

Følgende vedligeholdelsesarbejde skal gennemføres efter behov, dog senest i de angivne intervaller:

- Rengøring af betjeningspladens overflade - hver uge, af den driftsansvarlige
- Rengøring af kurvefilteret - hvert 2. år, af en fagmand

Vedligeholdelsesarbejde

Rengøring af betjeningspladen



FORSIGTIG

Aggressive og skurende rengøringsmidler kan beskadige overfladen.

- Anvend aldrig klorholdige, syreholdige, slibende eller ætsende rengøringsmidler, men kun milde rengøringsmidler og vand



Reklamationer, der forårsages på grund af ukorrekt behandling med rengøringsmidler, kan ikke anerkendes.

Rengøring eller udskiftning af kurvefilteret



DK

Service

Fejlsøgning

Problem	Mulig årsag	Afhjælpning
Der løber ikke vand ud	Vandtilførslen er lukket	Åbn vandtilførslen
	Kurvefilteret er forstoppet eller tilsnudet	Rengør eller udskift kurvefilteret • Se "Vedligeholdelse, rengøring eller udskiftning af kurvefilteret"
	Intet tryk på vandforsyningen	Kontrollér vandtrykket • Genopret vandtrykket
	Luftslangens stikforbindelse mellem den pneumatiske knap og den pneumatiske ventil er afbrudt	Etablér luftslangens stikforbindelse
	Luftslangen er bøjet eller knækket	Udskift den defekte luftslange
Vedvarende vandudløb (vandet stopper ikke)	Den pneumatiske ventil er defekt	Udskift den pneumatiske ventil • Se "Service, udskiftning af pneumatisk ventil"
	Urinalkeramikken skylles ikke tilstrækkeligt	Åbn for droslen
Der sprøjtes skyllevand ud af urinalkeramikken	For stor gennemstrømningsmængde	Monér en gennemstrømningsbegrænser • Gennemstrømningsbegrænseren fås som tilbehør (242.484.00.1)

Servicearbejde

Denne servicevejledning viser styringen med lodret vandføring (A). Styringen med vandret vandføring (B) vises ikke, men servicearbejdet er det samme.

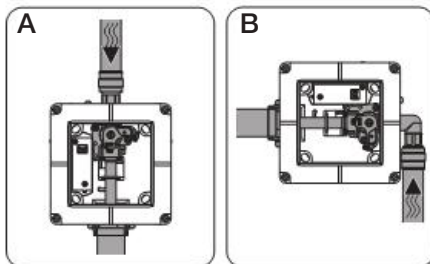

Følgende servicearbejde er beskrevet her:

- Afmontering af betjeningspladen og monteragerammen
- Udskiftning af den pneumatiske ventil
- Udskiftning af drosselskruen
- Udskiftning af skyllerørets læbetætning
- Montering af monteragerammen og betjeningspladen

Afmontering af betjeningspladen og monteragerammen

1

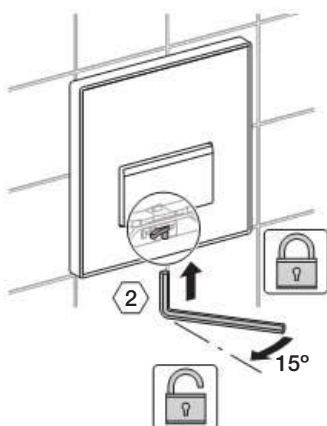

2

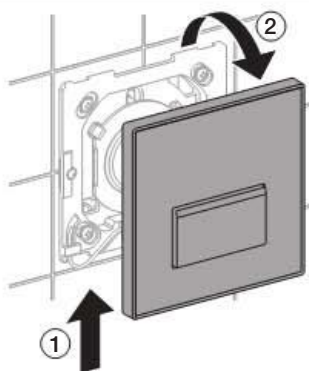

3

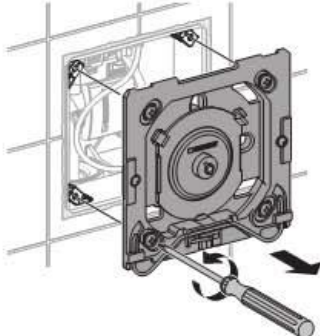

4

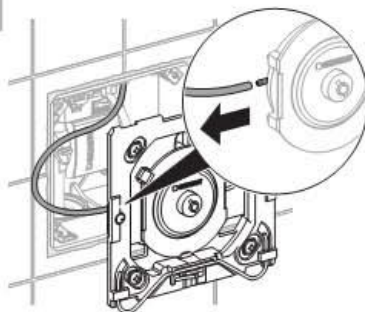

Udskiftning af den pneumatiske ventil

Forudsætninger

Betjeningspladen og monteragerammen er afmonteret.

Se "Service, afmontering af betjeningspladen og monteragerammen".

1

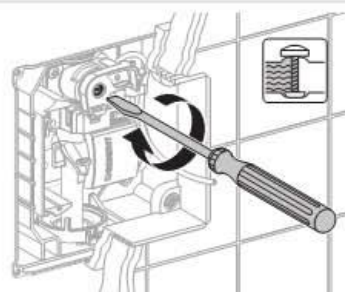

2

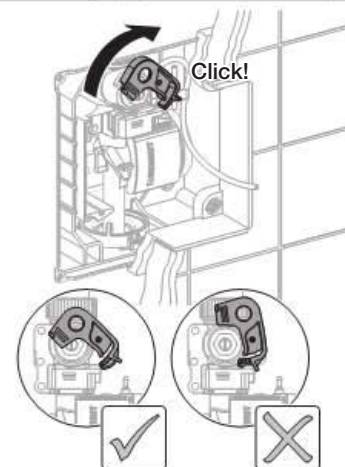

3

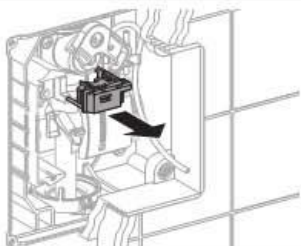

4

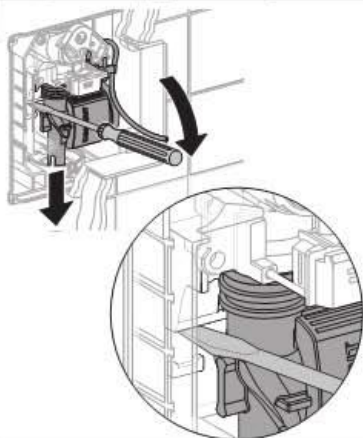

5

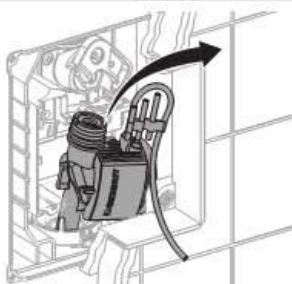

6

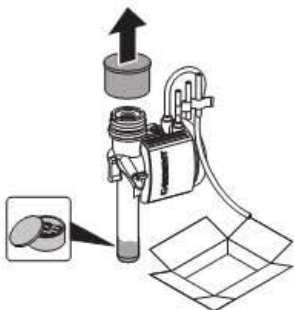

7

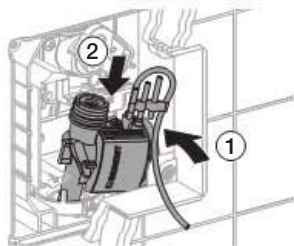

8

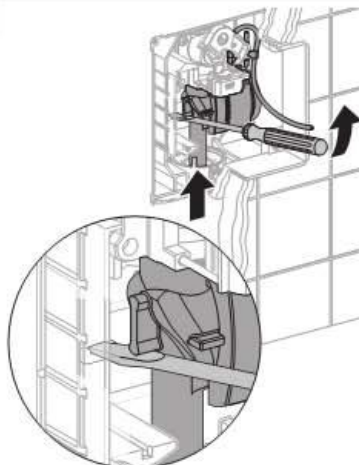

9

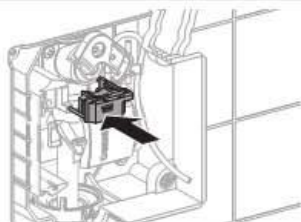

10

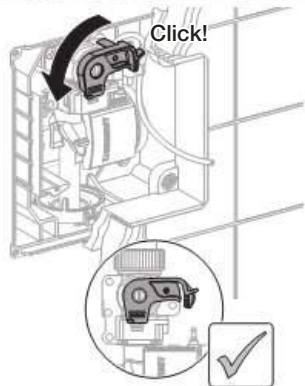

Udskiftning af drosselskruen

Forudsætninger

Betjeningspladen og montererammen er afmonteret.

Se "Service, afmontering af betjeningspladen og montererammen".

1

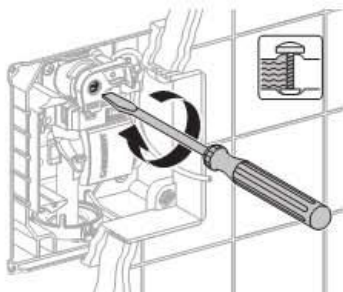

2 Luk for den centrale vandtilførsel.

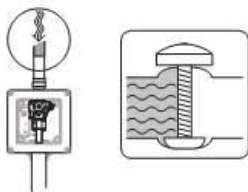

3

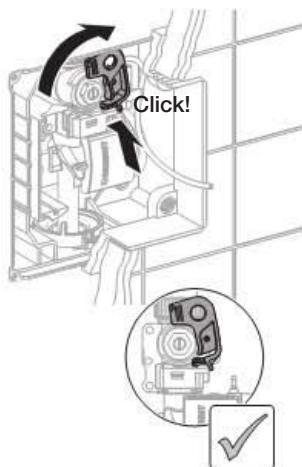

4

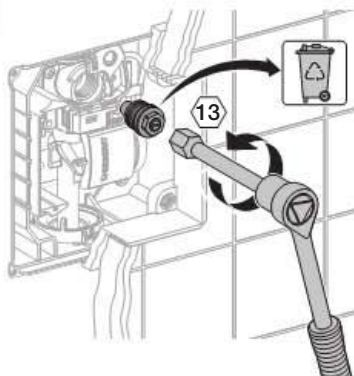

5

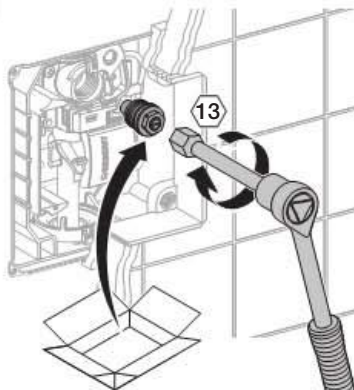

6

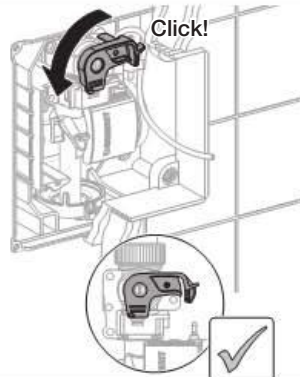

7 Åbn for den centrale vandtilførsel.



Udskiftning af skyllerørets læbetætning

Forudsætninger

Betjeningspladen og montagerammen er afmonteret.

Se "Service, afmontering af betjeningspladen og montagerammen".

1

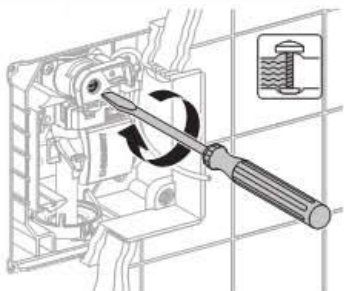

2

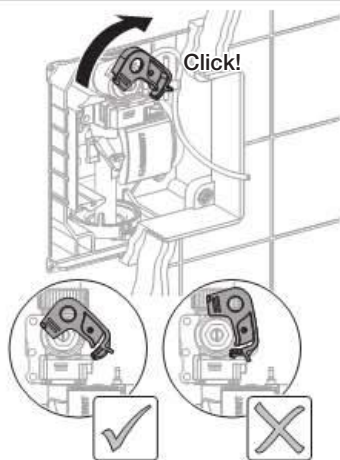

3

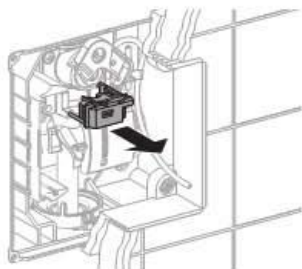

4

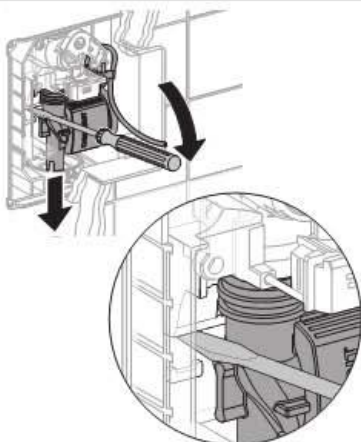

5

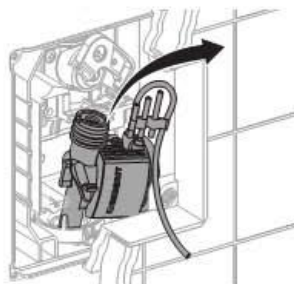

6

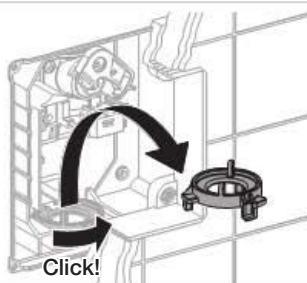

7

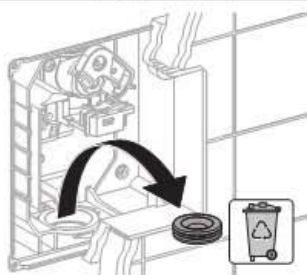

8



9

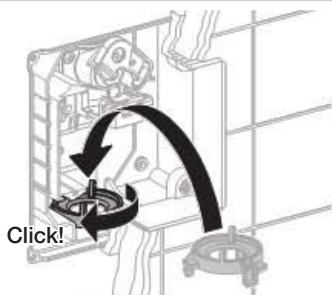

10

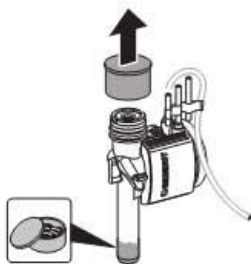

11

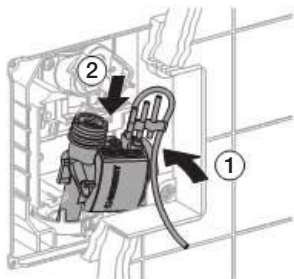

12

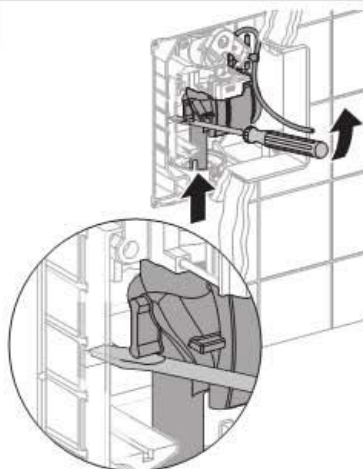

DK

13

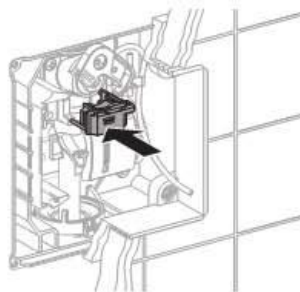

14

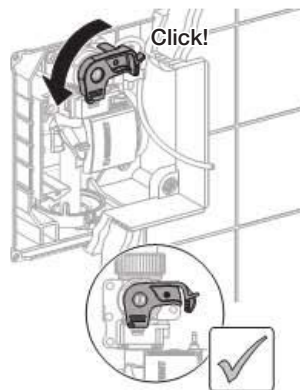

Montering af montererammen og betjeningspladen

1

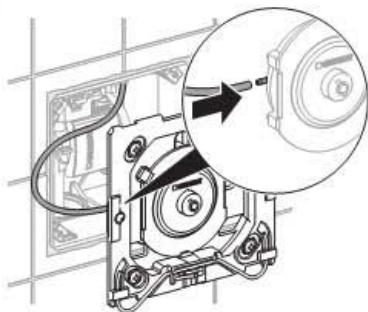

2

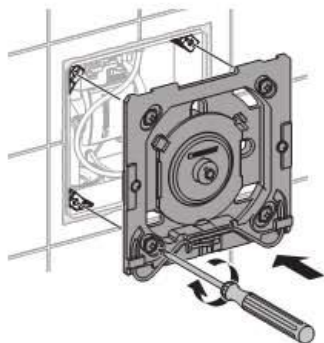

3

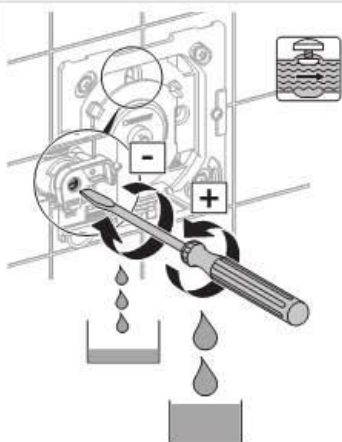

4

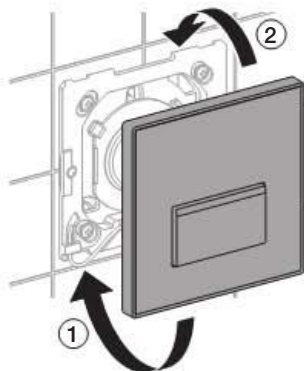

5

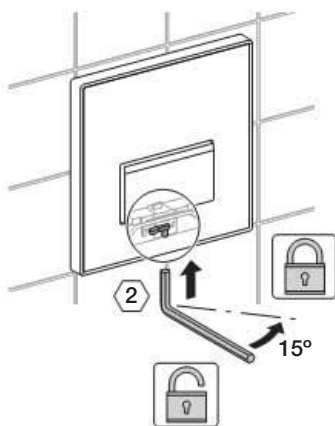

Tekniske data

HyTouch urinalstyring pneumatik

Gennemstrømningsmængde ved 1 bar	0,3 / 0,24 (med gennemstrømningsbegrænser)	l/s
Prøvetryk vand		16 bar
Prøvetryk luft/inaktiv gas		3 bar
Betjeningskraft		< 12 N
Indstillingsområde for skylletid		4 / 8 / 12 s
Luftfugtighed		< 100 % relativ
Trykområde under brug		1 - 8 bar
Maks. vandtemperatur		30 °C

DK

Generelle opplysninger

Denne driftsveiledningen Oppbevar driftsveiledningen og vis den til en fagperson ved behov.

Bruk, vedlikehold Brukeren må utføre vedlikeholdsarbeid bare i den grad det er beskrevet i denne driftsveiledningen.

Service Servicearbeid må bare utføres av en fagperson. Ikke-forskriftsmessig arbeid kan føre til ulykker, skader og driftsfeil.

Målgruppe





Dette dokumentet retter seg mot fagpersoner iht. EN IEC 62079:2001.

Korrekt bruk

HyTouch urinalstyringer er laget for spyling av urinalskåler. Dersom styringen brukes til annet formål, bortfaller samtlige garanti- og ansvarskrav ved personskade eller materiell skade.

NO

Symbolforklaring

Symbol	Betydning
	FORSIKTIG Gjør oppmerksom på en mulig farlig situasjon som kan medføre lett til middels personskade eller materiell skade.
	Bruk smørefett!
	Vanntilførselen er stengt
	Vanntilførselen er åpen

Kontakt

Ved spørsmål eller problemer, ta kontakt med din Geberit-forhandler eller www.geberit.no.

Konstruksjon

HyTouch urinalstyring, pneumatikk

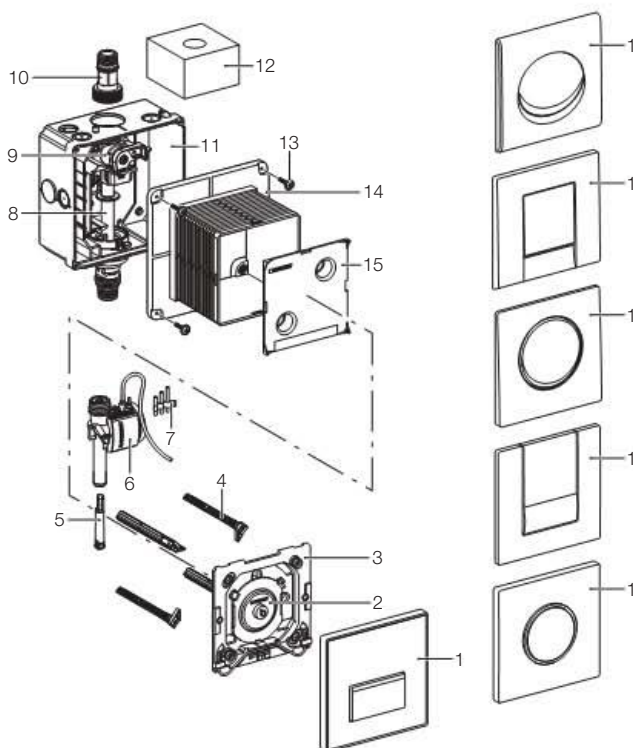

- 1 Betjeningsplate
- 2 Pneumatisk trykknapp
- 3 Monteringsramme
- 4 Avstandsbolt
- 5 Gjennomstrømningsbegrenser
- 6 Pneumatisk ventil
- 7 Dysesett
- 8 Ytterør
- 9 Stoppventil med spjeld
- 10 Tilkoplingsnippel
- 11 Innbyggingsisterne
- 12 Beskyttelsessvamp
- 13 Monteringskruer
- 14 Beskyttelseskappe
- 15 Beskyttelsesdeksel

Vedlikehold

Vedlikeholdsintervall

Følgende vedlikeholdsarbeider må utføres ved behov, men senest innen angitte intervaller:

- Rengjøre betjeningsplateoverflaten - ukentlig, av bruker
- Rengjøre kurvfilter - annethvert år, av fagperson

Vedlikeholdsarbeid

Rengjøre betjeningsplate

FORSIKTIG
Aggressive og skurende rengjøringsmidler kan skade overflaten.

- ▶ Ikke bruk klor- eller syreholdige, slpende eller etsende rengjøringsmidler. Bruk bare milde rengjøringsmidler og vann.

i Reklamasjoner som skyldes ikke-forskriftsmessig bruk av rengjøringsmidler, godtas ikke.

Rengjøre eller skifte ut kurvfilteret



Service

Feilsøking

Problem	Mulig årsak	Løsning
Det strømmer ikke vann	Vanntilførselen er stengt	Åpne vanntilførselen
	Kurvfilteret er tett eller skittent	Rengjøre eller skifte ut kurvfilteret <ul style="list-style-type: none">• Se "Vedlikehold, Rengjøre eller skifte ut kurvfilteret"
	Manglende tilførselstrykk	Sjekk vanntrykket <ul style="list-style-type: none">• Gjenopprett vanntrykket
	Pluggforbindelsen på den pneumatisk slangen mellom det pneumatisk trykkstaget og den pneumatisk ventilen er koplet fra hverandre	Kople til pluggforbindelsen på den pneumatisk slangen igjen
	Den pneumatisk slangen er knekket eller brukt	Skift ut defekt pneumatisk slange
Kontinuerlig strøm (vannstrømmen stopper ikke)	Defekt pneumatisk ventil	Skift ut pneumatisk ventil <ul style="list-style-type: none">• Se "Service, Skifte pneumatisk ventil"
	Defekt pneumatisk ventil	Skift ut pneumatisk ventil <ul style="list-style-type: none">• Se "Service, Skifte pneumatisk ventil"
Urinalskålen spyles ikke godt nok	Spjeldet er ikke tilstrekkelig åpent	Åpne spjeldet
Det spruter spylevann ut av urinalskålen	For høy gjennomstrømning	Monter gjennomstrømningsbegrenser <ul style="list-style-type: none">• Gjennomstrømningsbegrenseren leveres som tilbehør (242.484.00.1)

Servicearbeid

Denne serviceinstruksjonen viser styringen med vertikal vannkanal (A). Styringen med horisontal vannkanal (B) er ikke vist, men servicearbeidet er det samme.

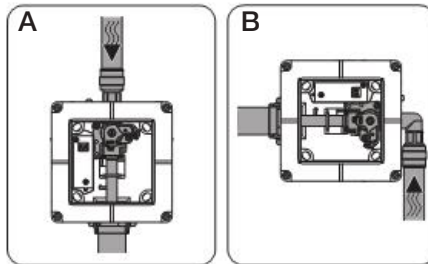

Følgende servicearbeider beskrives her:

- Demontere betjeningsplate og monteringsramme
- Skifte ut pneumatisk ventil
- Skifte ut reguleringssskruen
- Skifte leppepakningen på spyleledningen
- Montere monteringsrammen og betjeningsplaten

Demontere betjeningsplate og monteringsramme

1

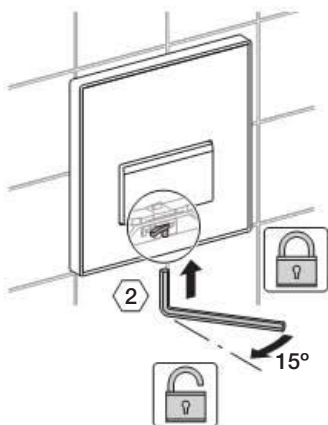

2

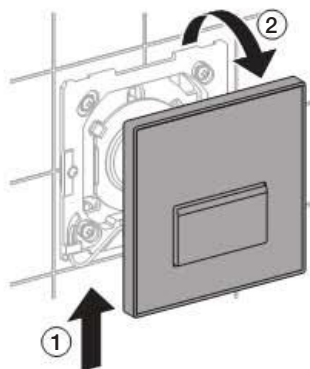

3

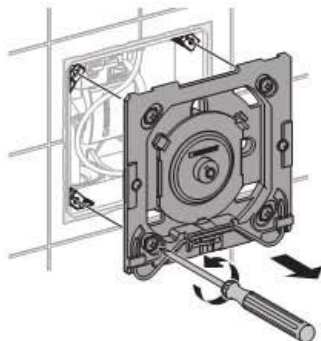

4

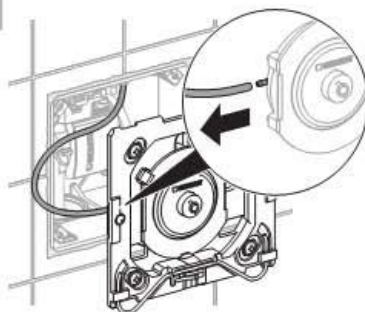

Skifte ut pneumatisk ventil

NO

Forutsetninger

Betjeningsplaten og monteringsrammen er demontert.

Se "Service, Demontere betjeningsplate og monteringsramme".

1

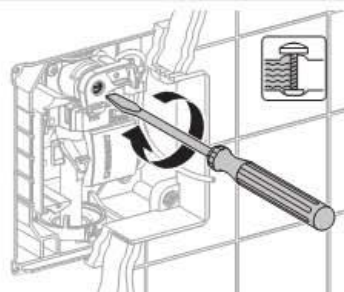

2

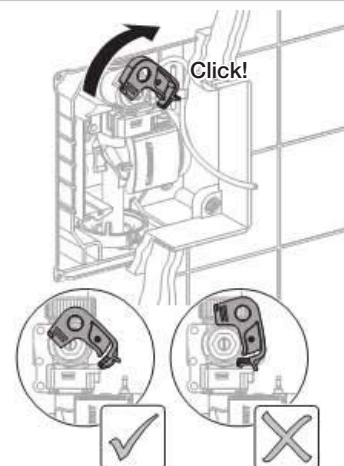

3

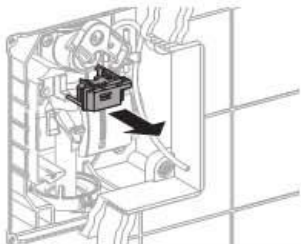

4

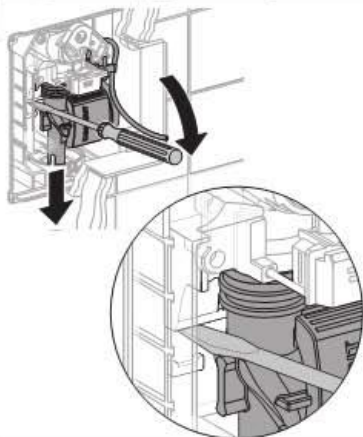

5

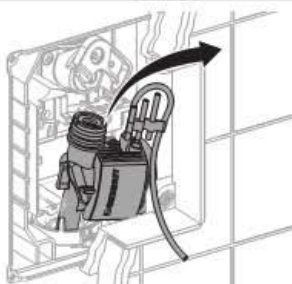

6

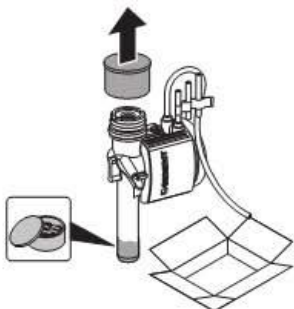

7

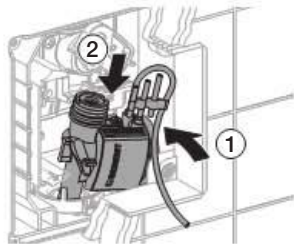

8

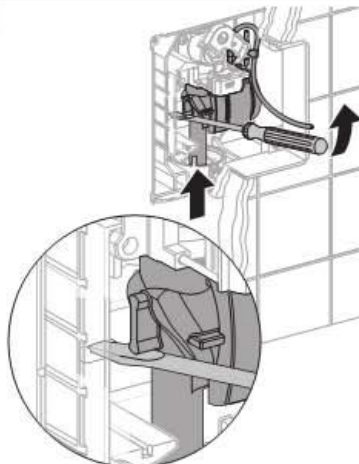

9

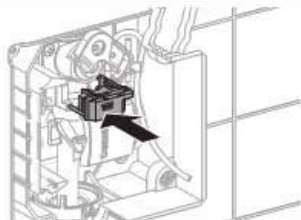

10

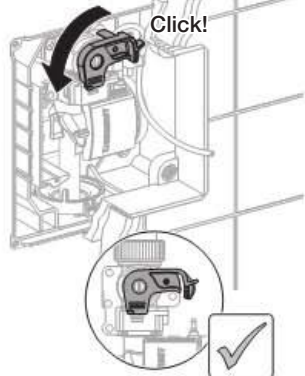

Skifte ut reguleringskruen

Forutsetninger

Betjeningsplaten og monteringsrammen er demontert.

Se "Service, Demontere betjeningsplate og monteringsramme".

1

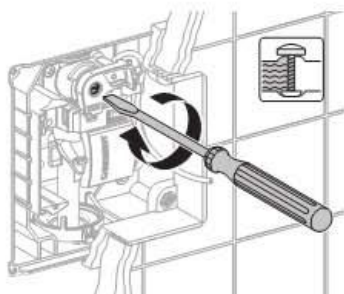

2 Steng den sentrale vanntilførselen.

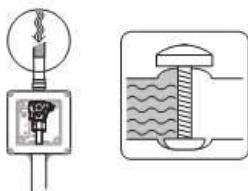

3

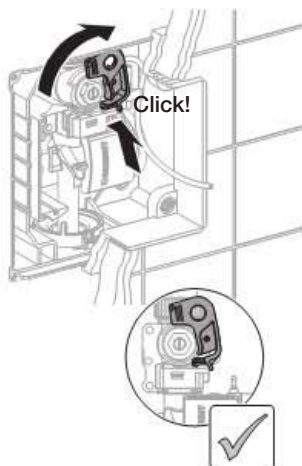

4

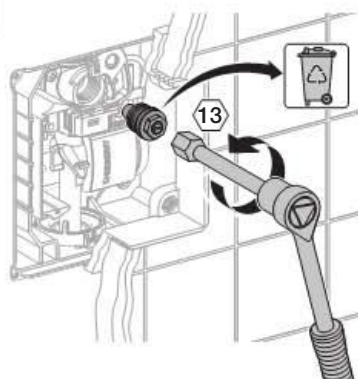

5

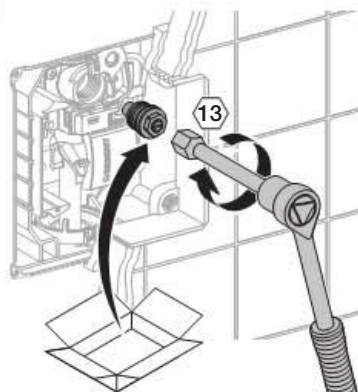

6

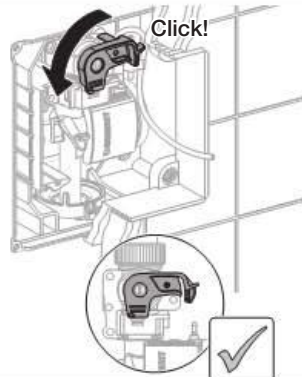

7 Åpne den sentrale vanntilførselen.



Skifte leppepakningen på spyleledningen

Forutsetninger

Betjeningsplaten og monteringsrammen er demontert.

Se "Service, Demontere betjeningsplate og monteringsramme".

1

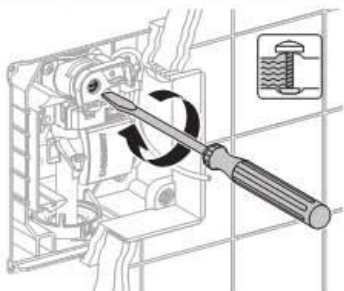

2

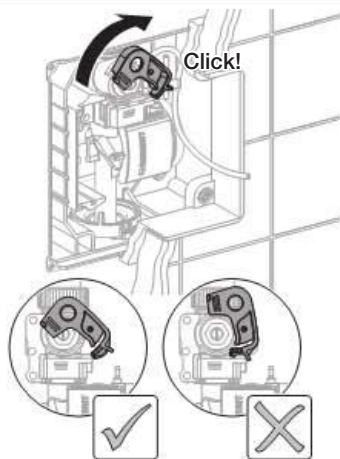

3

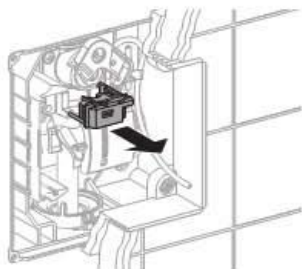

4

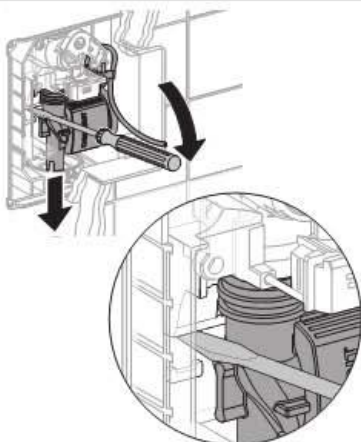

5

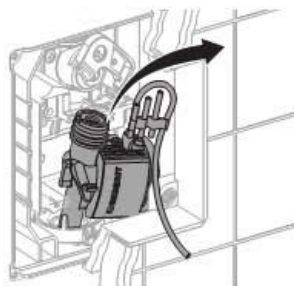

6

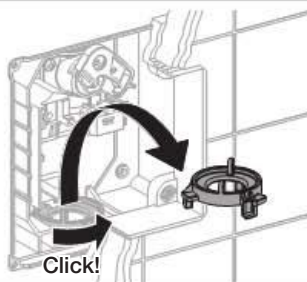

7

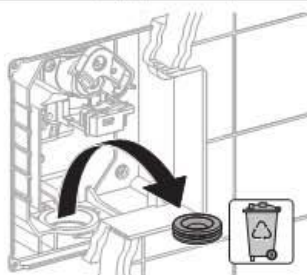

8



9

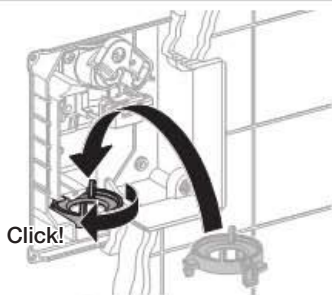

10

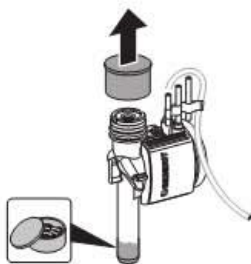

11

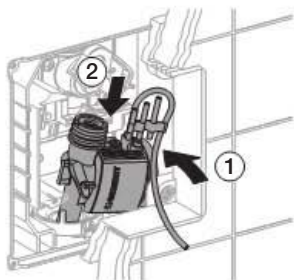

12

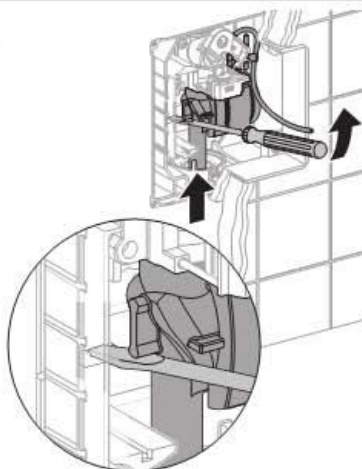

13

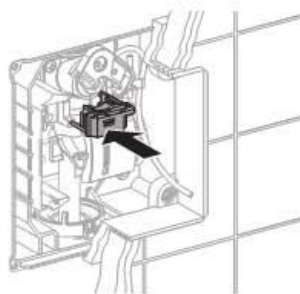

14

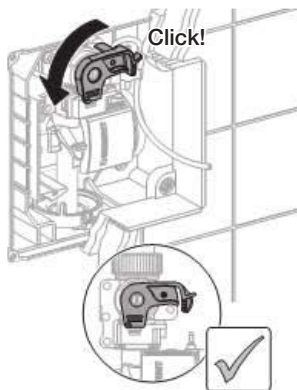

Montere monteringsrammen og betjeningsplaten

1

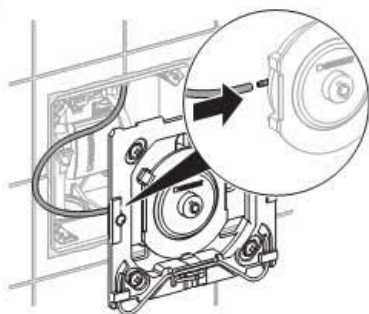

2

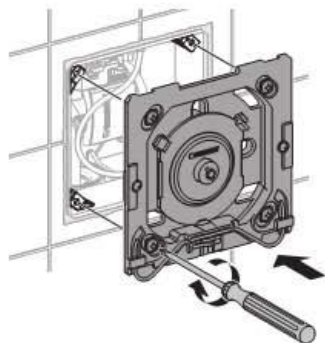

3

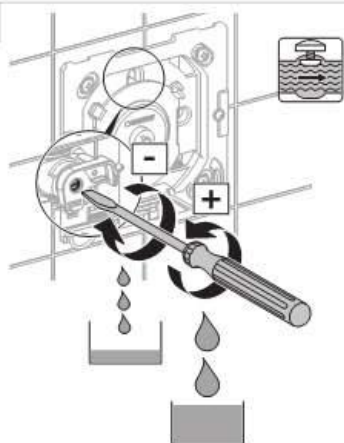

4

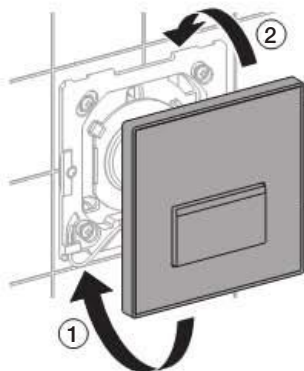

5

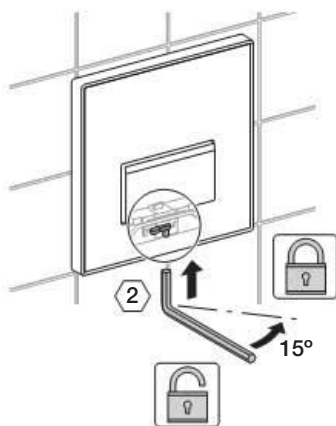

Tekniske data

HyTouch urinalstyring, pneumatikk

Gjennomstrømningsmengde ved 1 bar	0,3 / 0,24 (med gjennomstrømningsbegrenser) l/s
Prøvetrykk vann	16 bar
Prøvetrykk luft/inertgass	3 bar
Betjeningskraft	< 12 N
Innstillingsområde for spyletid	4 / 8 / 12 s
Relativ luftfuktighet	< 100 % relativ
Trykkområde under drift	1 - 8 bar
Driftstemperatur vann maks.	30 °C

NO

Allmän information

Denna driftinstruktion

Denna driftinstruktion skall förvaras och vid behov vara tillgänglig för fackpersonalen.

Drift, underhåll

Ägaren får endast utföra de underhållsarbeten som beskrivs i denna instruktion.

Service

Servicearbeten får endast utföras av fackpersonal. Felaktigt utförda arbeten kan leda till olyckor, materiella skador och driftstörningar.

Målgrupp





Detta dokument är avsett för fackmän enligt EN IEC 62079:2001.

Ändamålsenlig användning

HyTouch urinalstyrningar används för spolning av porlin. Vid icke ändamålsenlig användning gäller inte garanti- och ansvarsförbindelser för person- och materiella skador.

SE

Symbolförklaring

Symbol	Betydelse
	OBSERVERA Varnar för möjlig, farlig situation som kan leda till lätta eller medelsvåra personskador eller materiella skador.
	Använd smörjfett!
	Tappvattnet är avstängt
	Tappvattnet är på

Kontakt

Vid frågor eller problem: Kontakta din Geberit återförsäljare eller gå in på www.geberit.com.

Uppbyggnad

HyTouch urinalstyrning pneumatik

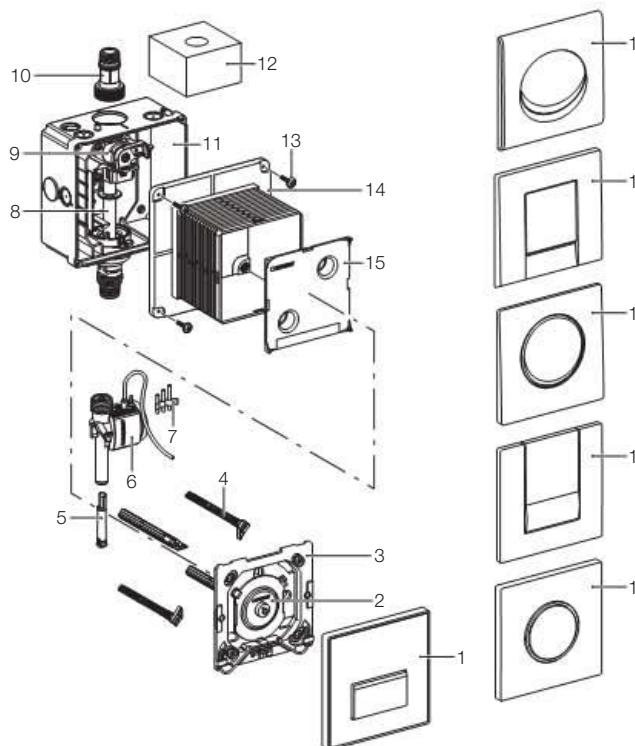

- 1 Manövreringsplatta
- 2 Pneumatisk tryckknapp
- 3 Monteringsram
- 4 Distansbult
- 5 Flödesbegränsare
- 6 Pneumatisk ventil
- 7 Munstyckssats
- 8 Vattenrör
- 9 Avstängningsventil med strypventil
- 10 Kopplingsnippl
- 11 Inbyggnad för dolt montage
- 12 Skyddssvamp
- 13 Fästskruvar
- 14 Skydd
- 15 Skyddskåpa

Underhåll

Underhållsintervall

Följande underhållsarbeten ska utföras vid behov, dock senast inom angivna intervaller:

- Rengöring av manövreringsplattan – görs av användaren varje vecka
- Rengöring av korgfiltret - görs av fackman vartannat år

Underhållsarbeten

Rengöring av manövreringsplattan

OBSERVERA
Aggressiva rengöringsmedel och skurmedel kan skada ytan.

- Använd inga klor- eller syrehaltiga, frätande eller slipande medel utan bara milda rengöringsmedel och vatten.

i Reklamationer som orsakats av att felaktiga rengöringsmedel använts kan inte godkännas.

Rengör eller byt ut korgfiltret



SE

Service

Felsökning

Problem	Möjlig orsak	Åtgärd
Vattnet rinner inte	Tilloppsventilen för vatten är stängd	Öppna tillloppsventilen för vatten
	Korgfiltret är igensatt eller smutsigt	Rengör eller byt ut korgfiltret • Se "Underhåll, rengör eller byt ut korgfiltret"
	Inget tryck i vattennätet	Kontrollera vattentrycket • Återställ vattentrycket
	Den pneumatiska slangen mellan den pneumatiska tryckknappen och den pneumatiska ventilen har lossnat	Anslut den pneumatiska slangen
	Den pneumatiska slangen är vikt eller bruten	Byt ut den defekta pneumatiska slangen
Vattnet rinner hela tiden och stängs inte av	Den pneumatiska ventilen är defekt	Byt ut den pneumatiska ventilen • Se "Service, byte av pneumatisk ventil"
	Den pneumatiska ventilen är defekt	Byt ut den pneumatiska ventilen • Se "Service, byte av pneumatisk ventil"
Porslinet spolat inte tillräckligt	Ventilen öppnar för lite	Öppna ventilen
Spolvatten sprutar ut ur porslinet	För hög flödesnivå	Montera en flödesbegränsare • Flödesbegränsaren finns som tillbehör (242.484.00.1)

Servicearbeten

Denna serviceanvisning visar styrningen med vertikal vattenledning (A). Styrningen med horisontell vattenledning (B) visas inte, men servicearbeten är likadana.

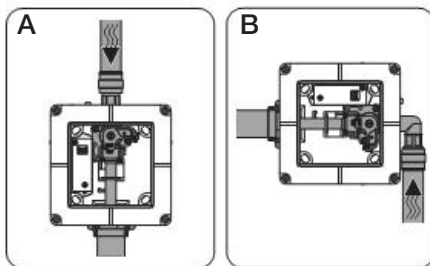

Följande servicearbeten beskrivs här:

- Demontera manövreringsplatta och monteringsram
- Byt ut den pneumatiska ventilen
- Byt ut regleringsskruven
- Byt ut läpptätningen för spolledningen
- Montera monteringsramen och manövreringsplattan

Demontering av manövreringsplattan och monteringsramen

1

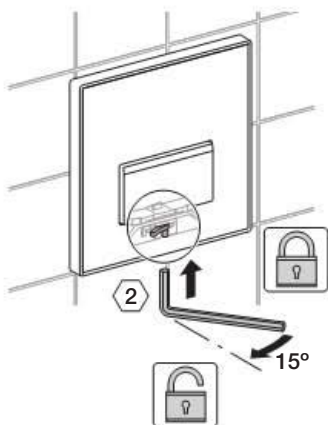

2

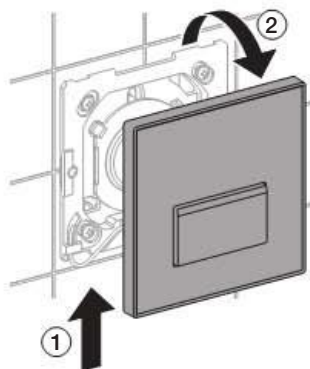

3

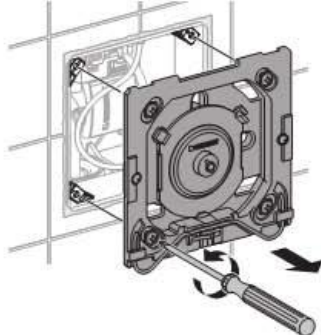

4

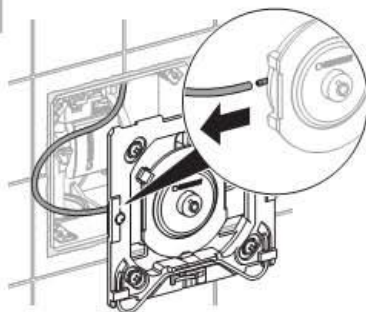

Byt ut den pneumatiska ventilen

Förutsättningar

Manövreringsplattan och monteringsramen är demonterade.

Se "Service, demontering av manövreringsplatta och monteringsram".

1

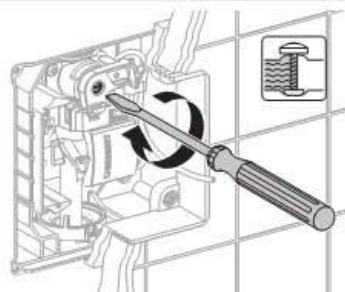

2

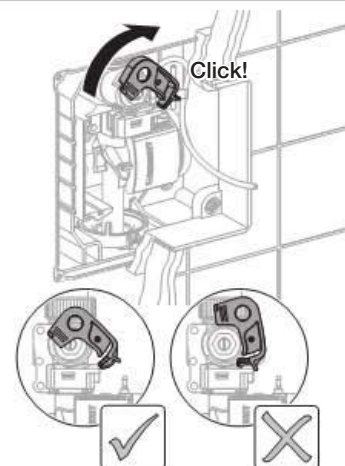

3

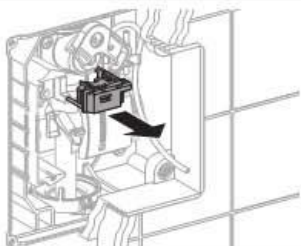

4

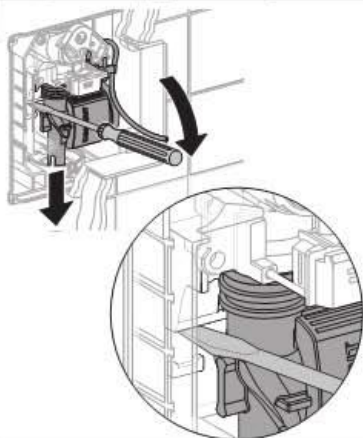

5

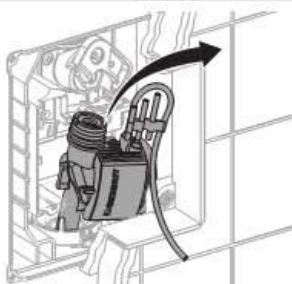

6

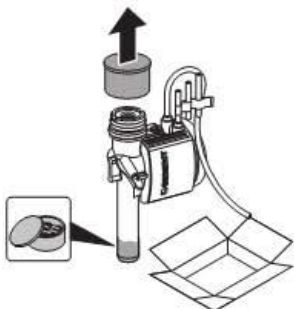

7

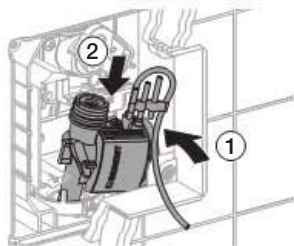

8

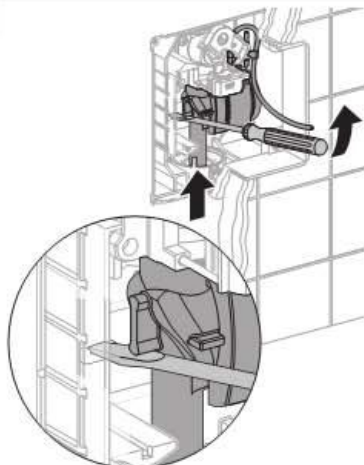

9

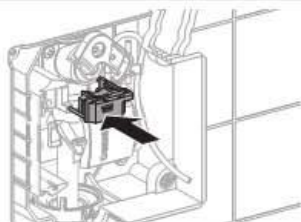

10

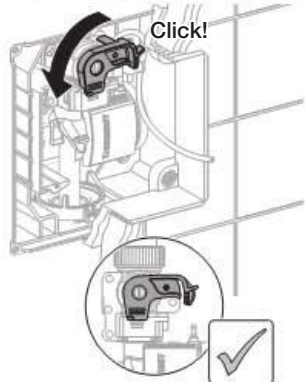

Byt ut regleringskraven

Förutsättningar

Manövreringsplattan och monteringsramen är demonterade.

Se "Service, demontering av manövreringsplatta och monteringsram".

1

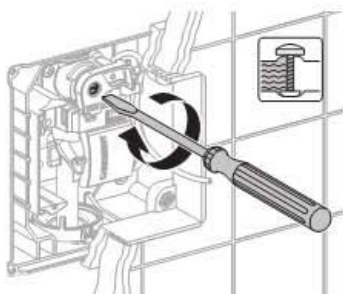

2 Stäng av huvudkranen.

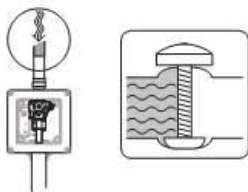

3

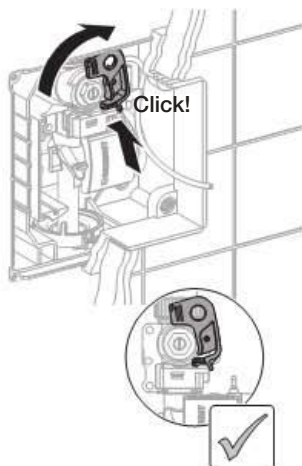

4



5

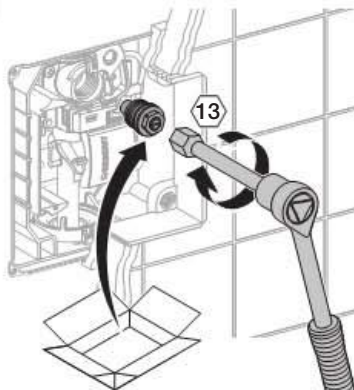

6

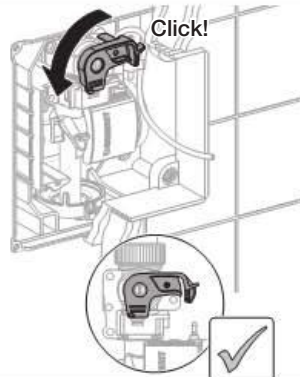

7

Öppna huvudkranen.



Byt ut läpptätningen för spolledningen

Förutsättningar

Manövreringsplattan och monteringsramen är demonterade.

Se "Service, demontering av manövreringsplatta och monteringsram".

1

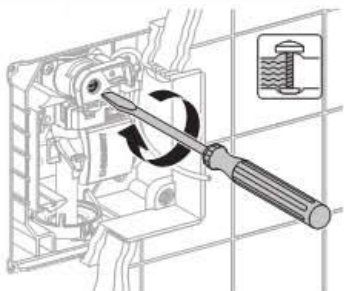

2

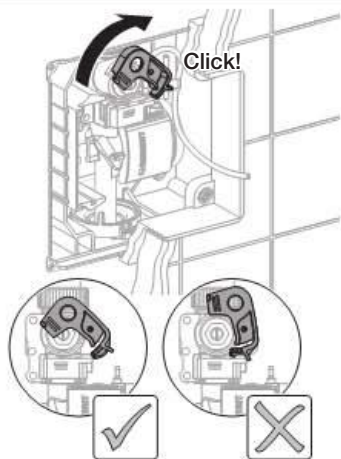

3

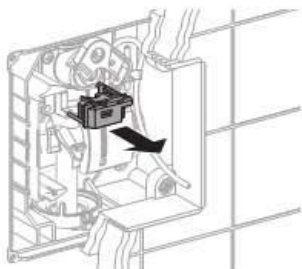

4

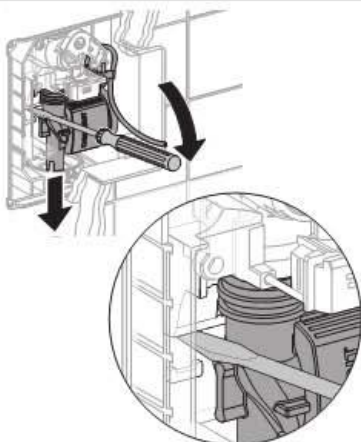

5

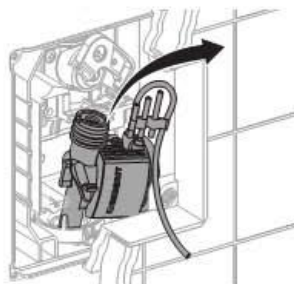

6

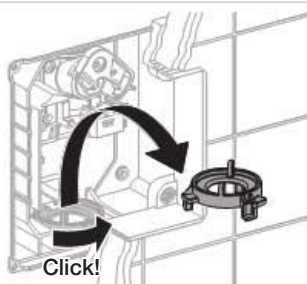

7

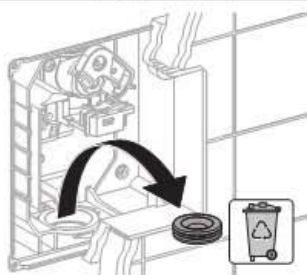

8



9

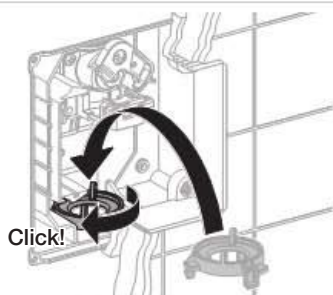

10

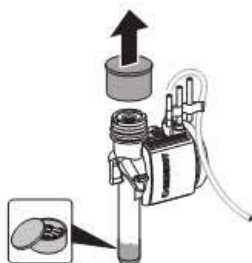

11

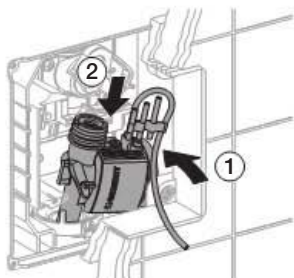

12

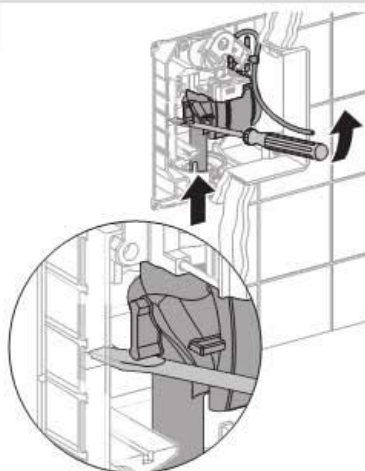

13

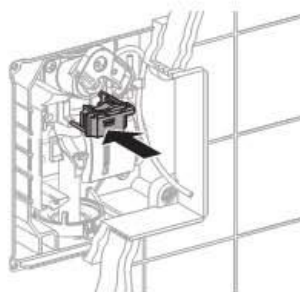

14

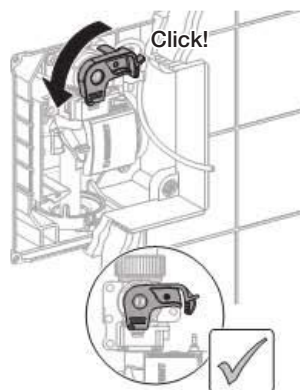

Montera monteringsramen och manövreringsplattan

1

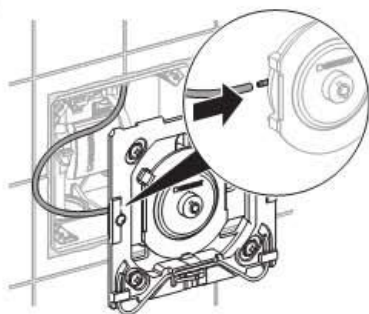

2

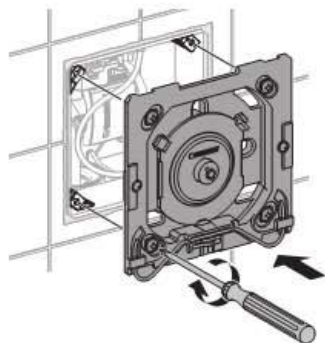

3

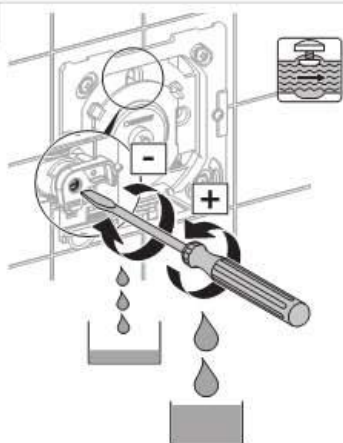

4

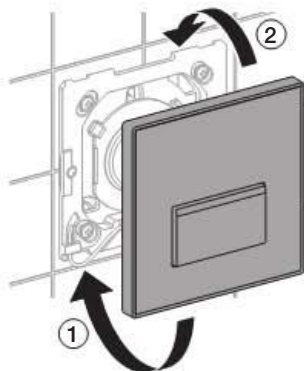

5

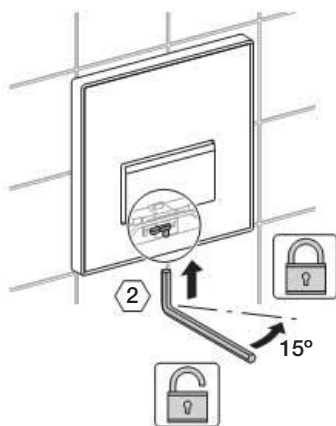

Tekniska data

HyTouch urinalstyrning pneumatik

Flödesnivå vid 1 bar	0,3 / 0,24 (med flödesbegränsare) l/s
Provtryck vatten	16 bar
Provtryck luft/inert gas	3 bar
Manövreringskraft	< 12 N
Spolningstidsintervall	4 / 8 / 12 s
Luftfuktighet	< 100 % relativ
Driftstryck	1 - 8 bar
Max. vattentemperatur	30 °C

SE

Yleisohjeita

Käyttöohje

Säilytä käyttöohje ja anna se tarvittaessa ammattilaisen käyttöön.

Käyttö, huolto

Käyttäjä saa suorittaa vain tässä käyttöohjeessa mainittuja huoltotoita.

Huolto

Muita huoltotoita saavat suorittaa vain ammattilaiset. Epäasianmukaiset työt voivat johtaa onnettomuuksiin, esinevahinkoihin ja käyttöhäiriöihin.





Kohderyhmä

Tämä asiakirja on tarkoitettu EN EC 62079:2001:n mukaisille ammattilaisille.

Määräysten mukainen käyttö

HyTouch urinali huuhtelulaitteet on tarkoitettu posliinien huuhtelemiseen. Käyttötarkoituksen vastainen käyttö vapauttaa takuu- ja vastuuvaatimuksista henkilö- ja omaisuusvahinkojen yhteydessä.

Merkkien selitykset

Symboli	Merkitys
	HUOMIO Viittaa mahdolliseen vaaratilanteeseen, jossa lievät tai hieman vakavammat henkilö- tai omaisuusvahingot ovat mahdollisia.
	Käytä voitelurasvaa!
	Käyttövesi on pois päältä
	Käyttövesi on päällä

Yhteydenotto

Jos sinulla on kysymyksiä tai ongelmia, ota yhteyttä vastaavaan Geberitin jakeluyhtiöön tai katso www.geberit.com.

Rakenne

HyTouch pneumaattinen urinali huuhtelulaite

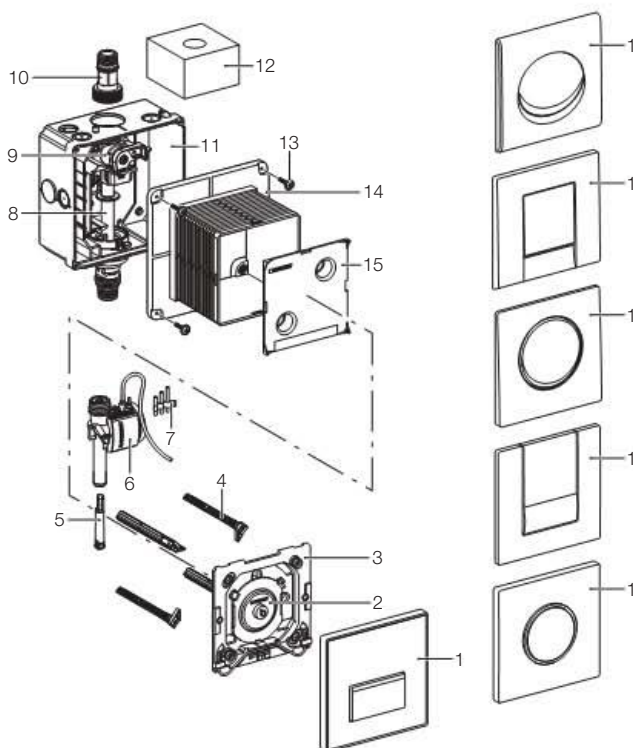

- 1 Huuhtelulevy
- 2 Paineilmapainike
- 3 Asennuskehys
- 4 Etäisyyspultti
- 5 Virtauksenrajoitin
- 6 Pneumaattinen venttiili
- 7 Suutinsarja
- 8 Suojaputki
- 9 Sulkuventtiili, jossa kuristus
- 10 Kytkäntäiliin
- 11 Sisäänrakennuskotelo
- 12 Suojaava sieni
- 13 Asennusruuvit
- 14 Suojakansi
- 15 Suojahattu

Huolto

Huoltovälit

Suorita seuraavat huoltotoimet tarvittaessa, kuitenkin vähintään seuraavasti:

- Huuhtelulevyn pinnan puhdistus - viikon välein, käyttäjä suorittaa
- Korisuodattimen puhdistus - 2 vuoden välein, ammattilainen suorittaa

Huoltotyöt

Huuhtelulevyn puhdistus



HUOMIO

Voimakkaat ja hankaavat puhdistusaineet voivat vahingoittaa pintaa.

- ▶ Älä käytä kloori- tai happopitoisia, hiovia tai syövyttäviä puhdistusaineita, vaan ainoastaan mietoja puhdistusaineita ja vettä



Valituksia, joiden syynä on epäasianmukainen käsittely puhdistusaineilla, ei voida ottaa huomioon.

FI

Korisuodattimen puhdistus tai vaihto



Huolto

Vianmääritys

Ongelma	Mahdollinen aiheuttaja	Korjaus
Vettä ei tule	Sulkuventtiili on kiinni Korisuodatin on tukossa tai likaantunut	Avaa sulkuventtiili Puhdista tai vaihda korisuodatin • Katso "Huolto, korisuodattimen puhdistus tai vaihto"
	Vesijohdossa ei painetta	Tarkasta vesipaine • Palauta vesipaine
	Pneumatiikkaletkun muhviiliitos paineilmapainikkeen ja pneumaattisen venttiilin välillä on irronnut	Kiinnitä pneumatiikkaletkun muhviiliitos
	Pneumatiikkaletku on taivuttunut tai katkennut	Vaihda viallinen pneumatiikkaletku
	Pneumaattinen venttiili on epäkunnossa	Vaihda pneumaattinen venttiili uuteen • Katso "Huolto, pneumaattisen venttiilin vaihto"
Jatkuva virtaus (veden tulo ei pysähdy)	Pneumaattinen venttiili on epäkunnossa	Vaihda pneumaattinen venttiili uuteen • Katso "Huolto, pneumaattisen venttiilin vaihto"
Posliinin huuhtelu ei ole riittävä	Kuristus avautuu liian vähän	Avaa kuristus
Huuhteluvesi roiskuu posliinista	Liian suuri virtausmäärä	Asenna virtauksenrajoitin • Virtauksenrajoitin on saatavissa lisätarvikkeena (242.484.00.1)

Huoltotoimet

Tässä huolto-ohjeessa esitetään huuhtelulaite, jossa on pystysuora vesijohto (A). Tässä ei esitetä huuhtelulaitetta, jossa on vaakasuora vesijohto (B), mutta huoltotoimet ovat samat.

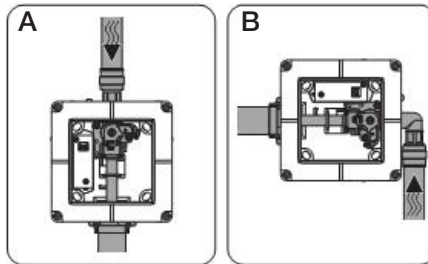

Tässä kuvataan seuraavat huoltotoimet:

- Huuhtelulevyn ja asennuskehiksen irrotus
- Pneumaattisen venttiilin vaihto
- Säätöruuvien vaihto
- Huuhteluputkiston huultiviesteen vaihto
- Asennuskehiksen ja huuhtelulevyn asennus

Huuhtelulevyn ja asennuskehiksen irrotus

1

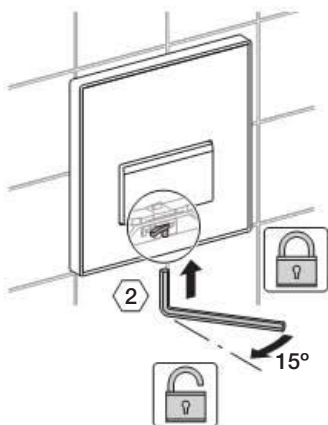

2

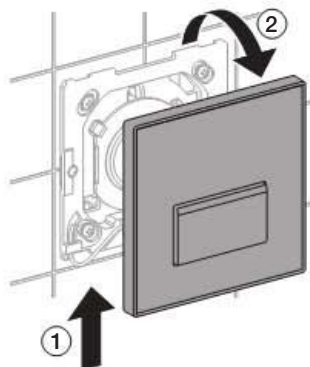

3

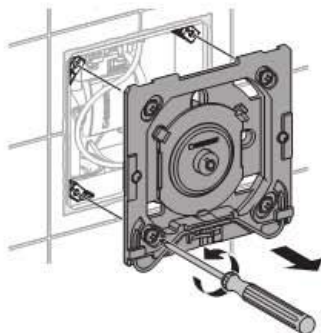

4

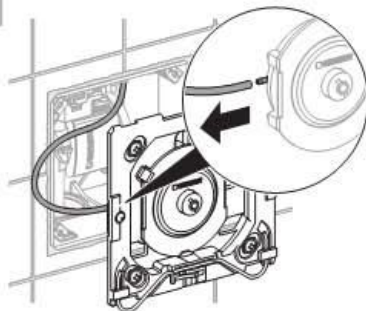

Pneumaattisen venttiilin vaihto

Edellytykset

Huuhtelulevy ja asennuskehys on irrotettu.

Katso "Huolto, huuhtelulevyn ja asennuskehiksen irrotus".

FI

1

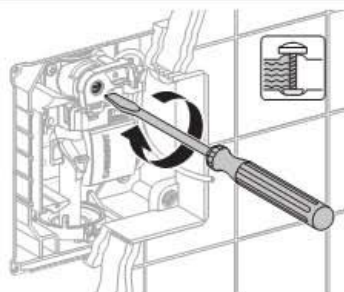

2

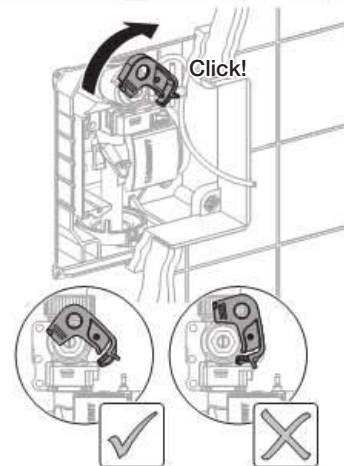

Huolto

3

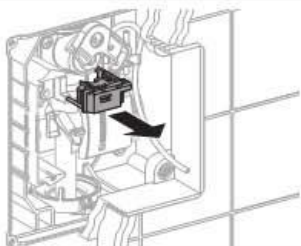

4

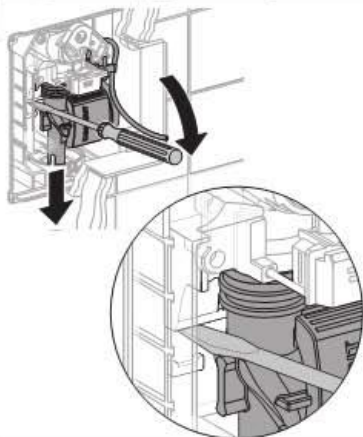

5

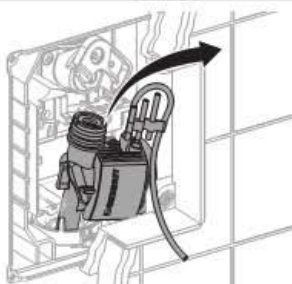

6

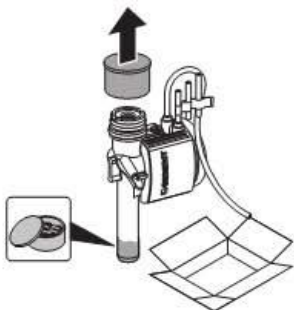

7

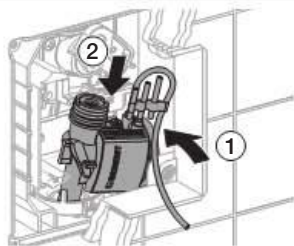

8

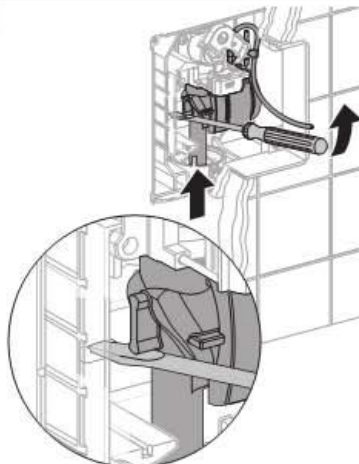

9

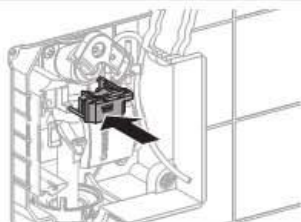

10

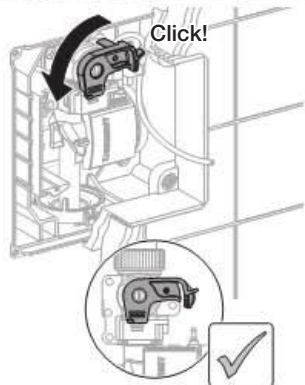

Säätöruuvin vaihto

Edellytykset

Huhtelulevy ja asennuskehys on irrotettu.
Katso "Huolto, huhtelulevyn ja asennuskehysten irrotus".

1

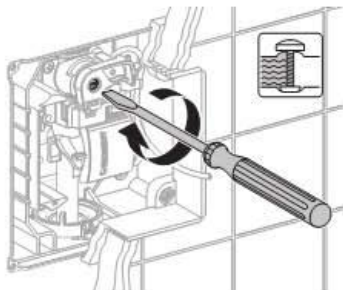

2 Sulje pääsulkuventtiili.

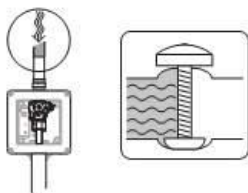

3

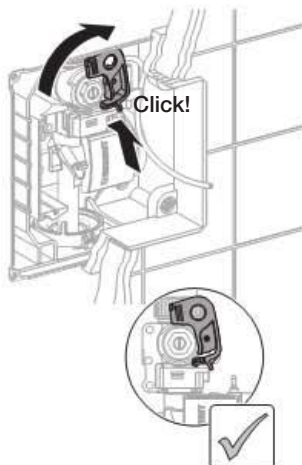

4

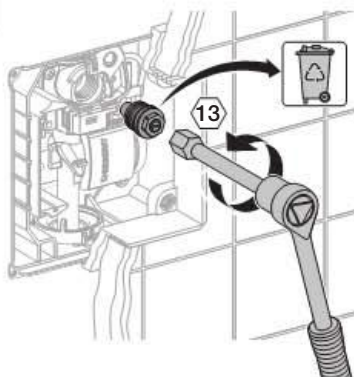

5

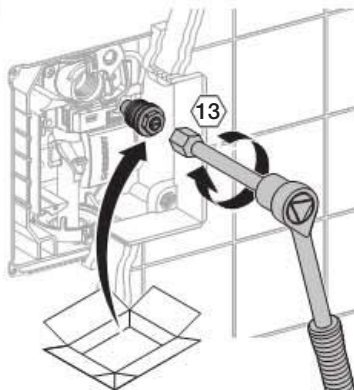

FI

6

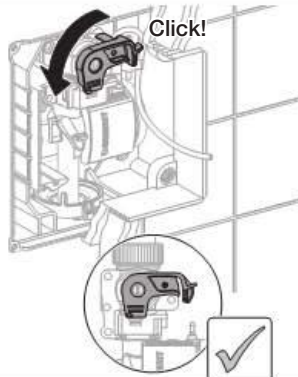

7

Avaa pääsulkuventtiili.



Huuhteluputkiston huultiivisteiden vaihto

Edellytykset

Huuhtelulevy ja asennuskehys on irrotettu.
Katso "Huolto, huuhtelulevyn ja asennuskehksen irrotus".

1

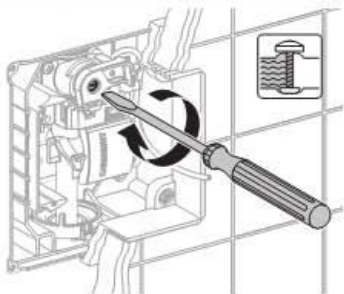

2

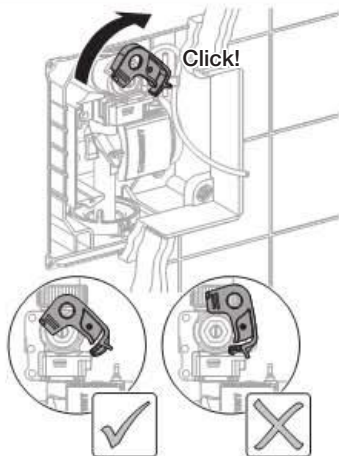

3

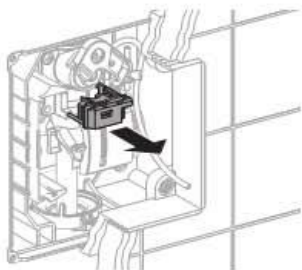

4

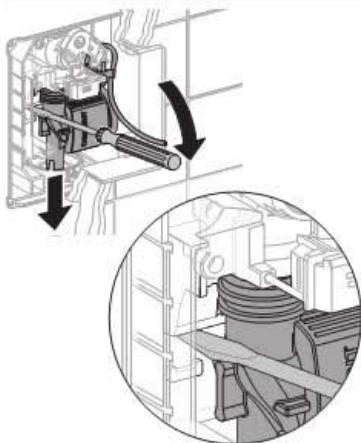

5

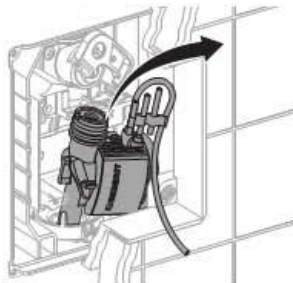

6

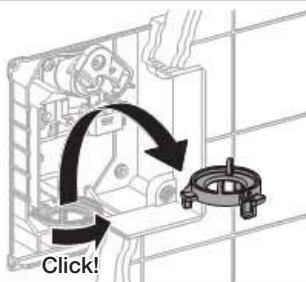

7

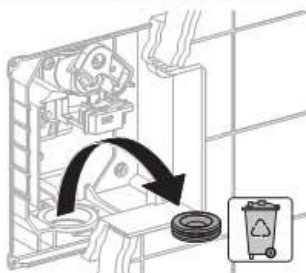

8



9

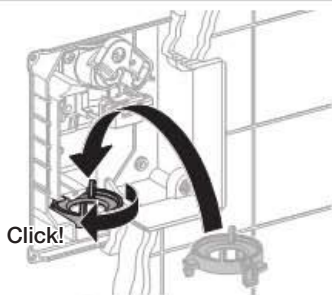

10

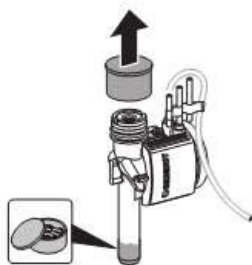

11

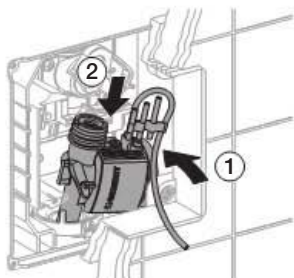

12

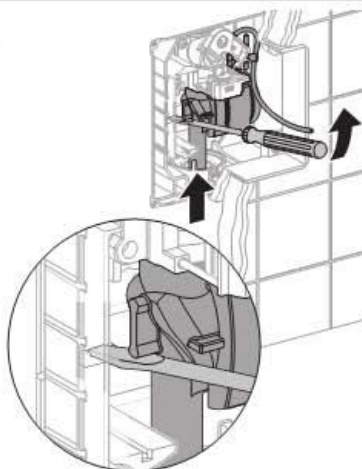

FI

13

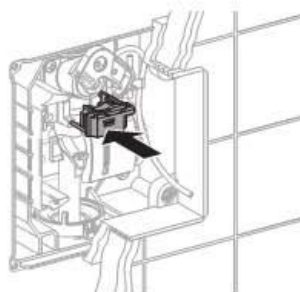

14

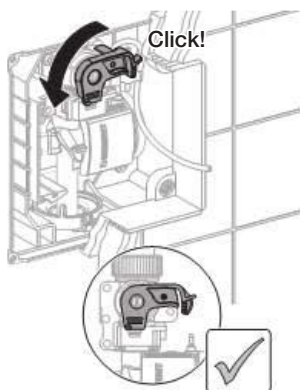

Asennuskehysten ja huuhtelulevyn asennus

1

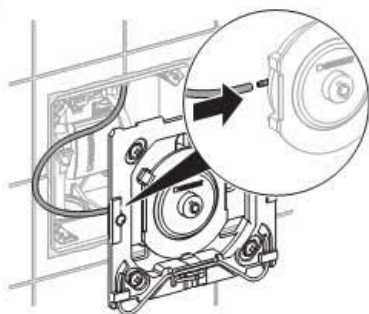

2

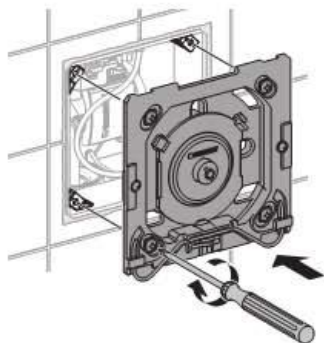

3

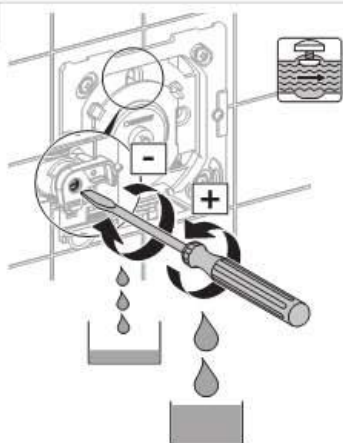

4

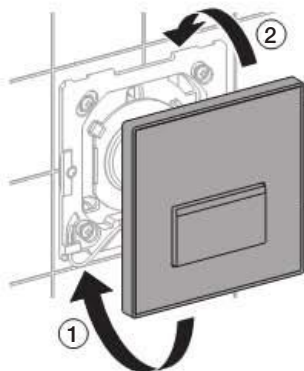

5

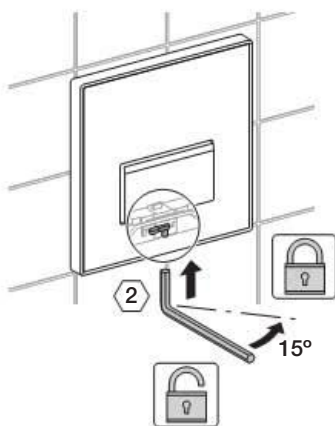

Tekniset tiedot

HyTouch pneumaattinen urinali huuhtelulaite

Virtausmäärä, kun paine on 1 bar	0,3 / 0,24 (virtauksenrajoitin) l/s
Veden koepaine	16 bar
Ilman / inertin kaasun koepaine	3 bar
Painikevastus	< 12 N
Huuhteluajan säätöalue	4 / 8 / 12 s
Kosteus	< 100 % suhteellinen
Käyttöpainealue	1 - 8 bar
Veden lämpötila maks.	30 °C

FI

Almennar upplýsingar

Notkunarleiðbeiningarnar Geymið notkunarleiðbeiningarnar og afhendið þær fagaðilum eftir þörfum.

Notkun, viðhald Rekstraraðilar mega aðeins annast viðhald sjálfir að því marki sem lýst er í þessum leiðbeiningum.

Þjónusta Eingöngu fagaðilum er heimilt að annast þjónustu. Ef ekki er unnið með réttum hætti getur það valdið slysum, tjóni og bilunum.





Markhópur

Þetta rit er ætlað fagfólki samkvæmt EN IEC 62079:2001.

Rétt notkun

HyTouch þvagskálástýringarnar eru ætlaðar fyrir skolon þvagskála. Við ranga notkun fellur ábyrgð vegna slysa eða tjóns úr gildi.

Skýringar á táknum

Tákn	Merking
 VARÚÐ	Bendir á mögulega hættu sem getur leitt til smávægilegra áverka, meðaláverka eða tjóns.
	Notið smurfeiti!
	Skrúfað hefur verið fyrir vatnið
	Skrúfað hefur verið frá vatninu

IS

Nánari upplýsingar

Nálgast má frekari upplýsingar eða óska eftir aðstoð hjá viðkomandi söluaðila Geberit eða á www.geberit.com.

Samsetning

Loftknúin HyTouch þvagskálastýring

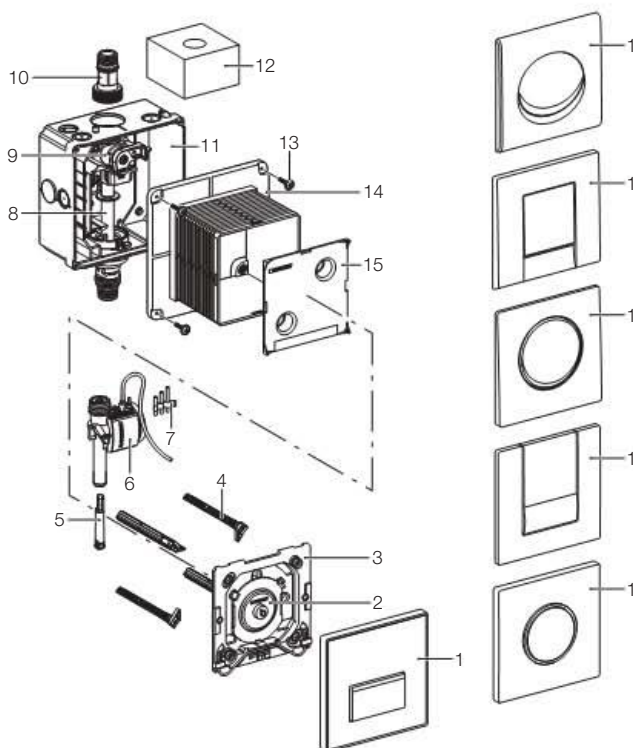

- 1 Stjórnplata
- 2 Lofttrofi
- 3 Festirrammi
- 4 Milliboltar
- 5 Flæðistakmarkari
- 6 Loftventill
- 7 Túðuset
- 8 Lagnarör
- 9 Einstreymisloki með spjaldi
- 10 Tenginippill
- 11 Innfellt hús
- 12 Hlíðarsvampur
- 13 Festiskrúfur
- 14 Hlíf
- 15 Lok á hlíf

Viðhald

Viðhaldstímabil

Eftirfarandi viðhaldsvinna skal fara fram eftir þörfum, þó ekki sjaldnar en með því millibili sem hér kemur fram:

- Þrif á stjórnplötu – vikulega, af rekstraraðila
- Þrif á körfusíu – á 2 ára fresti, af fagaðila

Viðhaldsvinna

Þrif á stjórnplötu

VARÚÐ
Gróf og ætandi hreinsiefni geta valdið skemmdum á yfirborðinu.

- Notið ekki efni sem eru slípanði, ertandi eða innihalda klór eða síyru, heldur eingöngu mild hreinsiefni og vatn

i Engin ábyrgð er tekin á skemmdum sem hljótask af rangri meðhöndlun með hreinsiefnum.

Körfusían hreinsuð eða skipt um hana



IS

Þjónusta

Þjónusta

Bilanaleit

Vandamál	Möguleg orsök	Ráðstafanir
Ekkert vatn rennur	Lokað er fyrir aðstreymi vatns Körfusían er stífluð eða óhrein	Opnið fyrir aðstreymi vatns Hreinsið körfusíuna eða skiptið um hana <ul style="list-style-type: none">• Sjá „Viðhald, Körfusían hreinsuð eða skipt um hana“
	Enginn þrýstingur í vatnslögnum	Athugið vatnsþrýstinginn <ul style="list-style-type: none">• Komið vatnsþrýstingi aftur á
	Loftslangan milli þrýstiloftshnappsins og loftventilsins hefur verið aftengd	Tengið loftslönguna
	Brotið er upp á loftslönguna eða rifa á henni	Skiptið um skemmdu loftslönguna
	Loftventillinn er í ólagi	Skiptið um loftventilinn <ul style="list-style-type: none">• Sjá „Þjónusta, Skipt um loftventil“
Vatnsrennslið stöðvast ekki	Loftventillinn er í ólagi	Skiptið um loftventilinn <ul style="list-style-type: none">• Sjá „Þjónusta, Skipt um loftventil“
Ekki er skolað nægilega vel úr þvagskálinni	Spjaldið opnast ekki nógu mikið	Opnið spjaldið
Skolvatn skvettist úr þvagskálinni	Of mikið flæði	Setjið upp flæðistakmarkara <ul style="list-style-type: none">• Flæðistakmarkarinn er fánlegur sem aukabúnaður (242.484.00.1)

Þjónustuvinna

Þessar þjónustuleiðbeiningar sýna stýringu með lóðréttri vatnslögn (A). Stýring með láréttri vatnslögn (B) er ekki sýnd, en þjónustuvinnan er hin sama.

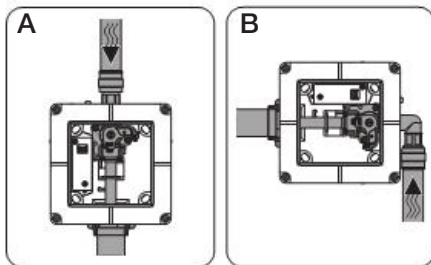

Eftirfarandi þjónustuvinnu er lýst hér:

- Stjórnplata og festirami tekin af
- Skipt um loftventilinn
- Skipt um spjaldskrúfu
- Skipt um þéttingu skollagnar
- Festirami og stjórnplata sett á

Stjórnplata og festirammur tekin af

1

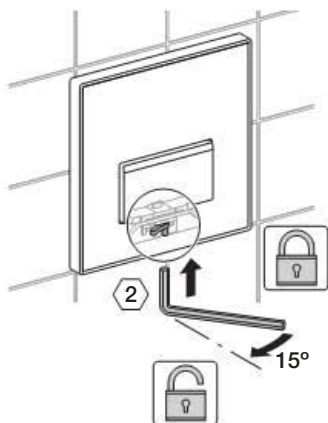

2

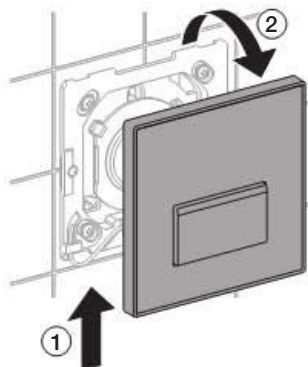

3

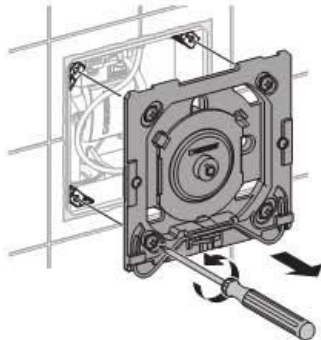

4

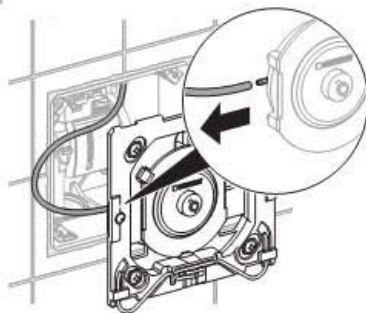

Skipt um loftventilinn

Skilyrði

Stjórnplata og festirammur hafa verið tekin af.
Sjá „Þjónusta, Stjórnplata og festirammur tekin af“.

1

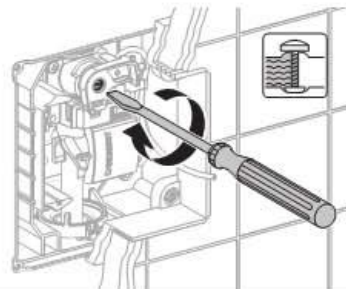

2

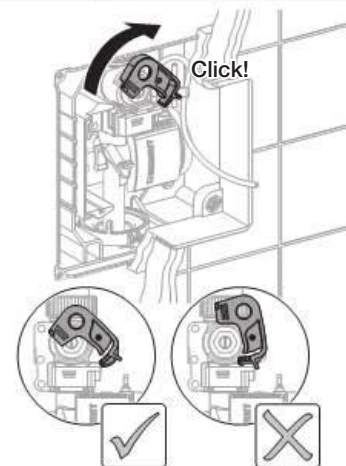

Pjónusta

3

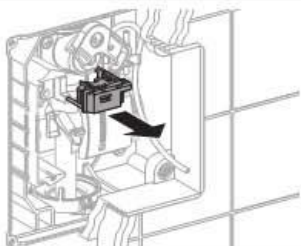

4

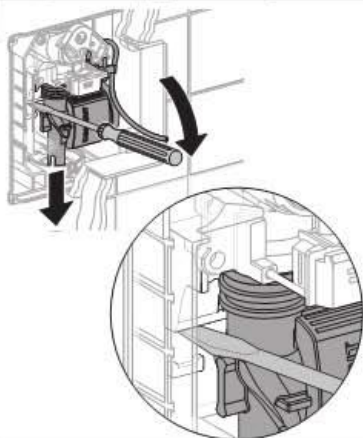

5

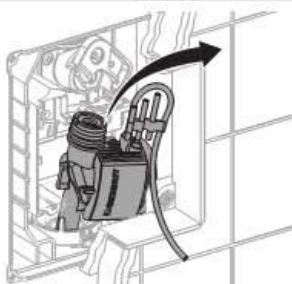

6

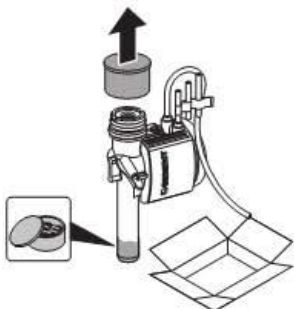

7

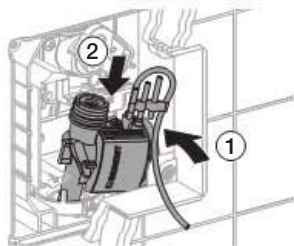

8

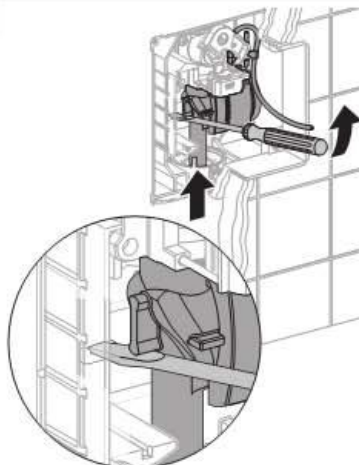

9

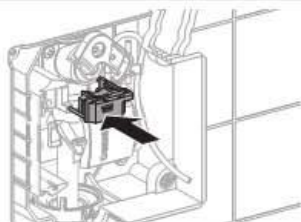

10

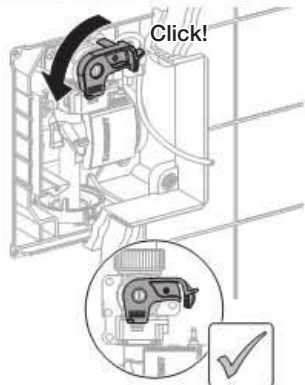

Skipt um spjaldsknúfu**Skilyrði**

Stjórnplata og festirammur hafa verið tekin af.

Sjá „Þjónusta, Stjórnplata og festirammur tekin af“.

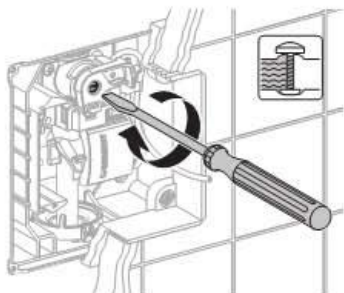
1**2**

Lokið fyrir aðstreymi vatns.

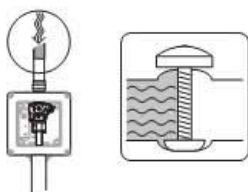
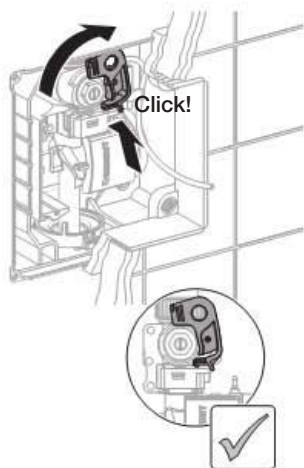
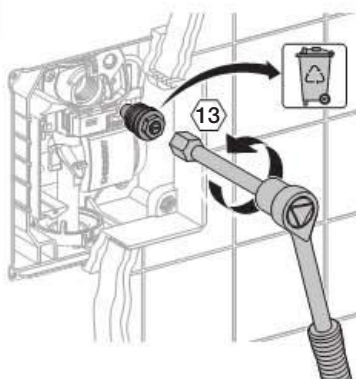
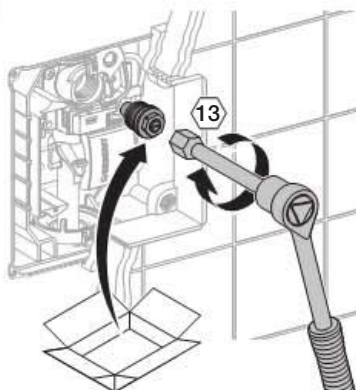
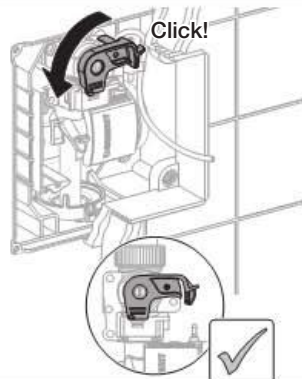
**3****4****5****6****7**

Opnið fyrir aðstreymi vatns.



Skipt um þéttingu skollagnar

Skilyrði

Stjórnplata og festirammur hafa verið tekin af.
Sjá „Þjónusta, Stjórnplata og festirammur tekin af“.

1

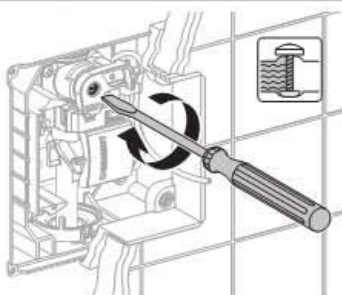

2

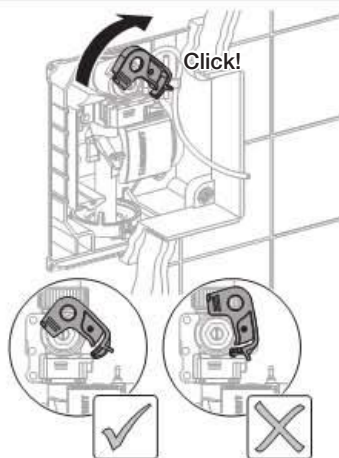

3

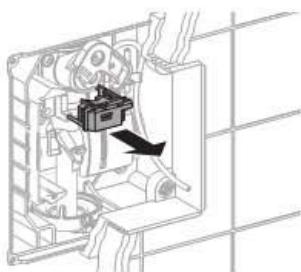

4

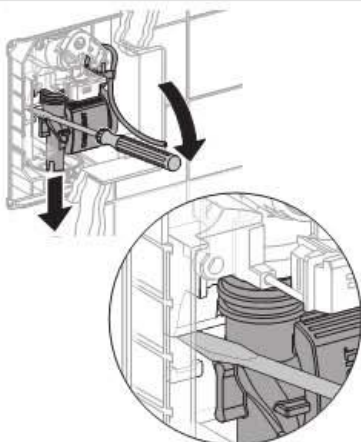

5

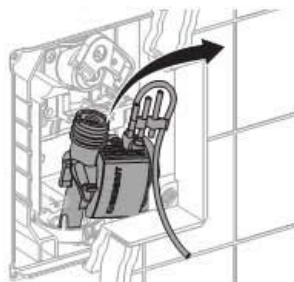

6

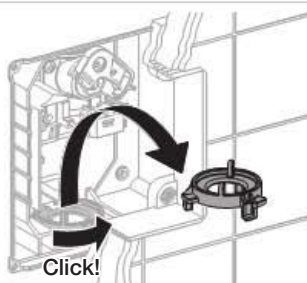

7

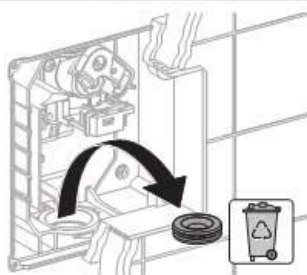

8



9

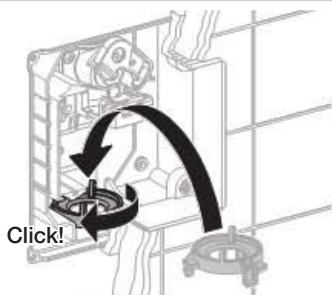

10

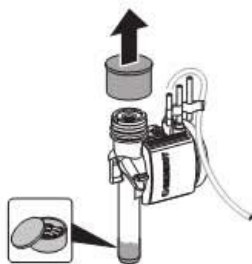

11

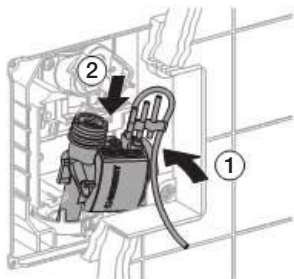

12

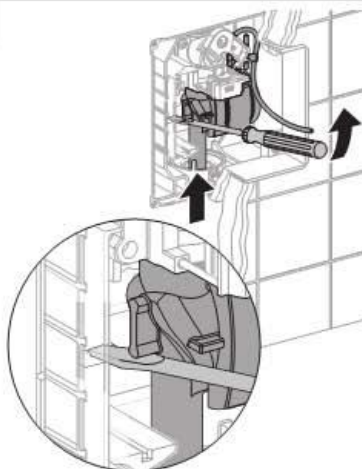

13

IS

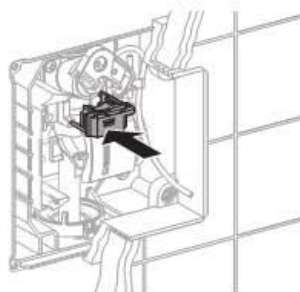

14

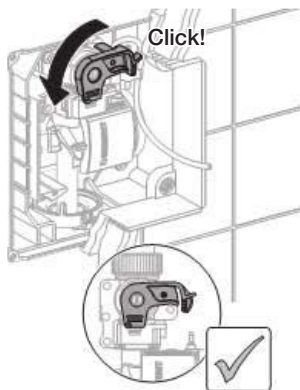

Festirami og stjórnplata sett á

1

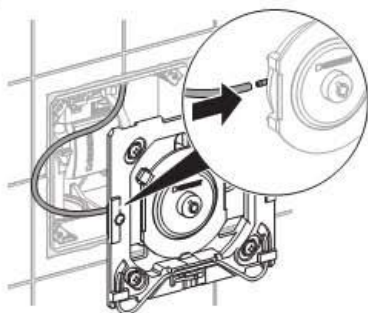

2

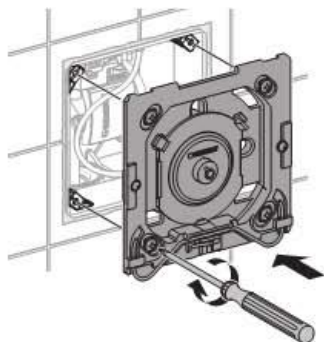

3

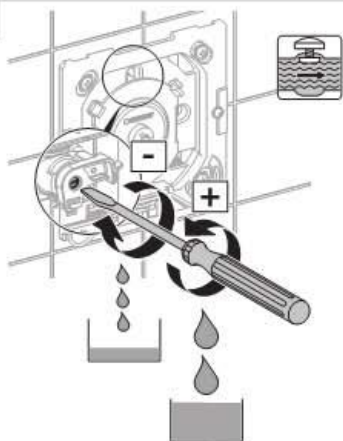

4

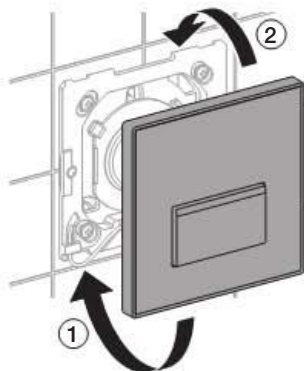

5

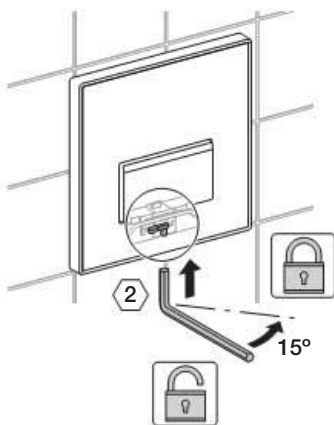

Tæknilegar upplýsingar

Loftknúin HyTouch þvagskálástýring

Gegnumstreymi við 1 bar	0,3 / 0,24 (með flæðistakmarkara)	l/s
Prófunarþrýstingur vatns		16 bar
Prófunarþrýstingur lofts / eðalgass		3 bar
Afl við beitingu		< 12 N
Stillisvið skolonartíma		4 / 8 / 12 s
Rakastig		< 100 %
Þrýstisvið við notkun		1 - 8 bar
Hámarkshitastig vatns við notkun		30 °C

IS

Informacje ogólne

Instrukcja obsługi	Instrukcję obsługi należy zachować i w razie potrzeby udostępnić odpowiedniemu specjalście.
Eksploatacja, konserwacja	Użytkownik może wykonywać tylko prace konserwacyjne, które zostały opisane w niniejszej instrukcji obsługi.
Serwis	Prace serwisowe mogą być wykonywane tylko przez odpowiedniego specjalistę. Nieprawidłowo przeprowadzone prace mogą doprowadzić do wypadków, uszkodzeń lub zakłóceń w funkcjonowaniu urządzenia.





Przeznaczenie

Zgodnie z normą EN IEC 62079:2001 dokument ten jest skierowany do osób wykwalifikowanych.

Użytkowanie zgodne z przeznaczeniem

Zawory spłukujące do pisuarów HyTouch są przeznaczone do spłukiwania pisuarów. W przypadku użytkowania niezgodnego z przeznaczeniem roszczenia z tytułu gwarancji i odpowiedzialności cywilnej w przypadku szkód na zdrowiu i życiu osób oraz szkód materialnych nie mają zastosowania.

Objaśnienie symboli

Symbol	Znaczenie
 UWAGA	Wskazuje na potencjalnie niebezpieczną sytuację, która może powodować lekkie lub średnie obrażenia ciała lub szkody materialne.
	Stosować środek smarujący!
	Woda jest odłączona
	Woda jest podłączona

Kontakt

W przypadku pytań lub problemów należy skontaktować się z właściwym dystrybutorem firmy Geberit lub wejść na stronę www.geberit.com.

Budowa

Układ pneumatyczny zaworu spłukującego do pisuarów HyTouch

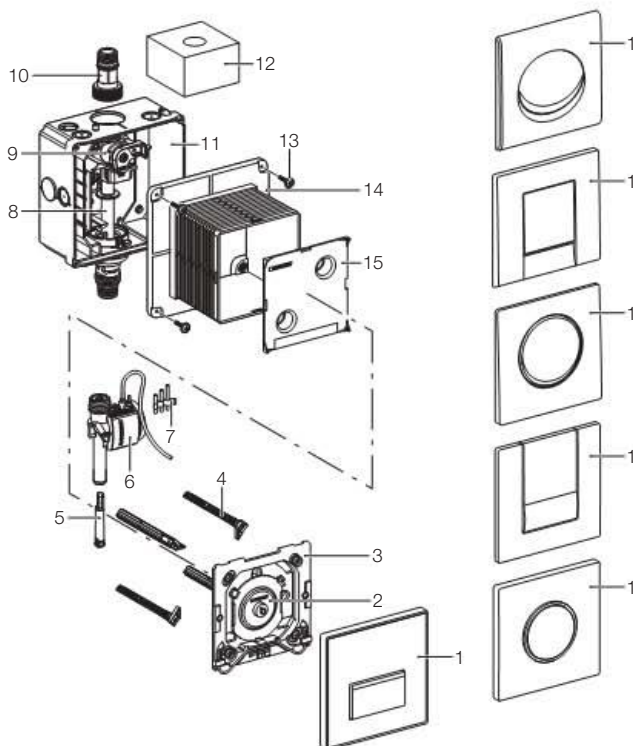

- 1 Przycisk uruchamiający
- 2 Przycisk pneumatyczny
- 3 Ramka montażowa
- 4 Bolce dystansowe
- 5 Ogranicznik przepływu
- 6 Zawór pneumatyczny
- 7 Zestaw dysz
- 8 Rura osłonowa
- 9 Zawór odcinający z dławką
- 10 Króciec przyłączeniowy
- 11 Obudowa podtynkowa
- 12 Kostka ochronna
- 13 Śruby mocujące
- 14 Osłona skrzynki montażowej
- 15 Pokrywa ochronna

Konservacja

Częstotliwość konserwacji

Następujące prace konserwacyjne należy wykonywać w razie potrzeby, najpóźniej jednak w podanych terminach:

- Czyszczenie powierzchni przycisku uruchamiającego - raz w tygodniu, przez użytkownika
- Czyszczenie filtra koszykowego - raz na dwa lata, przez specjalistę

Prace konserwacyjne

Czyszczenie przycisku uruchamiającego



UWAGA

Żrące i szorujące środki czyszczące mogą uszkodzić powierzchnię.

- ▶ Nie używać środków czyszczących z zawartością chloru lub kwasu, środków do polerowania lub żrących, stosować wyłącznie łagodne środki czyszczące i wodę.



Reklamacje spowodowane niewłaściwą pielęgnacją i stosowaniem nieodpowiednich środków czyszczących nie będą uznawane.

Czyszczenie lub wymiana filtra koszykowego



Serwis

Usterki

Problem	Możliwa przyczyna	Środek zaradczy
Woda nie płynie	Zamknięty dopływ wody	Otworzyć dopływ wody
	Filtr koszykowy jest zatkany lub zanieczyszczony	Wyczyścić lub wymienić filtr koszykowy • Patrz "Konserwacja, czyszczenie lub wymiana filtra koszykowego"
	Brak ciśnienia w sieci wodociągowej	Sprawdzić ciśnienie wody • Przywrócić ciśnienie wody
	Połączenie wtykowe wężyka pneumatycznego między przyciskiem a zaworem pneumatycznym jest rozłączone	Podłączyć połączenie wtykowe wężyka pneumatycznego
	Wężyk pneumatyczny jest zagięty lub pęknięty	Wymienić uszkodzony wężyk pneumatyczny
Zawór pneumatyczny jest uszkodzony		Wymienić zawór pneumatyczny • Patrz "Serwis, wymiana zaworu pneumatycznego"
	Zawór pneumatyczny jest uszkodzony	Wymienić zawór pneumatyczny • Patrz "Serwis, wymiana zaworu pneumatycznego"
Wyływ ciągły (woda nie przestaje płynąć)	Zawór pneumatyczny jest uszkodzony	Wymienić zawór pneumatyczny • Patrz "Serwis, wymiana zaworu pneumatycznego"
Pisuar jest niewystarczająco splukiwany	Dławik jest za mało otwarty	Otworzyć dławik
Woda splukująca przyska z pisuaru	Za duży przepływ	Zamontować ogranicznik przepływu • Ogranicznik przepływu jest dostępny jako wyposażenie dodatkowe (242.484.00.1)

Prace serwisowe

Niniejsza instrukcja serwisowa przedstawia urządzenie sterujące z pionowym prowadzeniem wody (A). Urządzenie sterujące z poziomym prowadzeniem wody (B) nie zostało przedstawione, prace serwisowe w obydwu przypadkach są jednak identyczne.

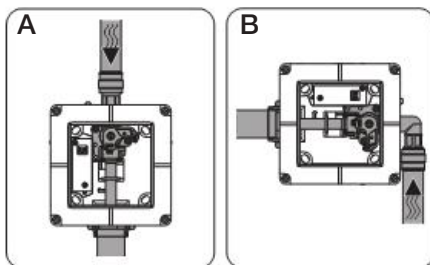

Opisane zostały tu następujące prace serwisowe:

- Demontaż przycisku uruchamiającego i ramki montażowej
- Wymiana zaworu pneumatycznego
- Wymiana śruby dławiącej
- Wymiana uszczelki wargowej przewodu splukującego
- Montaż ramki montażowej i przycisku uruchamiającego

Demontaż przycisku uruchamiającego i ramki montażowej

1

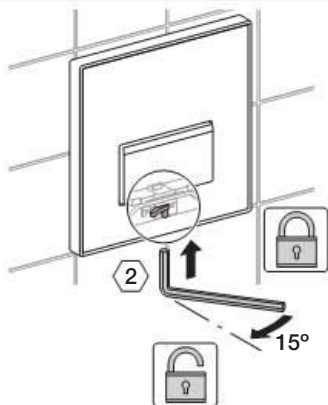

2

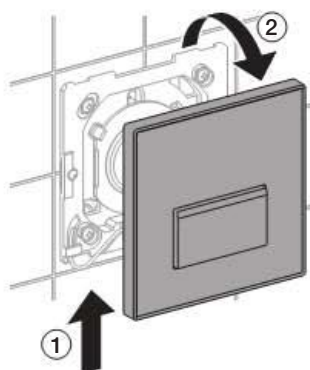

3

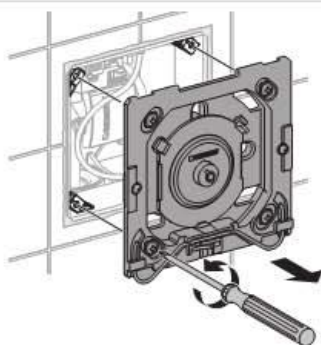

4

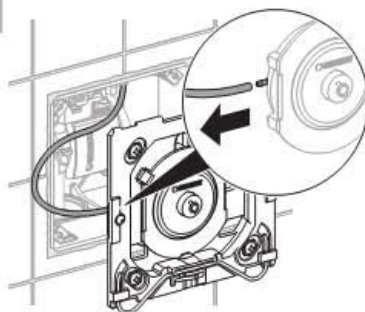

Wymiana zaworu pneumatycznego

Warunki

Przycisk uruchamiający i ramka montażowa są zdemontowane.

Patrz "Serwis, demontaż przycisku uruchamiającego i ramki montażowej".

1

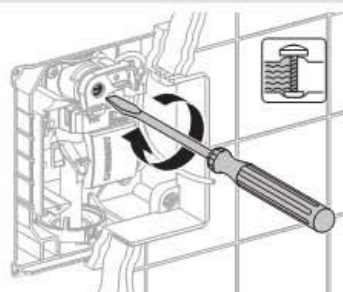

2

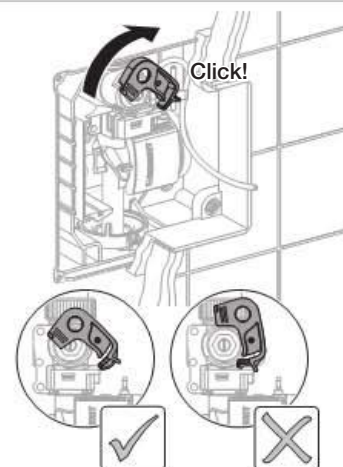

PL

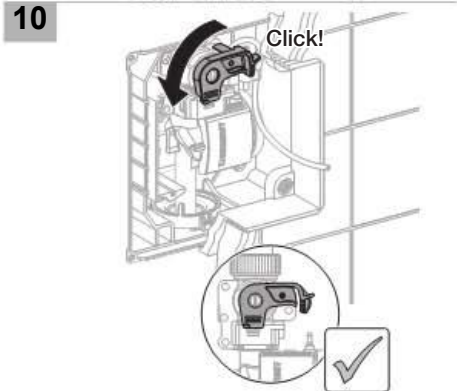
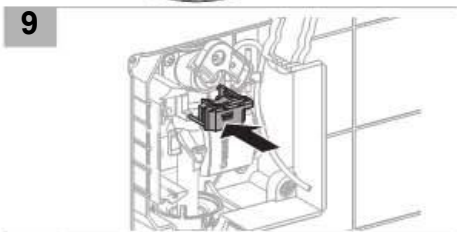
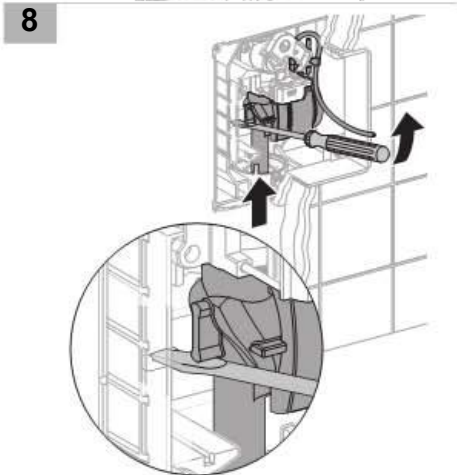
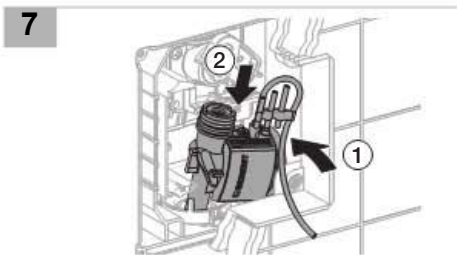
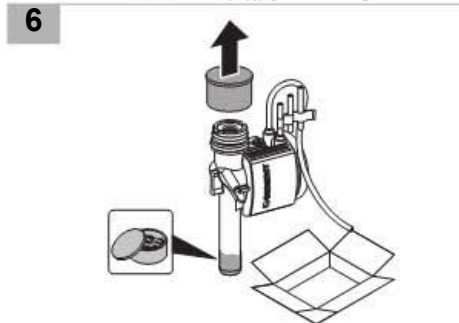
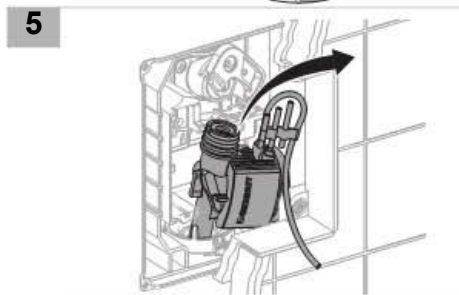
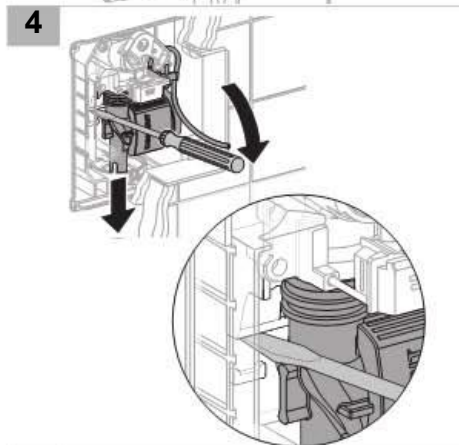
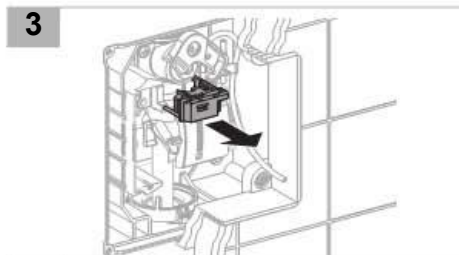

Wymiana śruby dławiącej

Warunki

Przycisk uruchamiający i ramka montażowa są zdemontowane.

Patrz "Serwis, demontaż przycisku uruchamiającego i ramki montażowej".

1

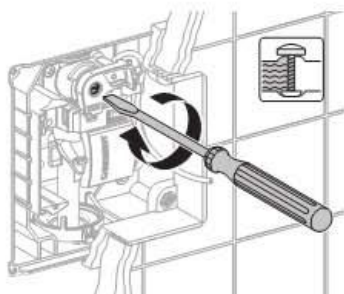

2 Zamknąć główny dopływ wody.

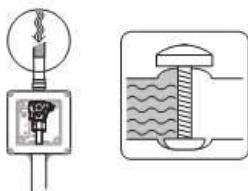

3

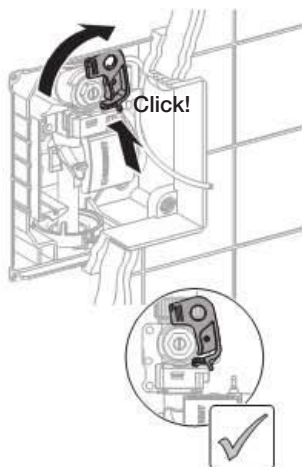

4

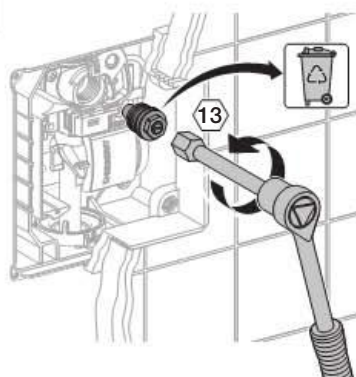

5

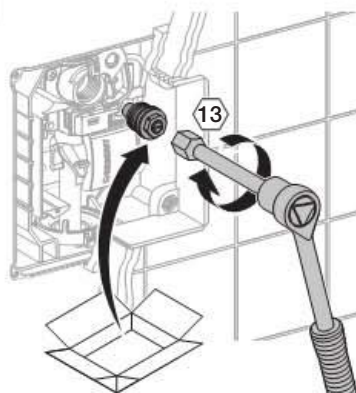

6

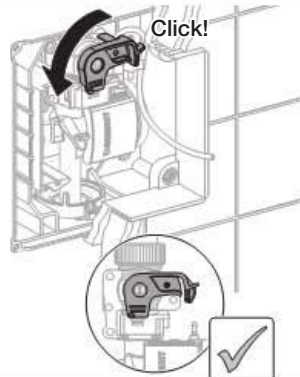

7 Otworzyć główny dopływ wody.



PL

Wymiana uszczelki wargowej przewodu splukującego

Warunki

Przycisk uruchamiający i ramka montażowa są zdemontowane.

Patrz "Serwis, demontaż przycisku uruchamiającego i ramki montażowej".

1

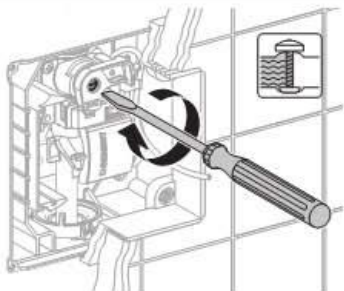

2

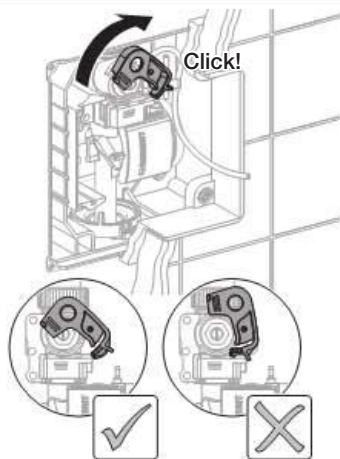

3

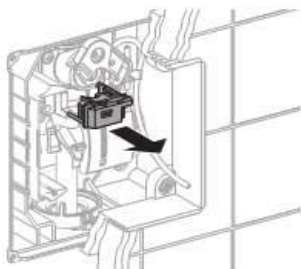

4

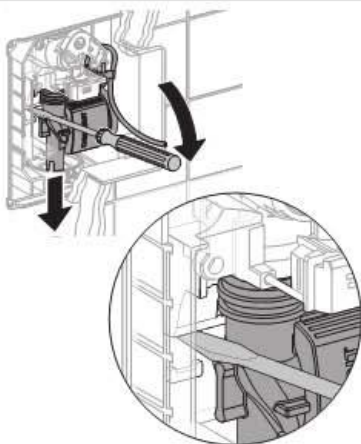

5

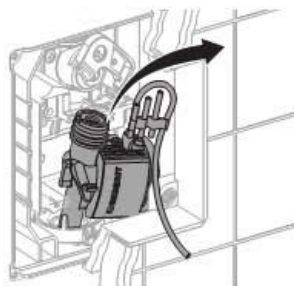

6

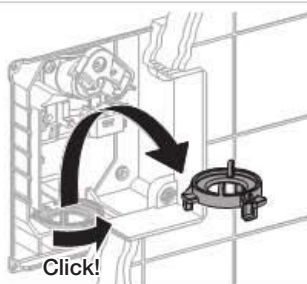

7

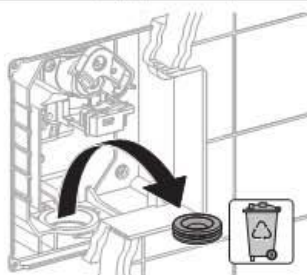

8



9

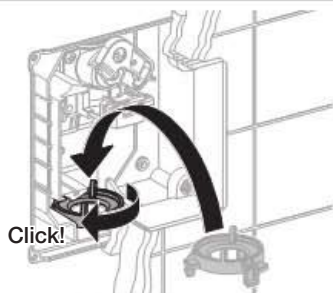

10

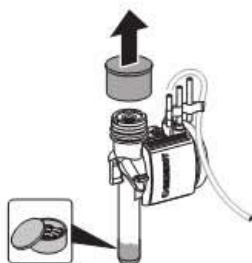

11

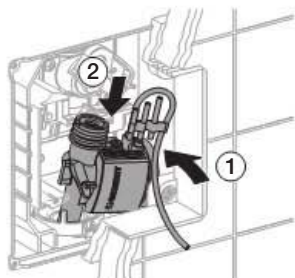

12

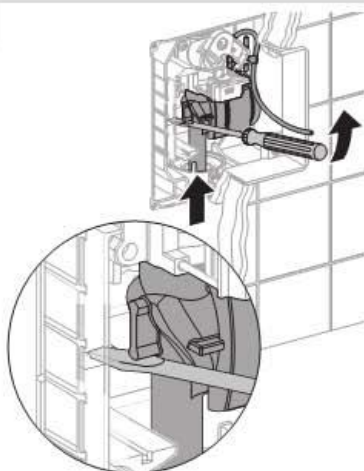

13

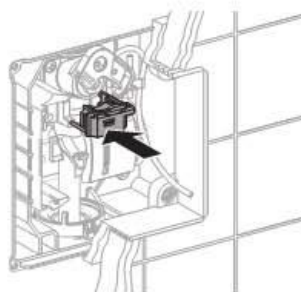

14

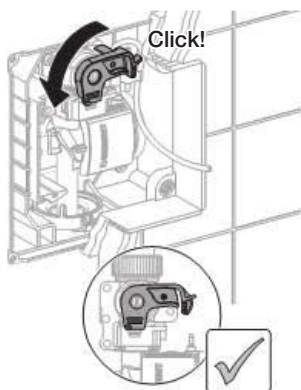

PL

Montaż ramki montażowej i przycisku uruchamiającego

1

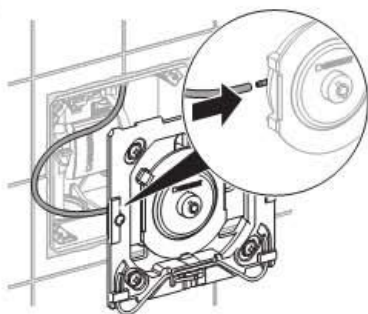

2

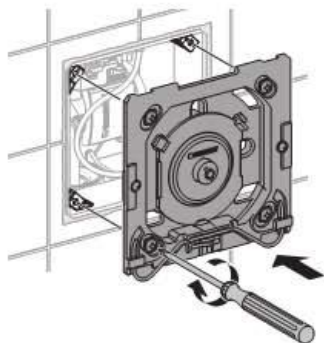

3

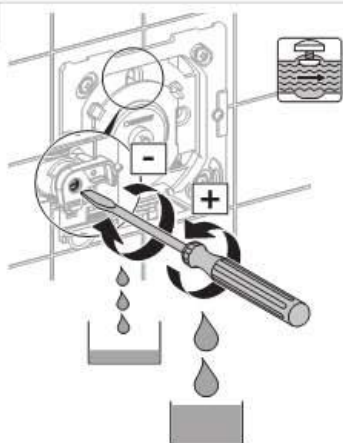

4

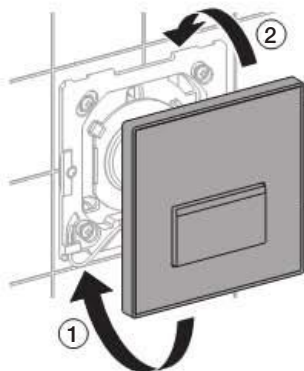

5

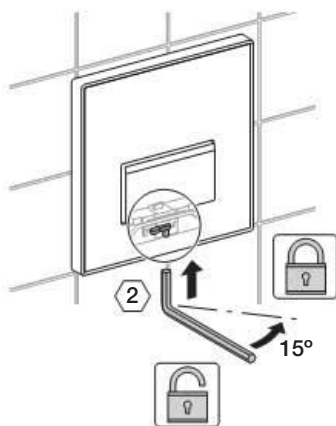

Dane techniczne

Układ pneumatyczny urządzenia sterującego pisuarem HyTouch

Natężenie przepływu przy ciśnieniu 1 bar	0,3/0,24 (z ogranicznikiem przepływu) l/s
Ciśnienie próbne wody	16 bar
Ciśnienie próbne powietrza / gaz obojętny	3 bar
Wymagany nacisk	< 12 N
Zakres ustawień czasu spłukiwania	4 / 8 / 12 s
Wilgotność powietrza	< 100 % względna
Zakres ciśnień	1 - 8 bar
Maks. temperatura wody	30 °C

Általános tudnivalók

Üzemeltetési útmutató	Őrizze meg az üzemeltetési útmutatót, szükség esetén bocsássa azt a szakember rendelkezésére.
Üzemeltetés, karbantartás	Az üzemeltető csak az üzemeltetési útmutatóban meghatározott mértékig végezhet karbantartási munkálatokat.
Szerviz	Szervizmunkákat csak szakember végezhet. A szakszerűtlen munka baleseteket okozhat, anyagi károkhoz és üzemzavarokhoz vezethet.





Célcsoport

Ez a dokumentum az EN IEC 62079:2001 szabvány szerinti szakemberek számára szól.

Rendeltetésszerű használat

A HyTouch vízelvezérlések a vízeldekagylók öblítésére szolgálnak. Nem rendeltetésszerű használat esetén a gyártó nem vállal felelősséget a bekövetkező személyi sérülésekért vagy anyagi károkért és kizárja a garanciális igények érvényesítésének lehetőségét is.

A szimbólumok magyarázata

Szimbólum	A szimbólum jelentése
 VIGYÁZAT	Valamilyen lehetséges vészhelyzetre utal, amelynek következménye könnyű, vagy közepesen súlyos testi sérülés, illetve anyagi kár lehet.
	Használjon gépszírt!
	Vezetékes víz el van zárva
	Vezetékes víz meg van nyitva

HU

Kapcsolat

Kérdések vagy problémák esetén forduljon az illetékes Geberit nagykereskedőhöz, vagy keresse fel a www.geberit.com internetcímet.

Felépítés

HyTouch vízlevezérlés pneumatika

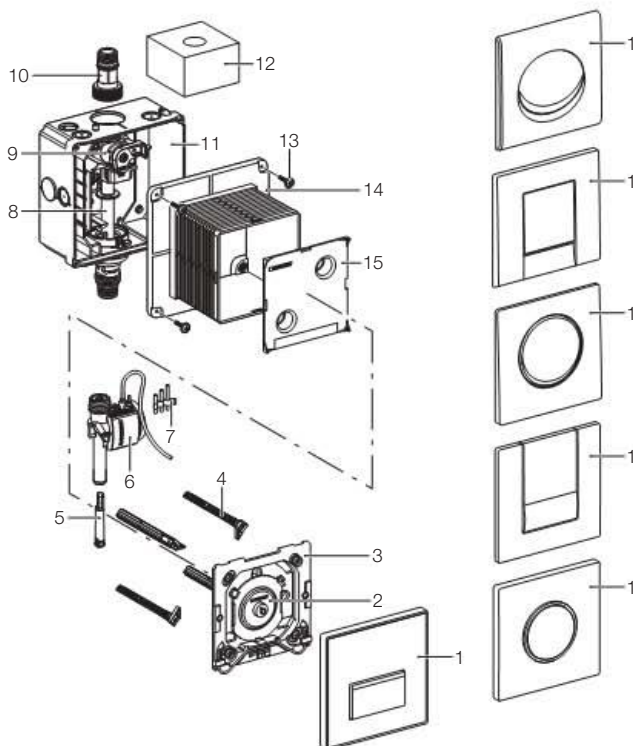

- 1 Működtető nyomólap
- 2 Pneumatikus nyomógomb
- 3 Nyomólap-rögzítő keret
- 4 Távolságtartó rögzítőfül
- 5 Térfogatáram korlátozó
- 6 Pneumatikus szelep
- 7 Fúvóka készlet
- 8 Védőcső
- 9 Elzárószelep fojtószeleppel
- 10 Csatlakozó cső
- 11 Falsík alatti beépítődoboz
- 12 Védőszivacs
- 13 Rögzítőcsavarok
- 14 Törmelék elleni védőfedél
- 15 Építési törmelék elleni fedél

Karbantartás

Karbantartási időközök

Az alábbi karbantartási munkákat szükség esetén, de legkésőbb az előírt időközökként kell elvégezni:

- Működtető nyomólap külső tisztítása - hetente, üzemeltető
- Szűrőkosár tisztítása - két évente, szakember

Karbantartási munkálatok

Működtetőlemez tisztítása



VIGYÁZAT

A korrozív és dörzsölő hatású tisztítószer károsíthatják a felületet.

- ▶ Kizárólag klór és savmentes, nem maró és nem súroló hatású lágy tisztítószer és vizet használjon



Helytelen tisztítószer-használatból eredő reklamációkat nem tudunk elfogadni.

Tisztítsa meg vagy cserélje ki a szűrőkosarat



HU

Szerviz

Hibakeresés

Probléma	Lehetséges ok	Megoldás
Nem folyik víz	A hidegvíz bekötés el van zárva	Nyissa ki a hidegvíz bekötést
	A szűrőkosár eltömődött vagy szennyeződött	Tisztítsa meg vagy cserélje ki a szűrőkosarat • Lásd a "Karbantartás, Szűrőkosár tisztítása vagy cseréje" című fejezetet
	Nincs nyomás a vízhalóza ban	Ellenőrizze a víznyomást • Állítsa helyre a víznyomást
	A légtömítő dugós csatlakozása le van választva a pneumatikus nyomógomb és a pneuma ikaszelep között	Csatlakoztassa a légtömítő dugós csatlakozását
Szivárgó víz (a víz nem zárható el)	A légtömítő megtört vagy kilyukadt	Cserélje ki a hibás légtömítőt
	A pneumatikus szelep hibás	Cserélje ki a pneumatikus szelepet • Lásd a "Szerviz, Pneumatikus szelep cseréje" című fejezetet
	A pneumatikus szelep hibás	Cserélje ki a pneumatikus szelepet • Lásd a "Szerviz, Pneumatikus szelep cseréje" című fejezetet
A vizelde fajansz öblítése elégtelen	A fojtószelep túl kevésbé van megnyitva	Nyissa meg a fojtószelepet
A vizelde fajanszból kifröccsen az öblítővíz	Túl nagy a térfogatáram mennyisége	Szereljen fel térfogatáram korlátozót • A térfogatáram korlátozó kiegészítőként kapható (242.484.00.1)

Szerviz munkálatok

A javítási útmutatóban függőleges vízvezetésű (A) vezérlés látható. A vízszintes vízvezetésű (B) vezérlés nem látható, de az azon végzendő szerviz munkálatok megegyeznek.

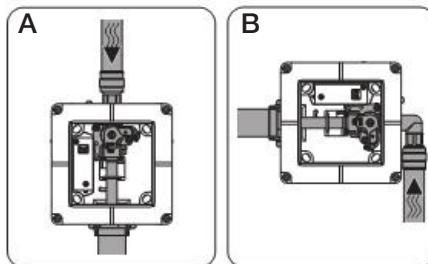

Az alábbi szerviz munkálatok leírása található itt:

- Nyomólap és nyomólap-rögzítő keret leszerelése
- Pneumatikus szelep cseréje
- Szabályozó csavar cseréje
- Öblítővezeték ajakos tömítésének cseréje
- Nyomólap-rögzítő keret és nyomólap felszerelése

Működtetőlemez és rögzítőkeret leszerelése

1

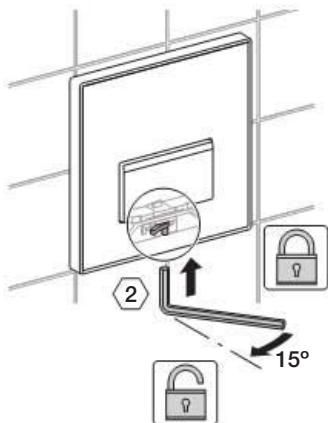

2

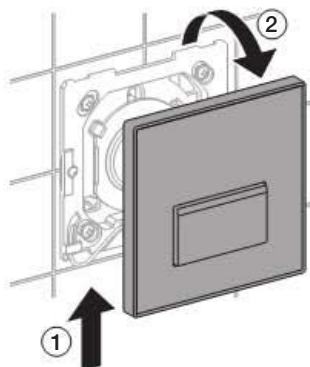

3

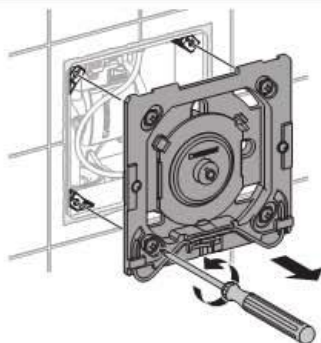

4

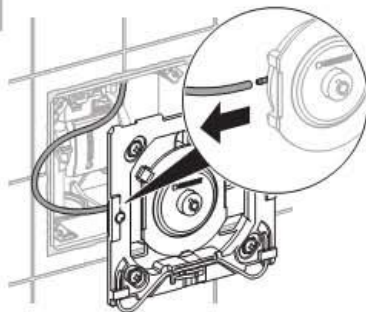

Pneumatikus szelep cseréje

Előfeltételek

Nyomólap és nyomólap-rögzítő keret leszerelve.

Lásd "Szerviz, Nyomólap és nyomólap-rögzítő keret leszerelése".

1

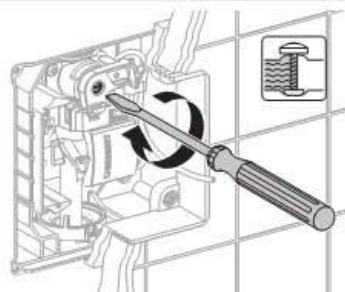

2

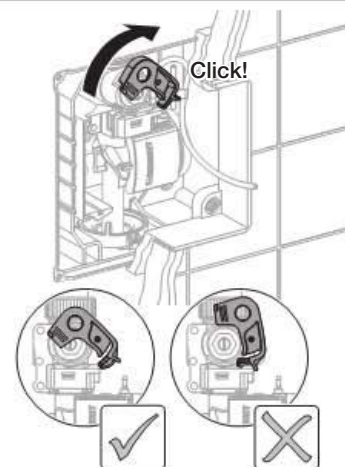

HU

3

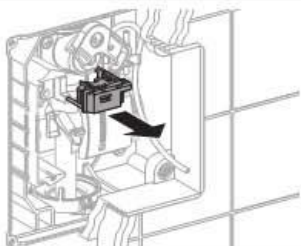

4

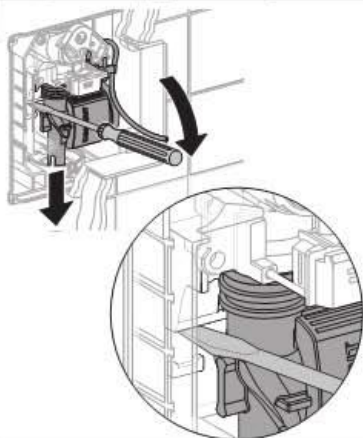

5

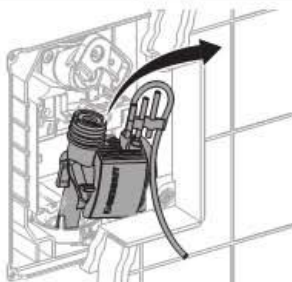

6

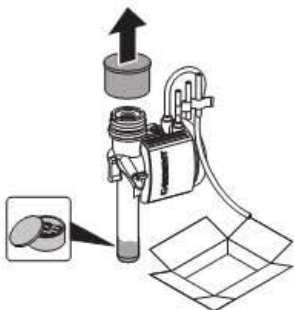

7

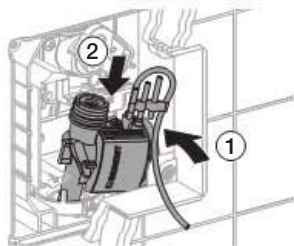

8

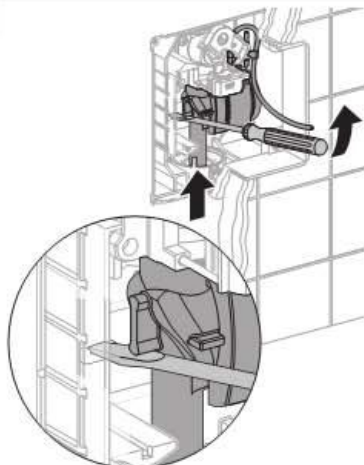

9

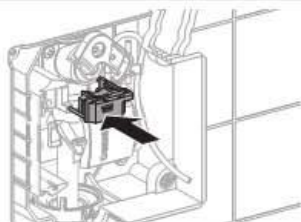

10

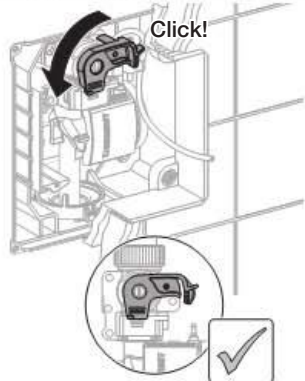

Szabályozó csavar cseréje

Előfeltételek

Nyomólap és nyomólap-rögzítő keret leszerelve.

Lásd "Szerviz, Nyomólap és nyomólap-rögzítő keret leszerelése".

1

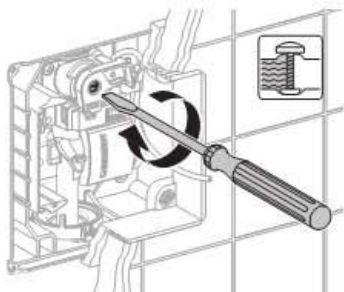

2 Zárja el a központi hidegvíz bekötést.

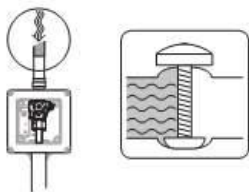

3

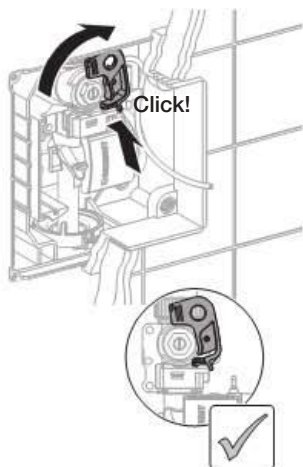

4



5

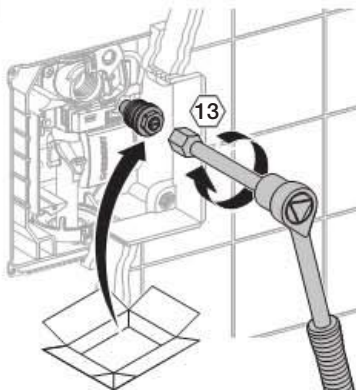

6

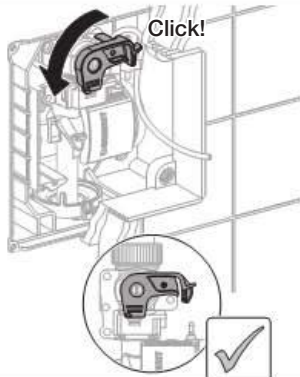

7

Nyissa ki a központi hidegvíz bekötést.



Öblítővezeték ajak tömítésének cseréje

Előfeltételek

Nyomólap és nyomólap-rögzítő keret leszerelve.

Lásd "Szerviz, Nyomólap és nyomólap-rögzítő keret leszerelése".

1

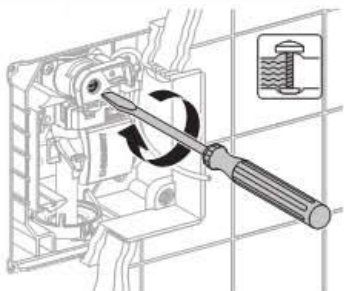

2

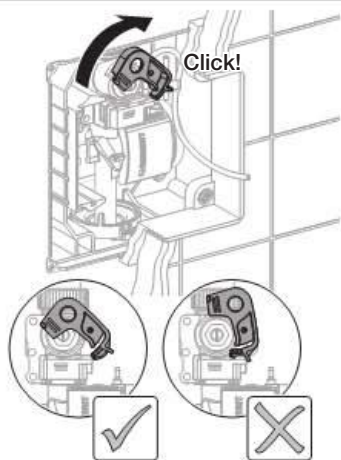

3

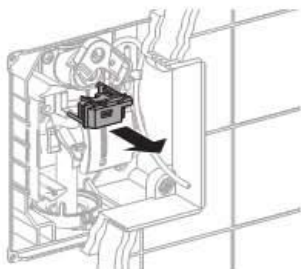

4

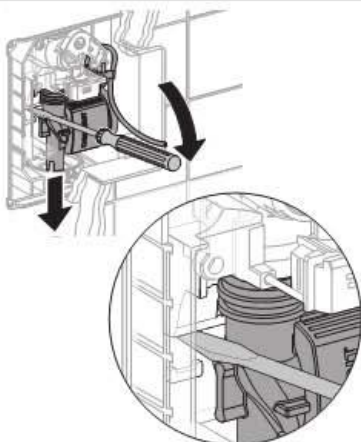

5

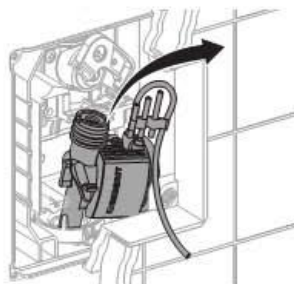

6

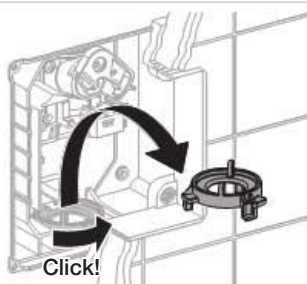

7

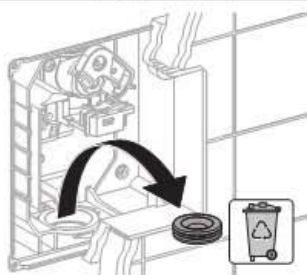

8



9

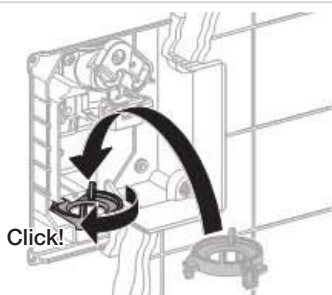

10

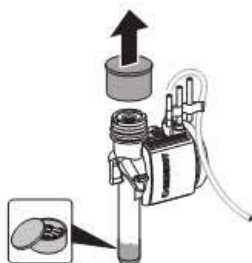

11

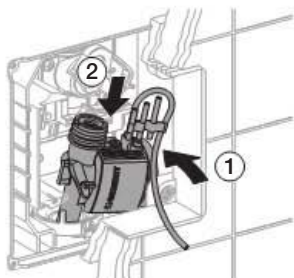

12

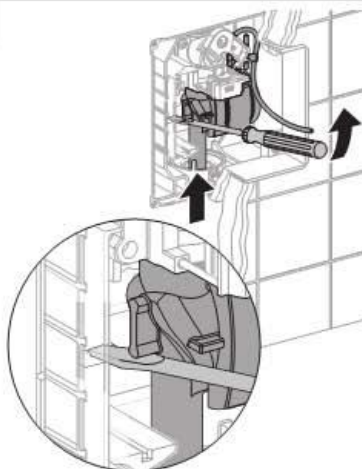

13

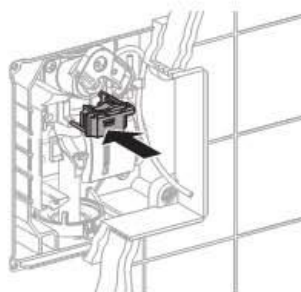

14

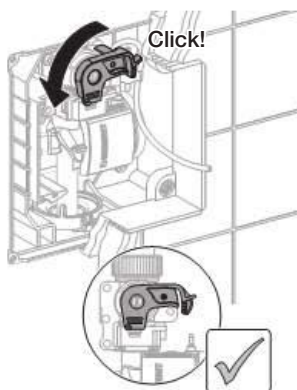

HU

Nyomólap-rögzítő keret és nyomólap felszerelése

1

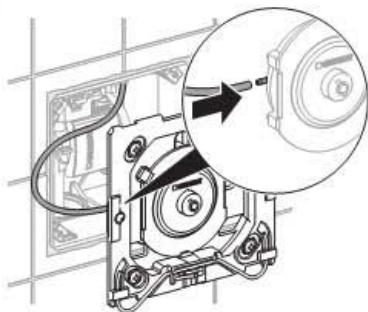

2

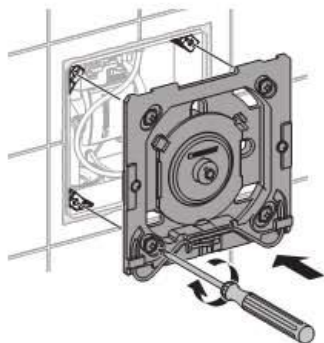

3

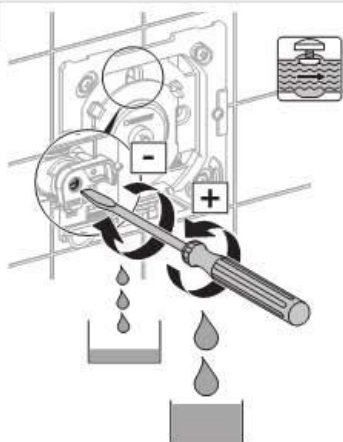

4

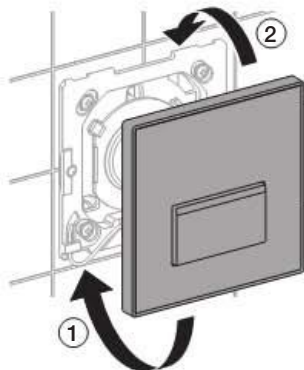

5

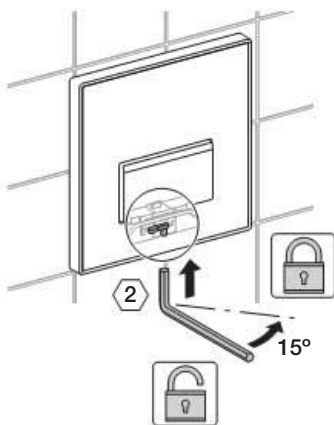

Műszaki adatok

HyTouch vizelde vezérlés pneumatika

Térfogatáram mennyisége 1 bar esetén	0,3 / 0,24 (térfogatáram korlátozóval)	l/s
Próbanyomás (víz)		16 bar
Próbanyomás (levegő/inertgáz)		3 bar
Működtető erő		< 12 N
Öblítési idő beállítási tartománya		4 / 8 / 12 s
Páratartalom		< 100 % (relatív)
Üzemi nyomástartomány		1 - 8 bar
Maximális üzemi vízhőmérséklet		30 °C

HU

Všeobecné pokyny

Tento návod na obsluhu

Návod na obsluhu uschovajte a v prípade potreby dajte k dispozícii odborníkovi.

Prevádzka, údržba

Užívateľ môže vykonávať údržbárske práce len v takom rozsahu, ako sú opísané v tomto návode.

Servis

Servisné práce môže vykonávať len odborník. Neodborné práce môžu viesť k nehodám, poškodeniam a poruchám v prevádzke.





Cieľová skupina

Tento dokument je určený pre odborníkov podľa EN IEC 62079:2001.

Použitie v súlade s určením

Riadenia pisoára HyTouch sú určené na splachovanie pisoárov. Pri použití na iné účely sú v prípade zranenia osôb a poškodenia majetku vylúčené nároky na ručenie a záruku.

Vysvetlivky

Symbol	Význam
	UPOZORNENIE Upozorňuje na možnú nebezpečnú situáciu, ktorá môže mať za následok ľahké alebo stredne ťažké zranenie alebo materiálne škody.
	Použite mazací tuk!
	Prívod vody z vodovodu je zatvorený
	Prívod vody z vodovodu je otvorený

SK

Kontakt

V prípade otázok alebo akýchkoľvek problémov kontaktuje prosím predajnú spoločnosť Geberit vo Vašej krajine alebo www.geberit.com.

Zloženie

Pneumatické riadenie pisoára HyTouch

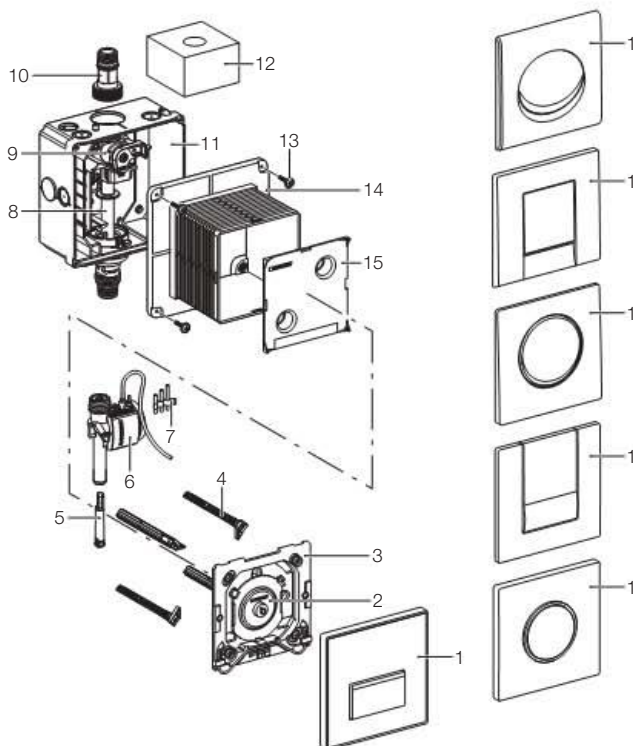

- 1 Obslužný panel
- 2 Pneumatické tlačidlo
- 3 Upevňovací rám
- 4 Dištančný čap
- 5 Regulátor prietoku
- 6 Pneumatický ventil
- 7 Súprava trysiek
- 8 Chránička
- 9 Uzatvárací ventil so škrtiacou klapkou
- 10 Prípojovacia vsuvka
- 11 Podomietková schránka
- 12 Ochranná špongia
- 13 Upevňovacie skrutky
- 14 Ochranná doska
- 15 Kryt ochrannej dosky

Údržba

Interval údržby

Nasledujúce údržbárske práce vykonávajúte podľa potreby, najneskôr však v uvedených intervaloch:

- Čistenie povrchu obslužného panelu - týždenne, vykoná prevádzkovateľ
- Čistenie košíkového filtra - každé 2 roky, vykoná odborník

Údržbárske práce

Čistenie obslužného panelu



UPOZORNENIE

Agresívne a abrazívne čistiace prostriedky by mohli povrch poškodiť.

- ▶ Nepoužívajte čistiace prostriedky s obsahom chlóru, kyselín, brusné alebo leptavé čistiace prostriedky, ale len jemné čistiace prostriedky a vodu.



Reklamácie škôd, ktoré sú spôsobené neodborným ošetrovaním čistiacimi prostriedkami, nemôžu byť uznané.

Čistenie alebo výmena košíkového filtra



SK

Servis

Hľadanie chyby

Problém	Možná príčina	Náprava
Voda netečie	Prívod vody je uzavretý	Otvorte prívod vody
	Košikový filter je upchaný alebo zašpinený	Vyčistite alebo vymeňte košíkový filter - Pozri "Údržba, Čistenie alebo výmena košíkového filtra"
	Žiadny tlak vo vodovodnej sieti	Prekontrolujte tlak vody - Obnovte tlak vody
	Konektor pneumatickej hadice medzi pneumatickým tlačidlom a pneumatickým ventilom je odpojený	Obnovte pripojenie konektora pneumatickej hadice
	Pneumatická hadica je zalomená alebo zlomená	Vymeňte poškodenú pneumatickú hadicu
Trvalý prietok (voda neprestáva tiecť)	Pneumatický ventil je poškodený	Vymeňte pneumatický ventil - Pozri "Servis, Výmena pneumatického ventilu"
	Škrtiaca klapka nie je dostatočne otvorená	Otvorte škrtiacu klapku
Pisoár je vyplachovaný nedostatočne		
Splachovacia voda strieka von z pisoára	Príliš vysoký prietok	Namontujte regulátor prietoku - Regulátor prietoku je dostupný ako príslušenstvo (242.484.00.1)

Servisné práce

Tento návod na opravu zobrazuje riadenie so zvislým vedením vody (A). Riadenie s vodorovným vedením vody (B) zobrazené nie je, ale servisné práce sú rovnaké.

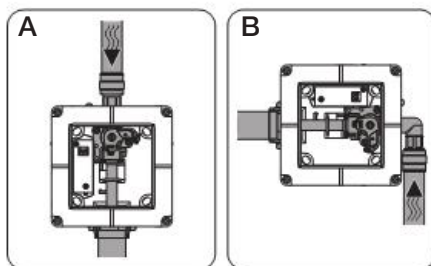

Tu sú opísané nasledovné servisné práce:

- Demontáž obslužného panelu a upevňovacieho rámu
- Výmena pneumatického ventilu
- Výmena škrtiacej skrutky
- Výmena prisávacieho tesnenia vedenia splachovania
- Montáž upevňovacieho rámu a obslužného panelu

Demontáž obslužného panelu a upevňovacieho rámu

1

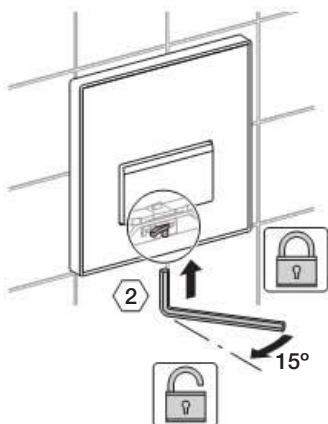

2

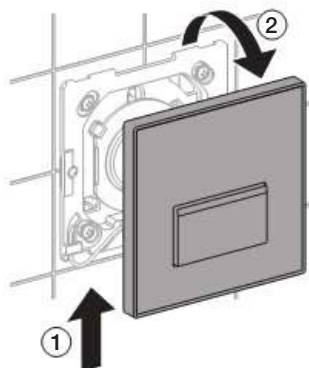

3

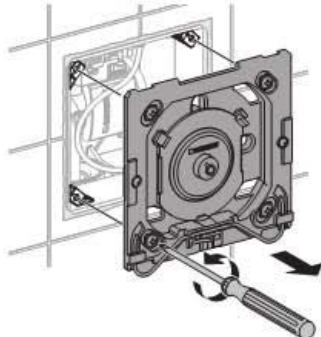

4

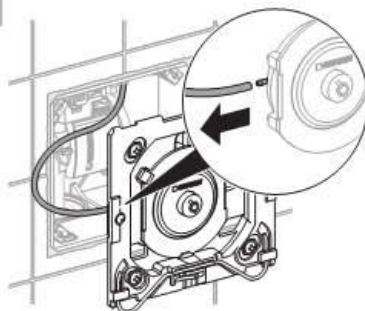

Výmena pneumatického ventilu

Predpoklady

Obslužný panel a upevňovací rám sú demontované.

Pozri "Servis, Demontáž obslužného panelu a upevňovacieho rámu".

1

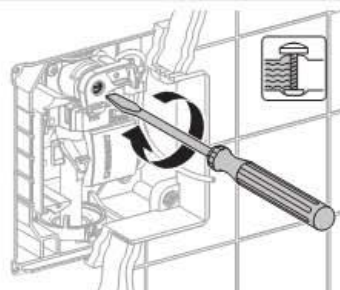

2

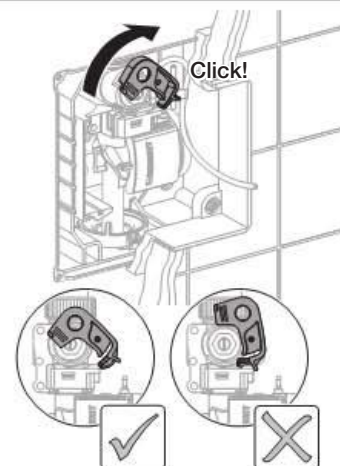

3

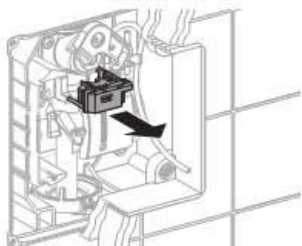

4

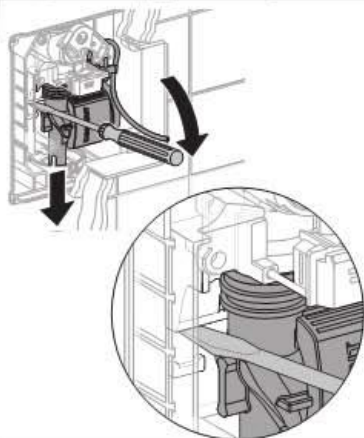

5

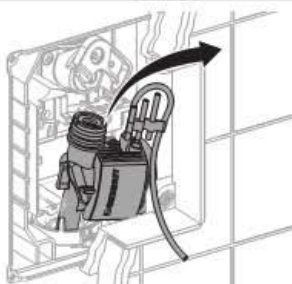

6

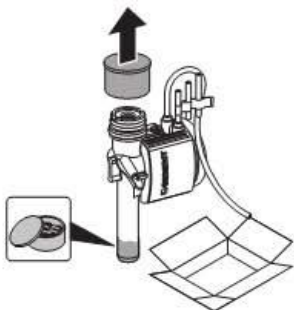

7

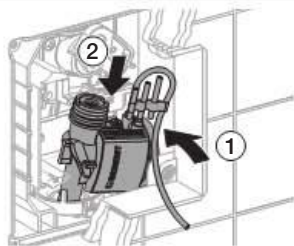

8

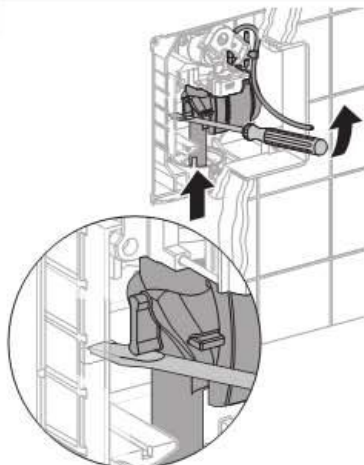

9

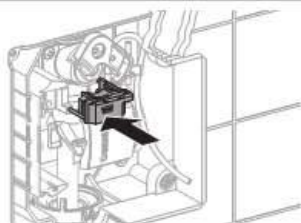

10

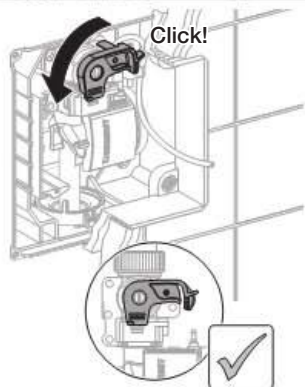

Výmena škrtiacej skrutky

Predpoklady

Obslužný panel a upevňovací rám sú demontované.

Pozri "Servis, Demontáž obslužného panelu a upevňovacieho rámu".

1

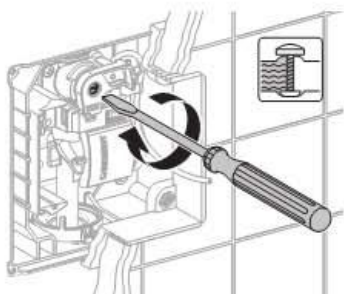

2 Zatvorte centrálny prívod vody.

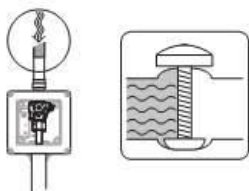

3

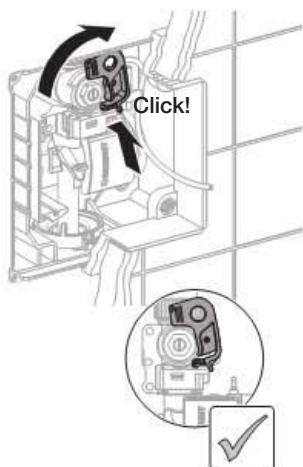

4



5

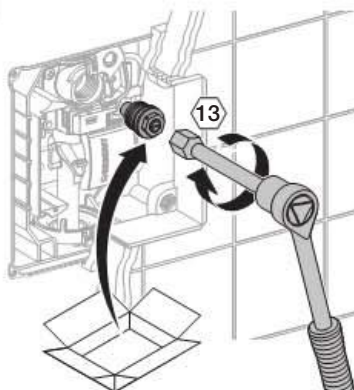

6

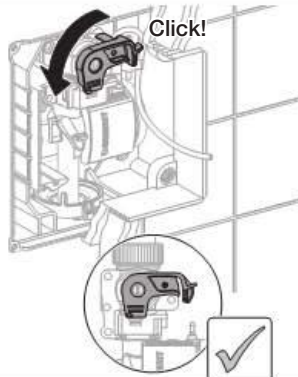

7 Otvorte centrálny prívod vody.



Výmena prisávacieho tesnenia vedenia splachovania

Predpoklady

Obslužný panel a upevňovací rám sú demontované.

Pozri "Servis, Demontáž obslužného panelu a upevňovacieho rámu".

1

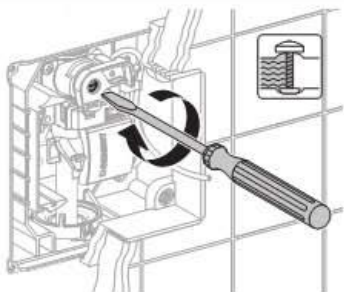

2

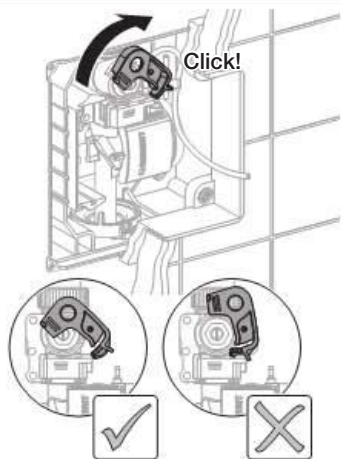

3

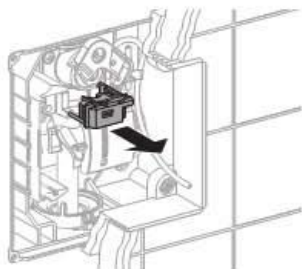

4

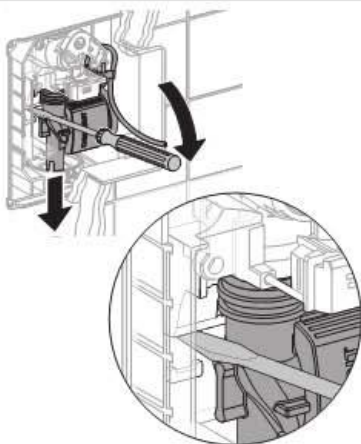

5

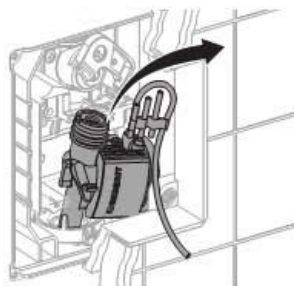

6

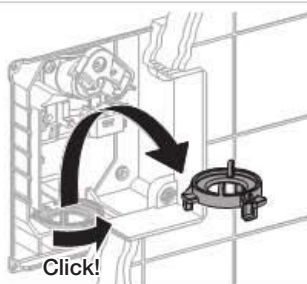

7

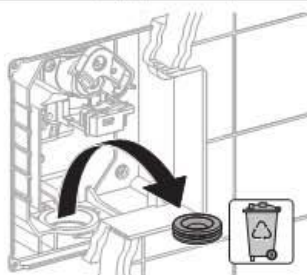

8



9

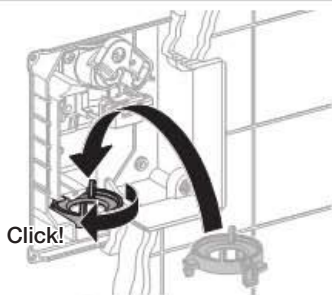

10

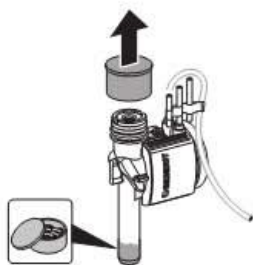

11

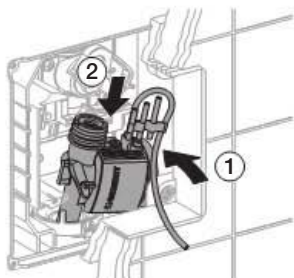

12

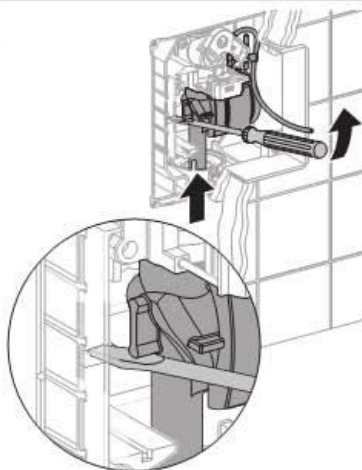

13

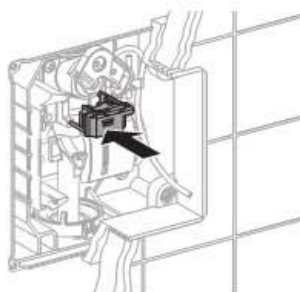

14

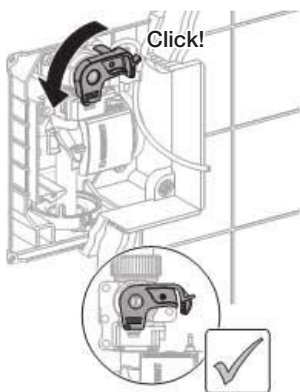

SK

Montáž upevňovacieho rámu a
obslužného panelu

1

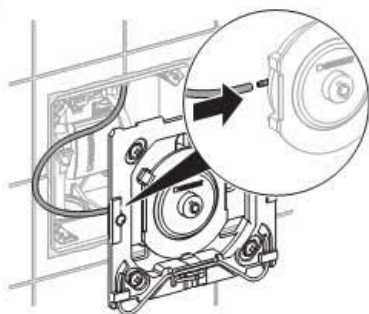

2

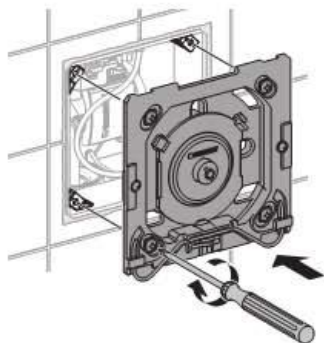

3

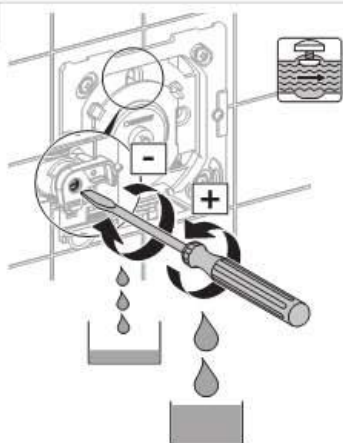

4

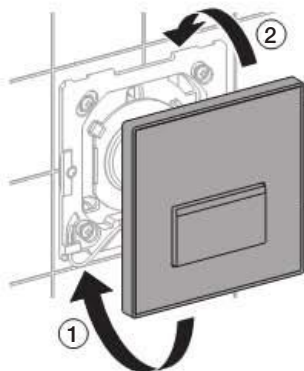

5

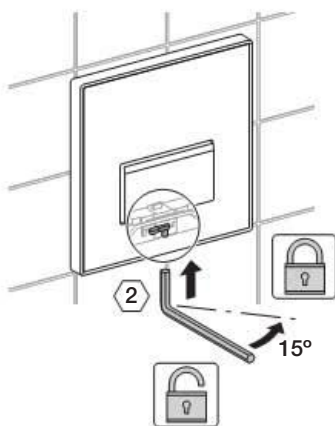

Technické údaje

Pneumatické riadenie pisoára HyTouch

Prietok pri 1 bar	0,3 / 0,24 (s regulátorom prietoku) l/s
Skúšobný tlak vody	0.16 MPa
Skúšobný tlak vzduchu/inertného plynu	0.3 MPa
Sila na spustenie	< 12 N
Rozsah nastavenia času splachovania	4 / 8 / 12 s
Vlhkosť vzduchu	< 100 % relatívna
Prevádzkový tlak	0,1 - 0,8 MPa
Prevádzková teplota vody max.	30 °C

SK

Všeobecná upozornění

- Tento návod k obsluze** Uschovejte návod k obsluze a v případě potřeby jej dejte odbornému pracovníkovi k dispozici.
- Provoz, údržba** Údržbářské práce smí uživatel provádět jen do té míry, jak je popsáno v tomto návodu.
- Servis** Servisní práce smí provádět jen odborný pracovník. Neodborné práce mohou vést k nehodám, hmotným škodám a provozním poruchám.





Cílová skupina

Tento dokument je určen odborným pracovníkům splňujícím požadavky normy EN IEC 62079:2001.

Použití v souladu s určením

HyTouch ovládání splachování pisoárů jsou určena ke splachování keramik pisoárů. Při použití k jinému účelu jsou nároky na záruku a nároky na ručení při škodách na zdraví a hmotných škodách vyloučeny.

Vysvětlivky k symbolům

Symbol	Význam
 POZOR	Upozorňuje na možnou nebezpečnou situaci, která může způsobit lehký nebo střední úraz nebo hmotné škody.
	Použijte mazací tuk!
	Pitná voda je odstavena.
	Pitná voda je přiváděna.

CZ

Kontakt

Máte-li otázky nebo problémy, kontaktujte příslušnou distribuční společnost Geberit nebo navštivte stránku www.geberit.com.

Konstrukce

Pneumatika HyTouch ovládání splachování pisoáru

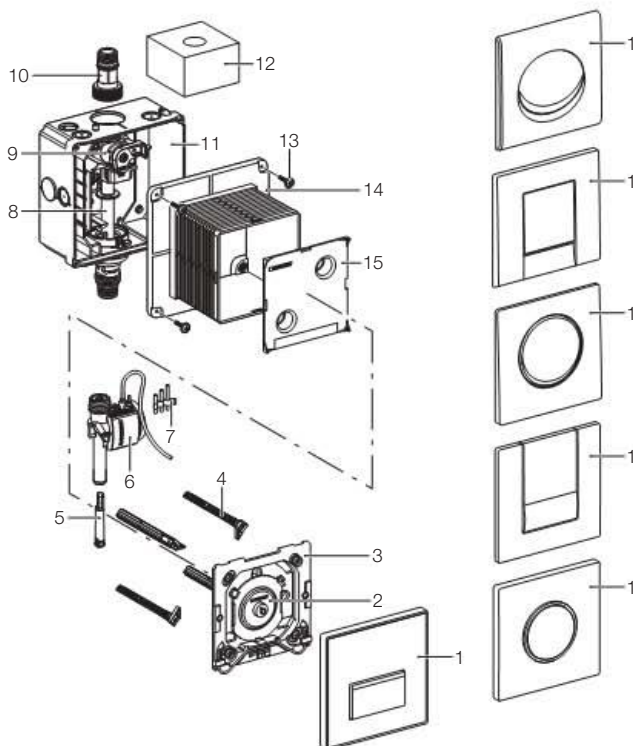

- 1 Ovládací tlačítko
- 2 Pneumatické tlačítko
- 3 Upevňovací rámeček
- 4 Stavitelná úchytka
- 5 Omezovač průtoku
- 6 Pneumatický ventil
- 7 Sada trysek
- 8 Trubková chránička
- 9 Uzavírací ventil s regulací
- 10 Připojovací vsuvka
- 11 Krabice pod omítku
- 12 Pěnová ochrana
- 13 Upevňovací šrouby
- 14 Kryt pro hrubou montáž
- 15 Ochranný kryt

Údržba

Interval údržby

Následující údržbářské práce provádějte podle potřeby, ale nejpозději v udaných intervalech:

- Čištění povrchu ovládacího tlačítka - jednou týdně, uživatelem
- Čištění košíkového filtru - každé 2 roky, odborníkem

Údržbářské práce

Čištění ovládacího tlačítka

POZOR
 Agresivní a abrazivní čisticí prostředky mohou povrch poškodit.

- ▶ Nepoužívejte čisticí prostředky s obsahem chloru, kyselin, brusné nebo žíravé čisticí prostředky, ale jenom jemné čisticí prostředky a vodu

i Reklamacie, které jsou způsobené neodborným ošetřováním čisticími prostředky, nemohou být uznány.

Vyčištění nebo výměna košíkového filtru



CZ

Servis

Hledání poruch

Problém	Možná příčina	Náprava
Voda neteče	Přívod vody je zavřený	Otevření přívodu vody
	Košíkový filtr je ucpaný nebo znečištěný	Vyčištění nebo výměna košíkového filtru - Viz "Údržba, čištění nebo výměna košíkového filtru"
	Žádný tlak v rozvodu vody	Kontrola tlaku vody - Obnovte tlak vody
	Zásuvný spoj vzduchové hadičky mezi pneumatickým tlačítkem a pneumatickým ventilem je přerušen	Zapojení zásuvného spoje vzduchové hadičky
	Vzduchová hadička je zlomená nebo prasklá	Výměna vadné vzduchové hadičky
Trvalý průtok (voda se nezastaví)	Pneumatický ventil je vadný	Výměna pneumatického ventilu - Viz "Servis, výměna pneumatického ventilu"
	Regulační ventil je málo otevřen	Otevření regulačního ventilu
Keramika pisoáru se vyplachuje nedostatečně	Regulační ventil je málo otevřen	Otevření regulačního ventilu
Splachovací voda stříká z keramiky pisoáru	Nadměrný průtok	Montáž omezovače průtoku - Omezovač průtoku lze zakoupit jako příslušenství (242.484.00.1)

Servisní práce

V tomto servisním návodu je znázorněno ovládání s vertikálním přívodem vody (A). Ovládání s horizontálním přívodem vody (B) není zobrazeno, servisní práce jsou ale stejné.

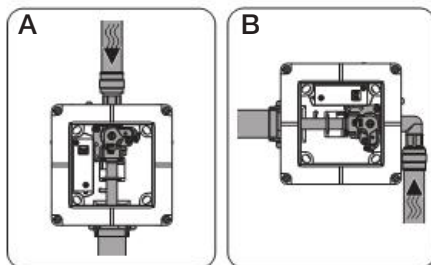

Jsou zde popsány následující servisní práce:

- Demontáž ovládacího tlačítka desky a upevňovacího rámečku
- Výměna pneumatického ventilu
- Výměna regulačního šroubu
- Výměna profilovaného těsnění splachovacího potrubí
- Montáž upevňovacího rámečku a ovládacího tlačítka

Demontáž ovládacího tlačítka a upevňovací rámečku

1

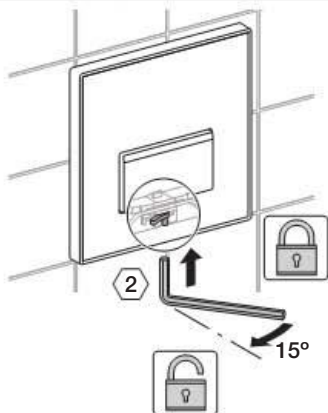

2

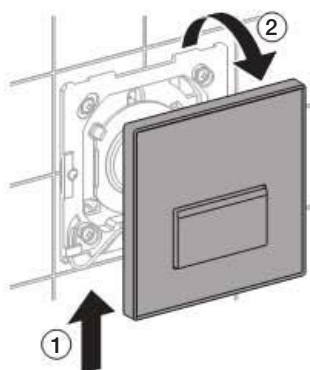

3

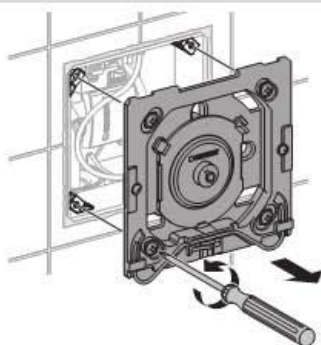

4

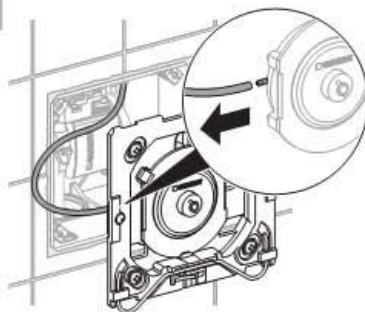

Výměna pneumatického ventilu

Předpoklady

Ovládací tlačítko a upevňovací rámeček jsou demontované.

Viz "Servis, demontáž ovládacího tlačítka a upevňovací rámečku".

1

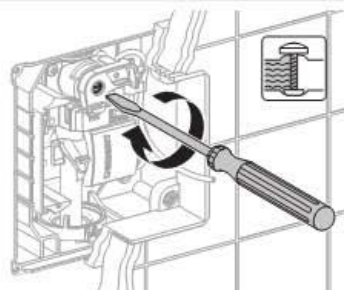

2

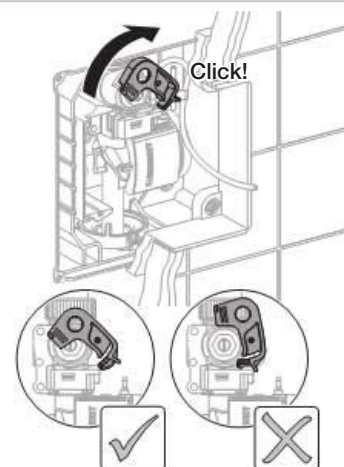

CZ

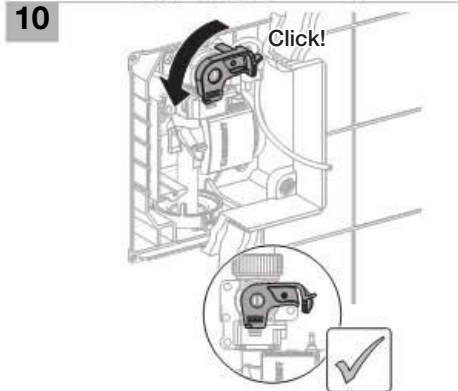
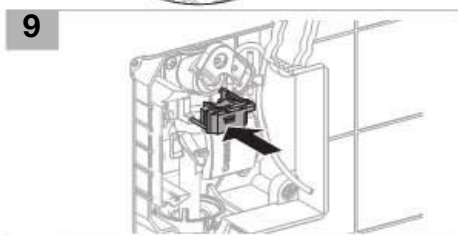
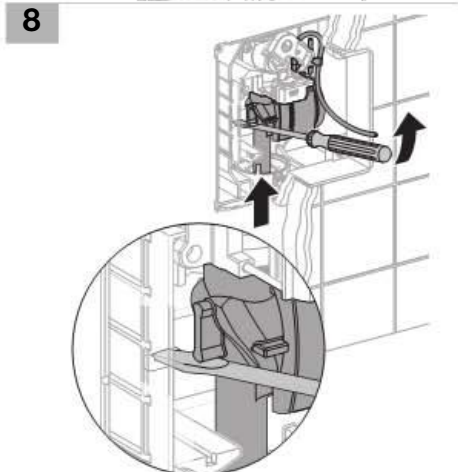
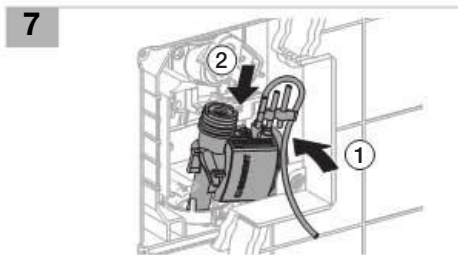
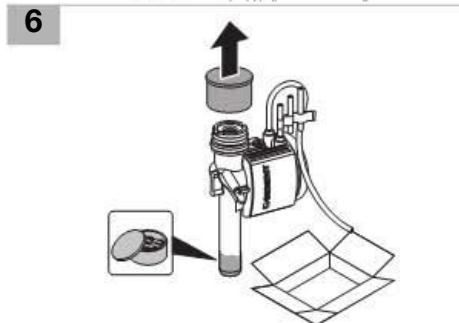
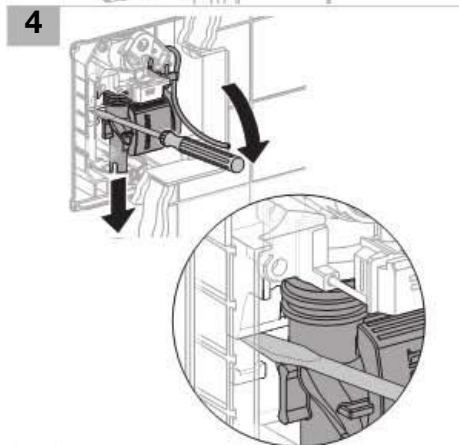
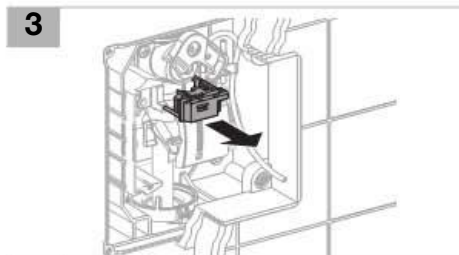

Výměna regulačního šroubu

Předpoklady

Ovládací tlačítko a upevňovací rámeček jsou demontované.

Viz "Servis, demontáž ovládacího tlačítka a upevňovacího rámečku".

1

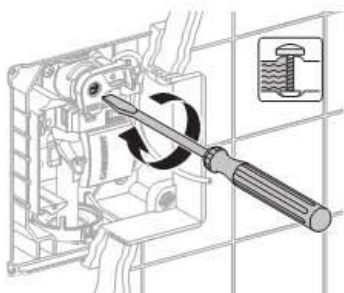

2 Zavřete centrální přívod vody.

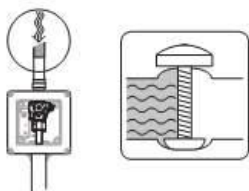

3

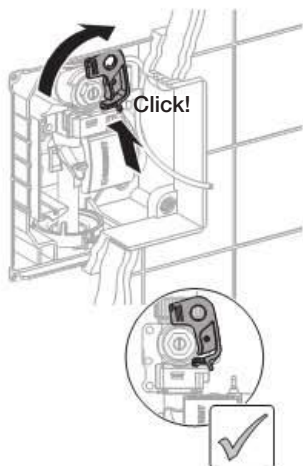

4

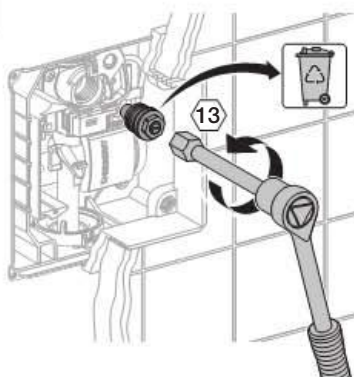

5

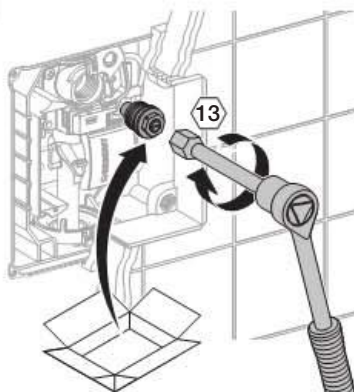

6

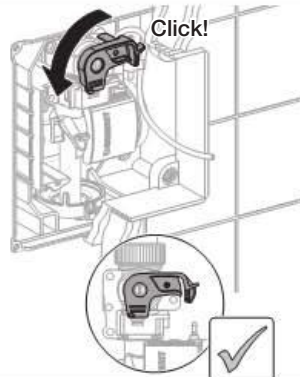

7 Otevřete centrální přívod vody.



CZ

Výměna profilovaného těsnění splachovacího potrubí

Předpoklady

Ovládací tlačítko a upevňovací rámeček jsou demontované.

Viz "Servis, demontáž ovládacího tlačítka a upevňovacího rámečku".

1

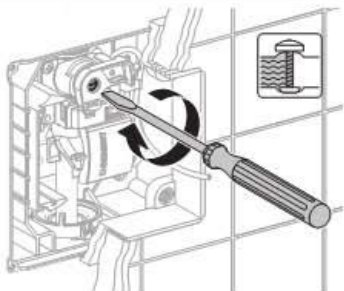

2

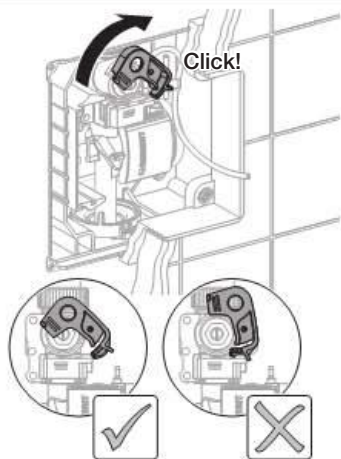

3

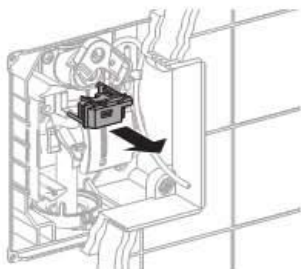

4

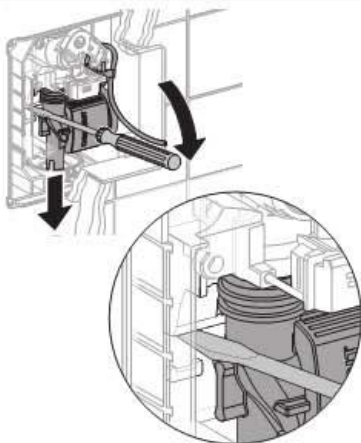

5

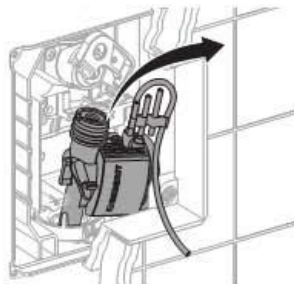

6

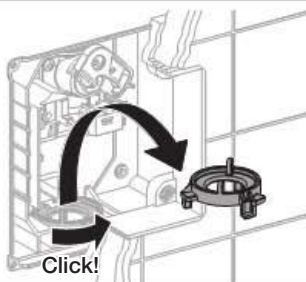

7

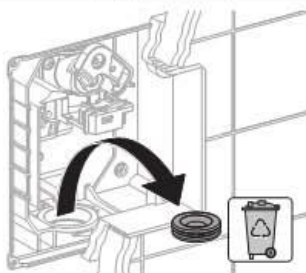

8



9



10

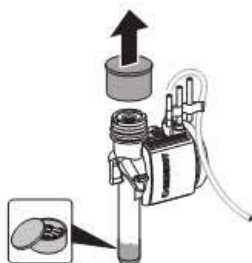

11

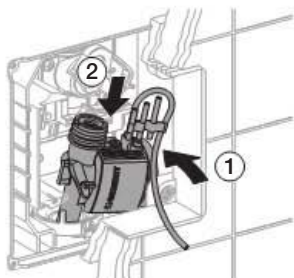

12

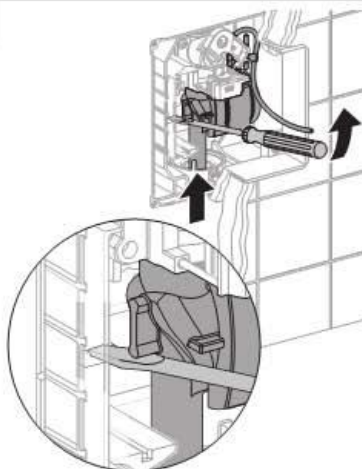

13

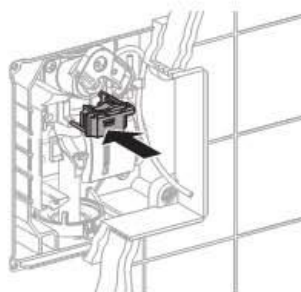

14

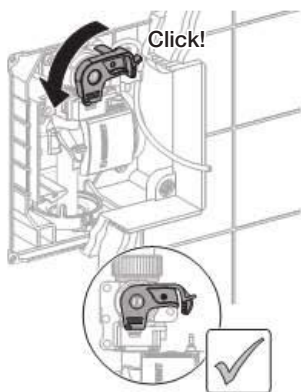

CZ

Montáž upevňovacieho rámečku a ovládacího tlačítka

1

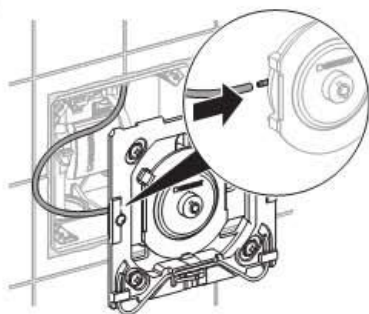

2

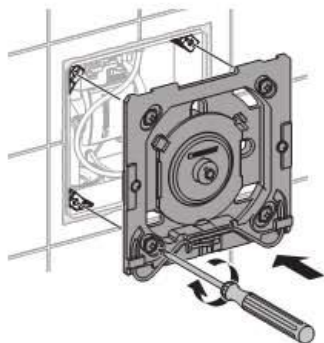

3

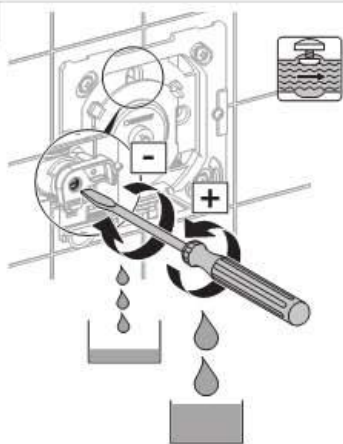

4

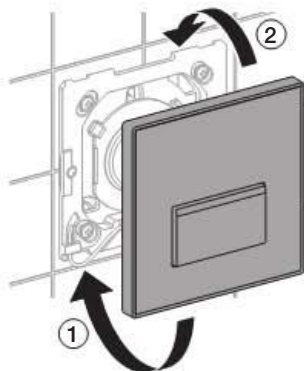

5

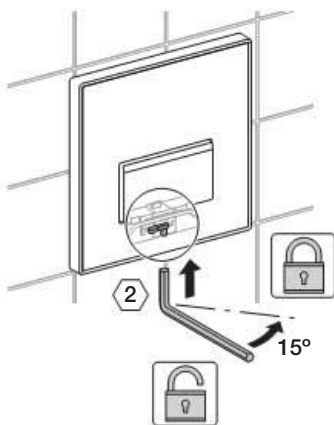

Technické informace

Pneumatika HyTouch ovládání splachování pisoáru

Průtok při 1 bar	0,3 / 0,24 (s omezovačem průtoku) l/s
Zkušební tlak vody	1.6 MPa
Zkušební tlak vzduchu / inertního plynu	0.3 MPa
Ovládací síla	< 12 N
Nast. rozsah splach. doby	4 / 8 / 12 s
Vlhkost vzduchu	< 100 % relat.
Provozní tlak	0.1 - 0.8 MPa
Provozní teplota vody max.	30 °C

CZ

Splošna navodila

Ta navodila za uporabo Navodila za uporabo skrbno shranite in jih po potrebi predložite strokovni osebi.

Upravljanje, vzdrževanje Vzdrževalna dela lahko opravlja upravljalec le do te mere, kot je navedeno v teh navodilih za uporabo.

Servis Servis lahko izvede le strokovna oseba. Pri nestrokovnem delu lahko pride do nesreč, materialne škode in napak v delovanju.





Ciljna skupina

Ta dokument je namenjen strokovnim osebam v skladu z EN IEC 62079:2001.

Namenska uporaba

HyTouch krmiljenja pisoarjev so namenjena za splakovanje keramika za pisoar. Pri spremembi namembnosti se garancijski zahtevki in poroštvene izjave pri poškodbah oseb in materialni škodi ne upoštevajo.

Pojasnilo simbolov

Simbol	Pomen
	POZOR Opozarja na možno nevarnost, ki lahko povzroči lažje ali srednje telesne poškodbe ali materialno škodo.
	Uporabite mast za mazanje!
	Pitna voda je zaprta
	Pitna voda je odprta

SL

Kontakt

Pri vprašanjih in problemih se lahko obrnete na prodajno podjetje Geberit v vaši državi ali na www.geberit.com.

Zgradba

Pnevmatika HyTouch krmiljenja pisoarjev

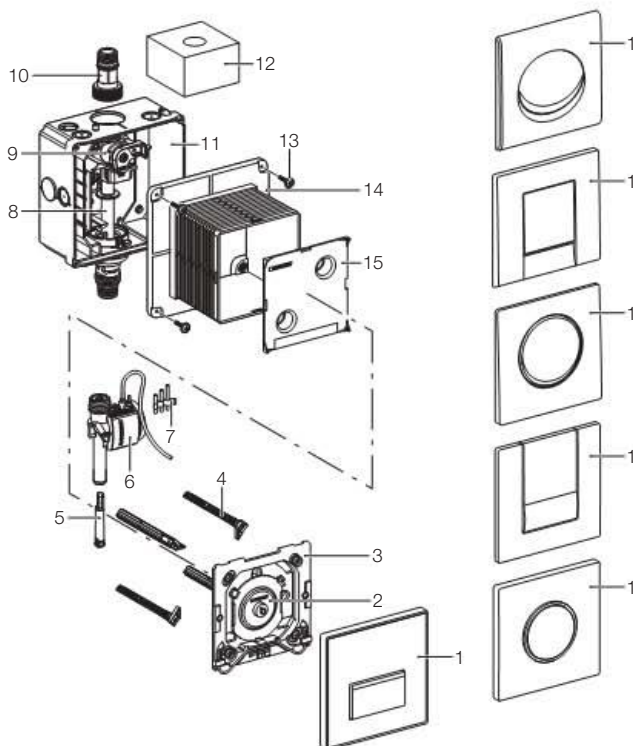

- 1 Ak ivirna tipka
- 2 Pnevmatiski aktivirni gumb
- 3 Pritrdilni okvir
- 4 Distančni sorniki
- 5 Omejitnik pretočne količine
- 6 Pnevmatiski ventil
- 7 Vložek šobe
- 8 Prazna cev
- 9 Zaporni ventil z dušilko
- 10 Priključni nastavek
- 11 PO ohišje
- 12 Zaščitna pena
- 13 Pritrditveni vijaki
- 14 Vgradna garnitura
- 15 Zaščitni pokrov

Vzdrževanje

Interval vzdrževanja

Naslednja vzdrževalna dela je treba izvesti po potrebi, vendar najkasneje v navedenih intervalih:

- čiščenje površine aktivirne tipke – enkrat tedensko, opravi upravljavec,
- čiščenje filtrskega koša – na 2 leti, opravi strokovna oseba.

Vzdrževalno delo

Čiščenje tipke



POZOR

Agresivna in groba čistilna sredstva lahko poškodujejo površino.

- ▶ Ne uporabljajte čistil z vsebnostjo klora, kislin, ostrih delcev in jedkih snovi, ampak le blaga čistila in vodo



Reklamacij zaradi nepravilne uporabe čistilnih sredstev, ne moremo upoštevati.

Očistite ali zamenjajte filtrski koš



Servis

Iskanje napak

Težava	Možen vzrok	Pomoč
Voda ne teče	Dovod vode je zaprt	Odpri dovod vode
	Filtrski koš je zamašen ali zamazan	Očistite ali zamenjajte filtrski koš • Glejte »Vzdrževanje, čiščenje ali zamenjava filtrskega koša«
	V omrežju ni tlaka	Preverite vodni tlak • Ponovno vzpostavite vodni tlak
	Natični spoj pnevmatske cevi med pnevmatsko tipko in pnevmatskim ventilom je ločen	Ponovno povežite natični spoj pnevmatske cevi
	Pnevmatska cev je prepognjena ali zlomljena	Zamenjajte pnevmatsko cev, ki je v okvari
Trajno izlivanje (voda se ne ustavi)	Pnevmatski ventil je v okvari	Zamenjajte pnevmatski ventil • Glejte »Servis, menjava pnevmatskega ventila«
	Pnevmatski ventil je v okvari	Zamenjajte pnevmatski ventil • Glejte »Servis, menjava pnevmatskega ventila«
Keramika za pisoar se ne izpira dovolj	Dušilka ni dovolj odprta	Odpri dušilko
Splakovalna voda brizga iz keramike za pisoar	Prevelika pretočna količina	Montirajte omejitnik pretočne količine • Omejitnik pretočne količine je na voljo kot pribor (242.484.00.1)

Servis

Ta navodila za servisiranje prikazujejo krmiljenje z navpičnim cevovodom (A). Krmiljenje z vodoravnim cevovodom (B) ni prikazano, servis pa je enak.

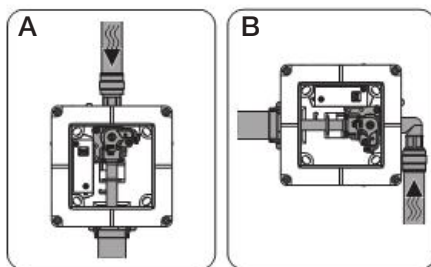

Tukaj so opisani naslednji servisi:

- Demontiranje aktivirne tipke in pritrdilnega okvirja
- Menjava pnevmatskega ven ila
- Menjava dušilnega vijaka
- Menjava tesnila cevovoda za splakovanje
- Montiranje pritrdilnega okvirja in aktivirne tipke

Demontiranje aktivirne tipke in pritrdilnega okvirja

1

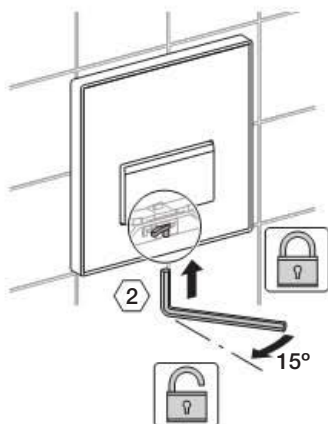

2

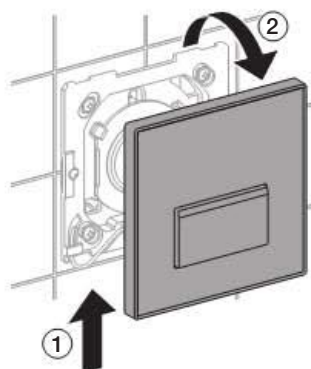

3

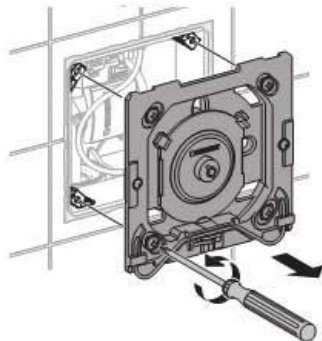

4

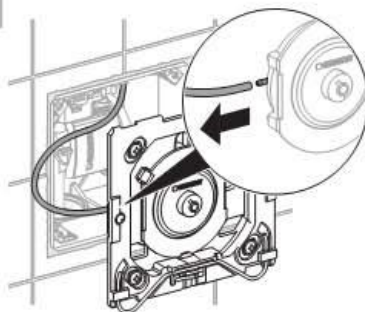

Menjava pnevmatskega ventila

Predpostavke

Aktivirna tipka in pritrdilni okvir sta demontirana. Glejte »Servis, demontiranje aktivirne tipke in pritrdilnega okvirja«.

1

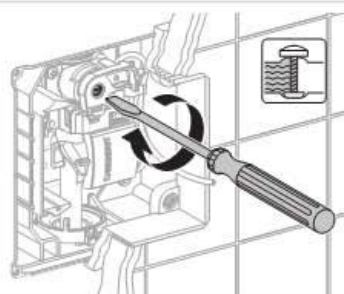

2

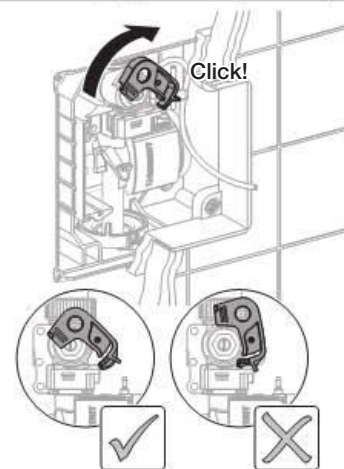

3

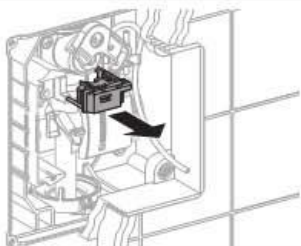

4

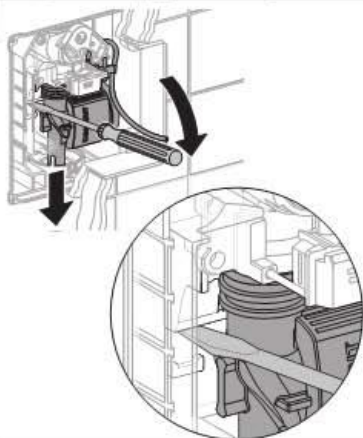

5

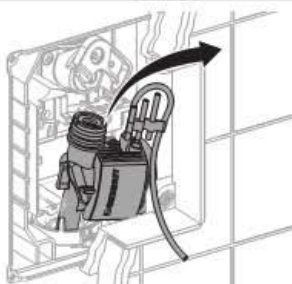

6

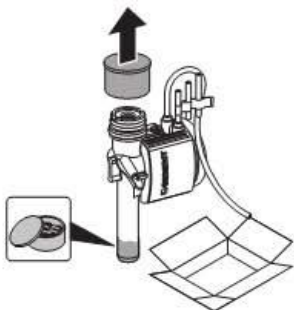

7

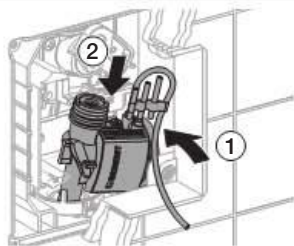

8

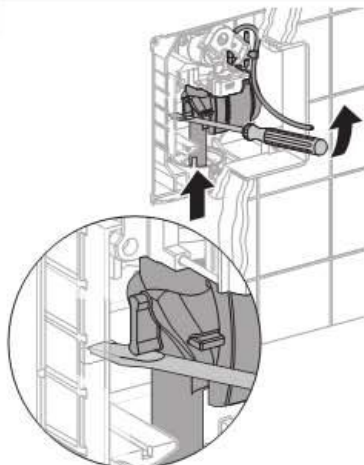

9

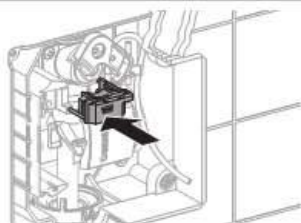

10

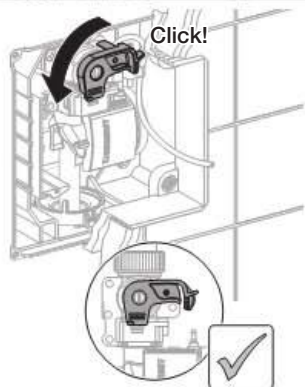

Menjava dušilnega vijaka

Predpostavke

Aktivirna ipka in pritrdilni okvir sta demontirana.
Glejte »Servis, demontiranje aktivirne tipke in pritrdilnega okvirja«.

1

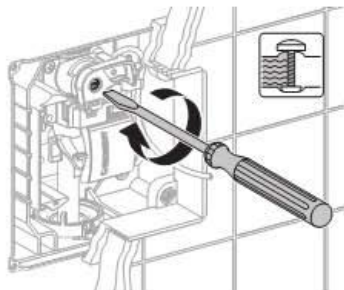

2 Zaprite centralni dovod vode.

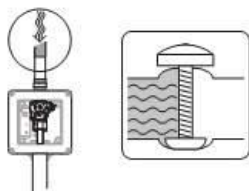

3

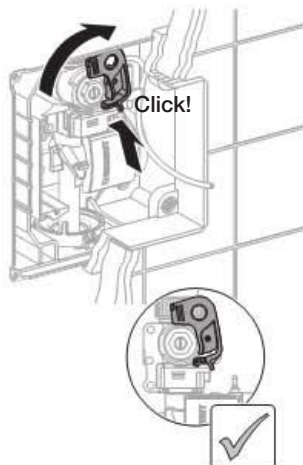

4

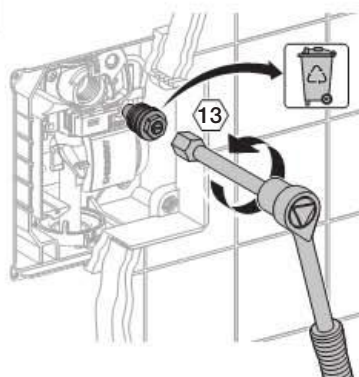

5

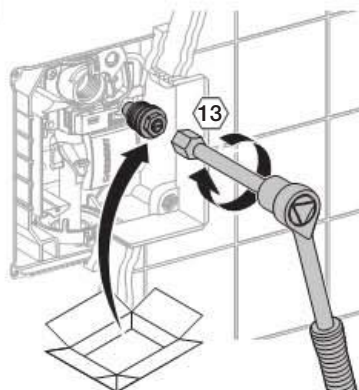

6

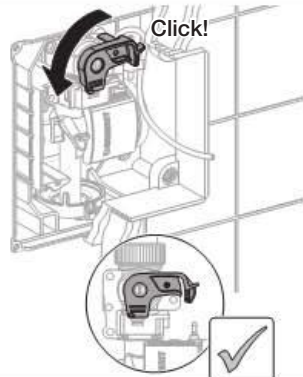

7 Odprite centralni dovod vode.



Menjava tesnila cevovoda za splakovanje

Predpostavke

Aktivna tipka in pritrdilni okvir sta demontirana. Glejte »Servis, demontiranje aktivne tipke in pritrdilnega okvirja«.

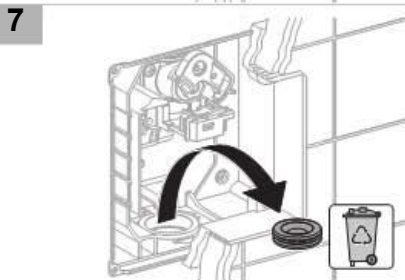
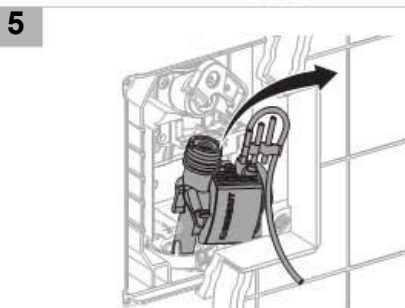
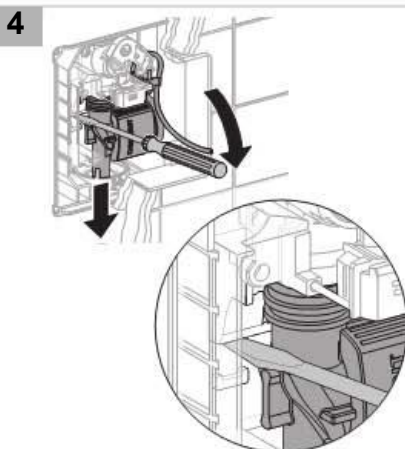
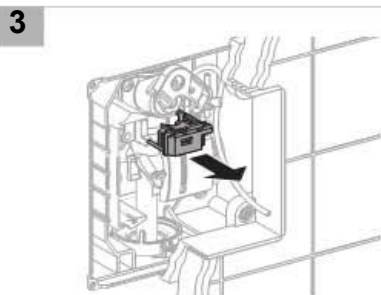
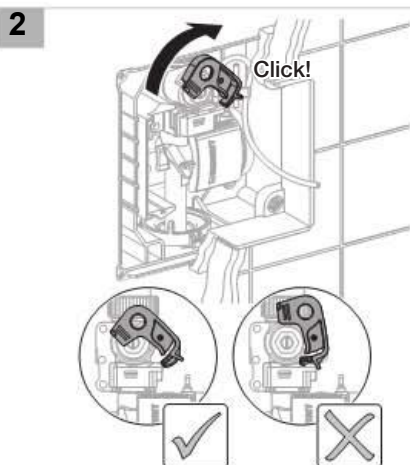
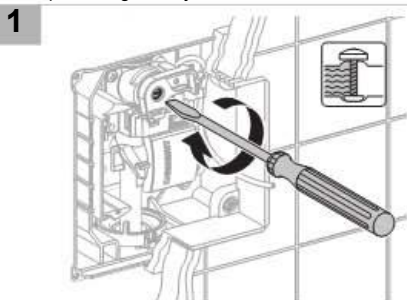

8



9

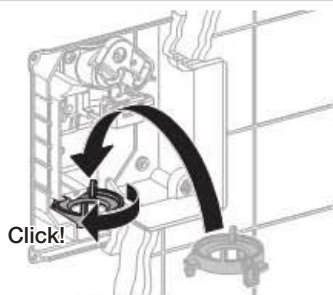

10

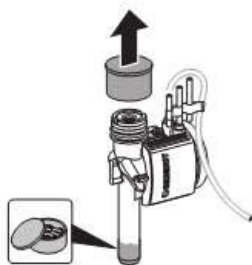

11

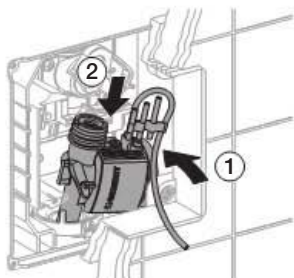

12

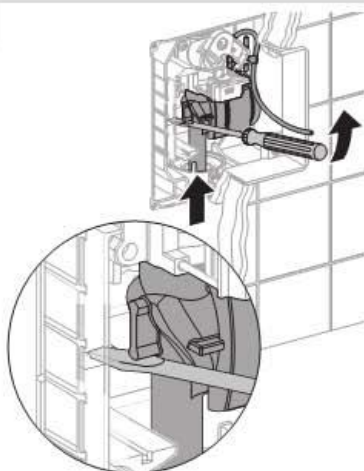

13

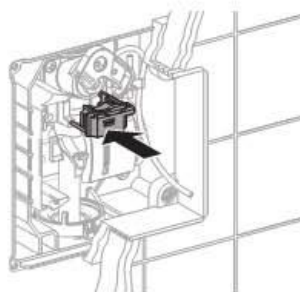

14

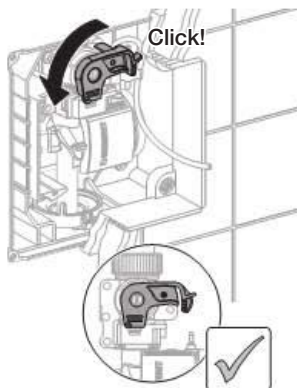

SL

Montiranje pritrdilnega okvirja in aktivirne tipke

1

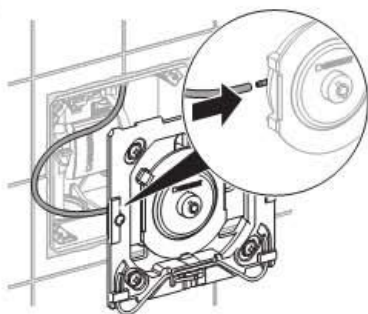

2

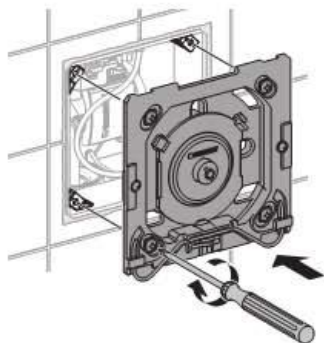

3

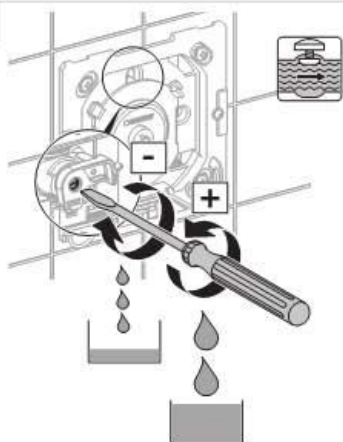

4

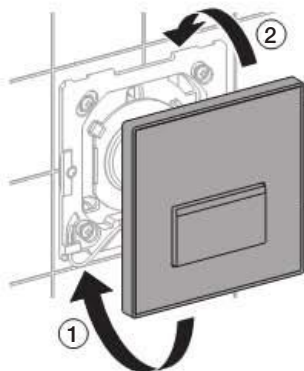

5

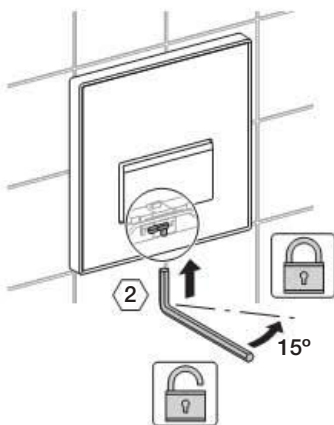

Tehnični podatki

Pnevmatika HyTouch krmiljenja pisoarjev

Pretočna količina pri 1 baru	0,3 / 0,24 (z omejitnikom pretočne količine) l/s
Testni tlak vode	16 bar
Testni tlak zraka/inertnega plina	3 bar
Sprožilna moč	< 12 N
Nastavitev časa splakovanja	4 / 8 / 12 s
Vlažnost zraka	< 100 % relativ
Območje tlaka med delovanjem	1 - 8 bar
Najvišja temperatura vode	30 °C

SL

Osnovne informacije

Ove pogonske upute	Čuvajte pogonske upute i po potrebi stavite na raspolaganje tehničkom stručnjaku.
Prodaja, održavanje	Trgovci smiju provoditi samo one radove na održavanju koje dozvoljavaju ove upute.
Servis	Servis smije provoditi samo tehnički stručnjak. Nestručni radovi mogu dovesti do nezgoda, oštećenja i smetnji u radu.





Ciljana grupa

Ovaj je dokument namijenjen tehničkim stručnjacima sukladno EN IEC 62079:2001.

Namjena

HyTouch uređaji za aktiviranje ispiranja pisoara namijenjeni su ispiranju keramike pisoara. U slučaju da prilikom korištenja sustava u druge svrhe dođe do tjelesnih ozljeda ili materijalne štete, garancija i potvrda o odgovornosti ne pokrivaju troškove.

Objašnjenje simbola

Simbol	Značenje
	OPREZ Upućuje na moguću opasnu situaciju koja može prouzrokovati lakše ili srednje tjelesne ozljede ili materijalnu štetu.
	Koristiti mazivno sredstvo!
	Pitka voda je isključena
	Pitka voda je uključena

HR

Kontakt

Za pitanja ili probleme kontaktirajte ovlaštenu prodavaonicu Geberitovih proizvoda ili preko internetske lokacije www.geberit.com.

Građa

Pneumatika HyTouch uređaja za aktiviranje ispiranja pisoara

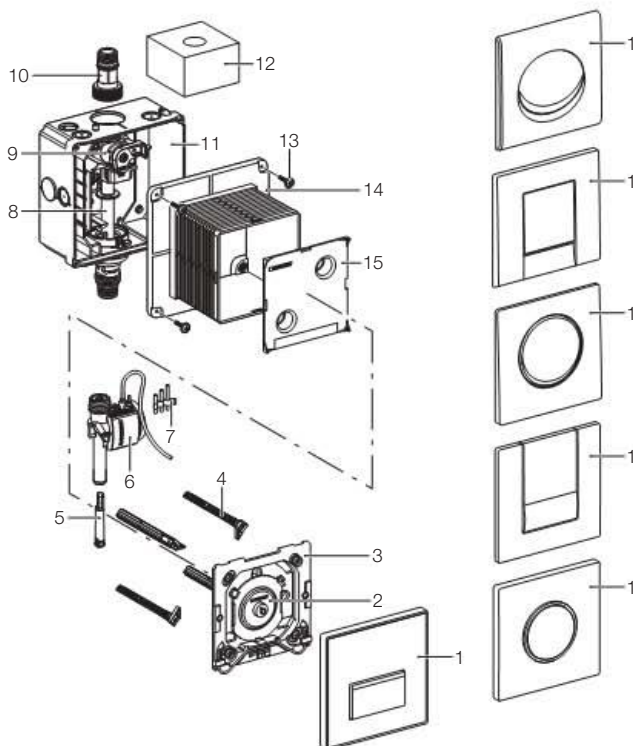

- 1 Tipka za aktiviranje
- 2 Pneumatski prekidač
- 3 Montažni okvir
- 4 Vijci za razmak
- 5 Graničnik protoka
- 6 Pneumatski ventil
- 7 Set cjevčica
- 8 Prazna cijev
- 9 Zaporni ventil s navojem za podešavanje
- 10 Priklučni nipl
- 11 Ugradbeni set
- 12 Zaštitna spužva
- 13 Vijci za pričvršćenje
- 14 Zaštitna kuća
- 15 Poklopac zaštitne kutije

Održavanje

Period održavanja

Sljedeći se radovi na održavanju provode po potrebi, no najkasnije u navedenim vremenskim razmacima:

- Čišćenje tipke za aktiviranje - tjedno, rukovaoc
- Čišćenje košarice filtra - svake 2 godine, tehnički stručnjak

Rad na održavanju

Čišćenje tipke



OPREZ

Vrlo jaka sredstva i sredstva za ribanje mogu oštetiti površinu.

- ▶ Nemojte koristiti sredstva koja sadrže klor, kiseline, brusna ili nagrizajuća sredstva, nego samo blaga sredstva za čišćenje i vodu



Reklamacije koje su posljedica štete nastale nestručnom upotrebom sredstva za čišćenje neće se uvažiti.

Čišćenje ili promjena košarice filtra



Servis

Otklanjanje kvarova

Problem	Mogući uzrok	Uklanjanje smetnje
Voda ne teče	Zatvoren je ventil za vodu	Otvoriti ventil za vodu
	Košarica filtra je začepljena ili zamazana	Očistiti ili promijeniti košaricu filtra • Vidi "Održavanje, Čišćenje ili promjena košarice filtra"
	Nema pritiska na razvod vode	Provjeriti pritisak vode • Ponovno uspostavite pritisak vode
	Strujni priključak pneumatskog crijeva između pneumatskog prekidača i pneumatskog ventila je odvojen	Uspostaviti strujni priključak pneumatskog crijeva
	Pneumatsko crijevo je nagnečeno ili slomljeno	Zamijeniti neispravno pneumatsko crijevo
Kontinuirano tečenje (voda ne prestaje teći)	Pneumatski ventil nije ispravan	Zamijeniti pneumatski ventil • Vidi "Servis, promjena pneumatskog ventila"
	Navoj za podešavanje nije dovoljno otvoren	Otvoriti navoj za podešavanje
Nedovoljno ispiranje keramike pisoara	Prevelik protok	Montirati graničnik protoka • Graničnik protoka može se dobiti kao pribor (242.484.00.1)

Popravci

Upute za popravak pokazuju upravljanje s vertikalnim vođenjem vode (A). Upravljanje s horizontalnim vođenjem vode (B) nije prikazano, no popravci su identični.

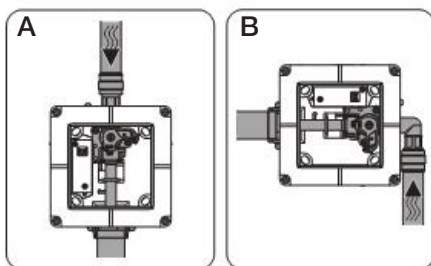

Ovdje su opisani sljedeći popravci:

- Demontiranje tipke za aktiviranje i pričvrsnog okvira
- Zamjena pneumatskog ventila
- Zamjena prigušnog vijka
- Zamjena brtve voda za ispiranje
- Montiranje pričvrsnog okvira i tipke za aktiviranje

Demontiranje tipke i pričravnog okvira

1

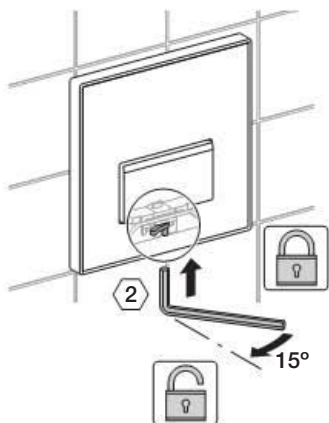

2

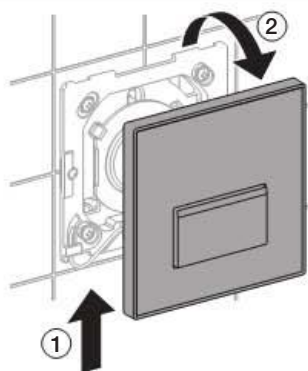

3

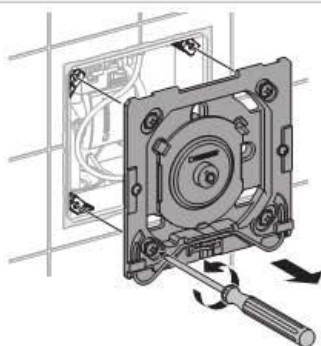

4

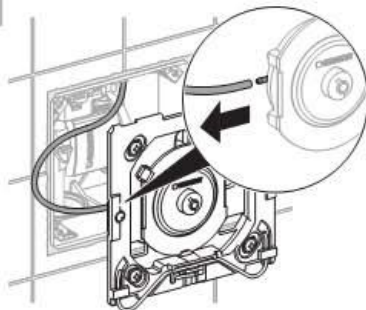

Zamjena pneumatskog ventila

Pretpostavke

Tipka za aktiviranje i pričrveni okvir su demontirani.

Vidi "Servis, demontaža tipke za aktiviranje i pričravnog okvira".

1

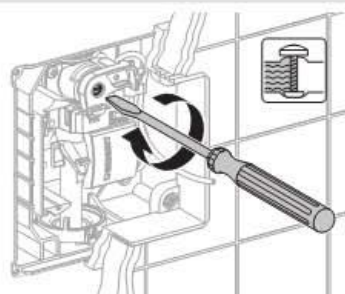

2

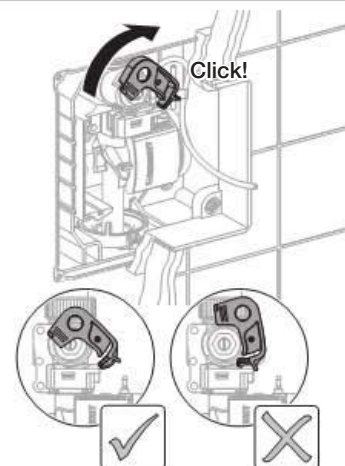

HR

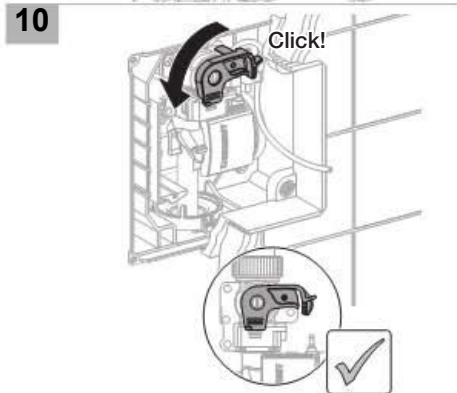
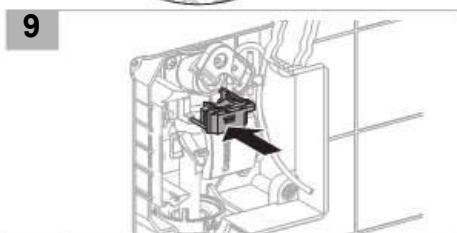
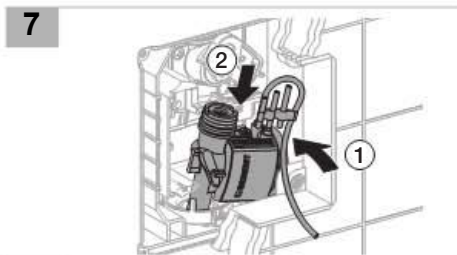
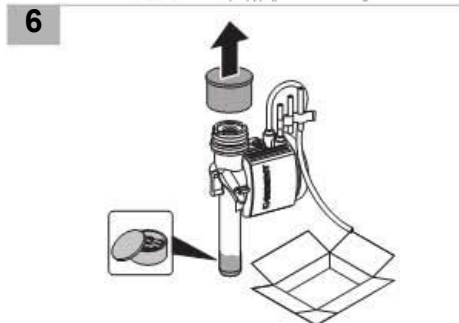
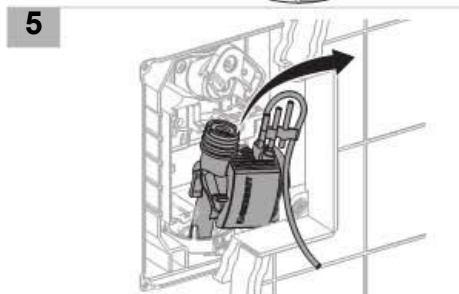
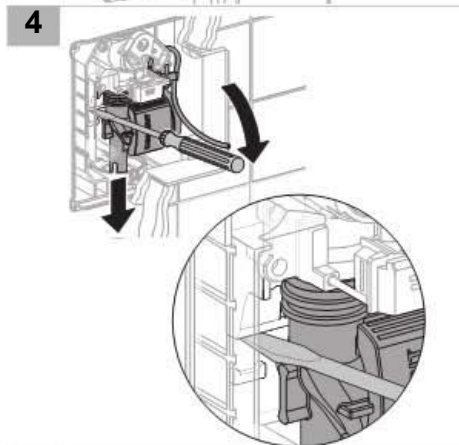
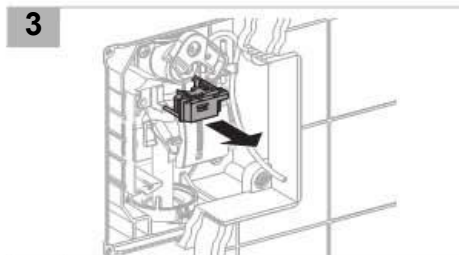

Zamjena prigušnog vijka

Pretpostavke

Tipka za aktiviranje i pričvrtni okvir su demontirani.

Vidi "Servis, demontaža tipke za aktiviranje i pričvrstnog okvira".

1

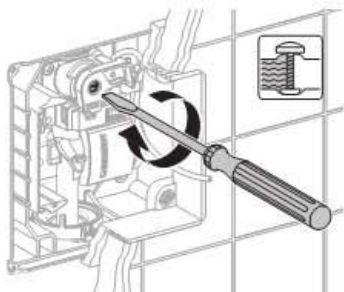

2 Zatvorite glavni ventil za vodu.

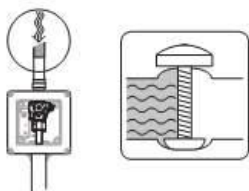

3

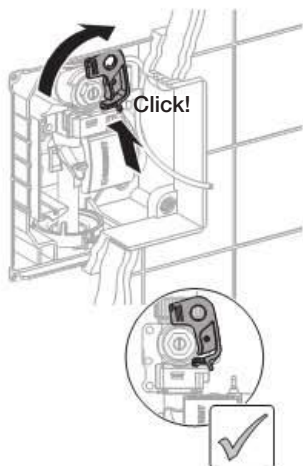

4



5

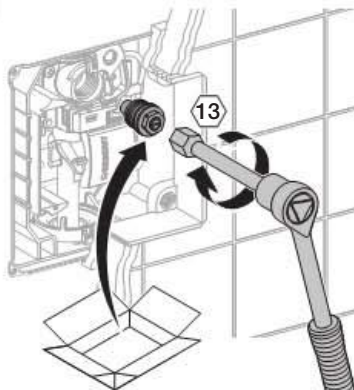

6

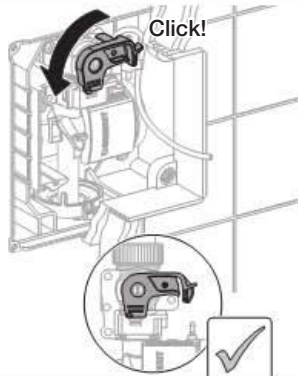

7 Otvorite glavni ventil za vodu.



Zamjena brtve voda za ispiranje

Pretpostavke

Tipka za aktiviranje i pričvrtni okvir su demontirani.

Vidi "Servis, demontaža tipke za aktiviranje i pričvrtnog okvira".

1

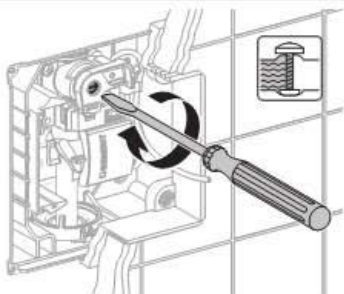

2

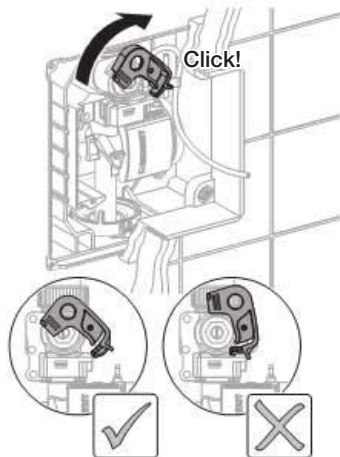

3

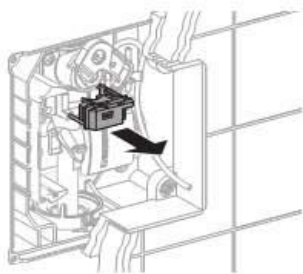

4

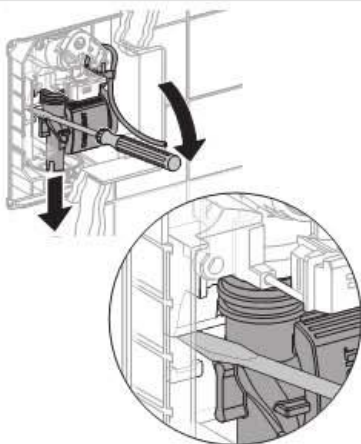

5

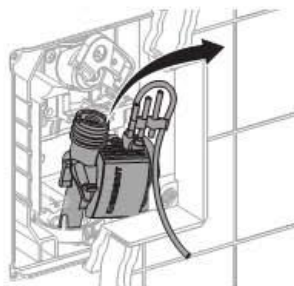

6

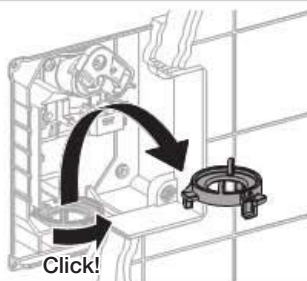

7

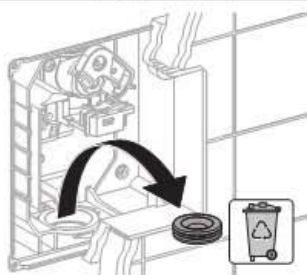

8



9



10

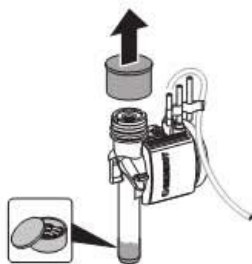

11

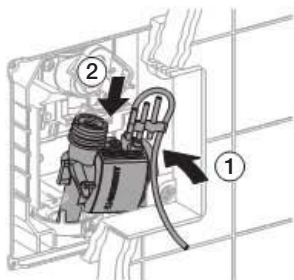

12

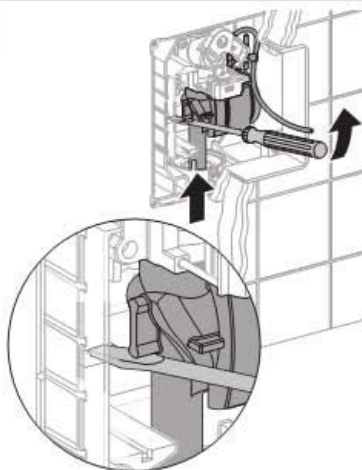

13

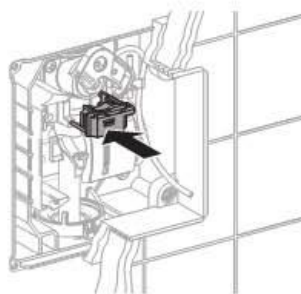

14

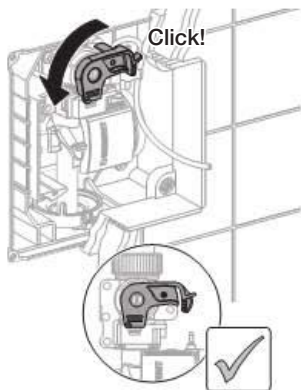

HR

Montiranje pričvrstnog okvira i tipke za aktiviranje

1

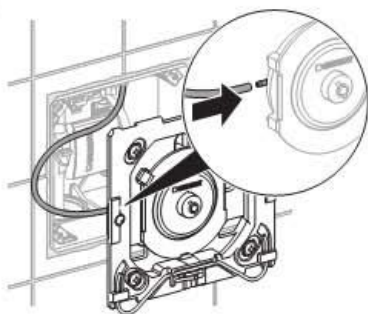

2

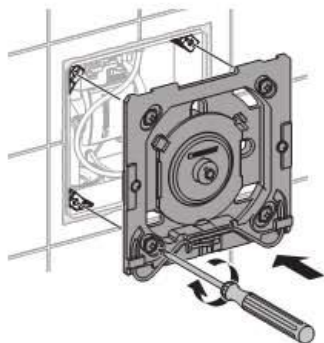

3

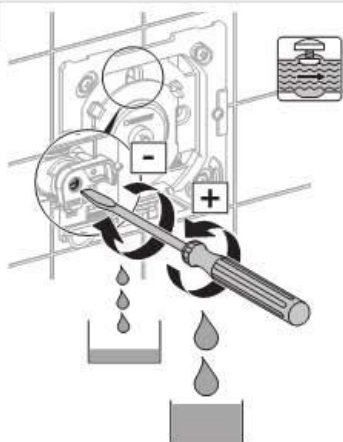

4

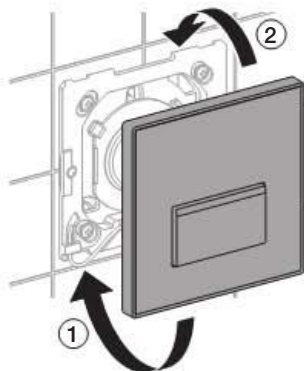

5

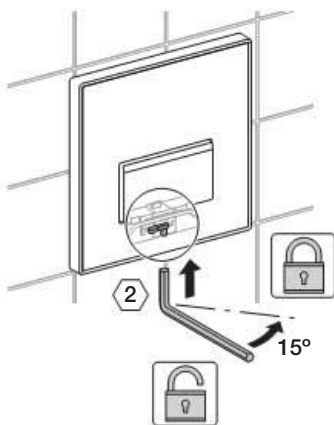

Tehnički podaci

Pneumatika HyTouch uređaja za aktiviranje ispiranja pisoara

Količina protoka kod 1 bara	0,3 / 0,24 (s graničnikom protoka) l/s
Ispitni tlak vode	16 bar
Ispitni tlak zraka/ inertnog plina	3 bar
Sila aktiviranja	< 12 N
Područje podešavanja vremena ispiranja	4 / 8 / 12 s
Vlažnost zraka	< 100 % relativ
Raspon radnog tlaka	1 - 8 bar
Maks. radna temperatura vode	30 °C

Opšte informacije

- Ovaj priručnik za upotrebu** Sačuvajte priručnik za upotrebu i po potrebi ga stavite na raspolaganje tehničkom stručnjaku.
- Rukovanje, održavanje** Operator sme da vrši samo one radove na održavanju koji su opisani u ovom uputstvu.
- Servisiranje** Servis sme da obavi samo tehnički stručnjak. Nestručni zahvati na uređaju mogu da dovedu do nesreća, oštećenja materijala i grešaka pri funkcionisanju.





Ciljna grupa

Ovaj dokument je upućen tehničkim stručnjacima u skladu sa EN IEC 62079:2001.

Upotreba sa namerom

HyTouch uređaj za upravljanje pisoarom je namenjen za ispiranje keramike za pisoar. Proizvođač isključuje garantne zahteve i odgovornost za bilo kakve povrede ili oštećenja materijala do kojih je došlo usled upotrebe koja odstupa od svrhe uređaja.

Objašnjenje simbola

Simbol	Značenje
 PAŽNJA	Ukazuje na moguću opasnu situaciju, koja lako može dovesti do lakše povrede ili oštećenja materijala.
	Upotrebljavati mast za podmazivanje!
	Voda iz vodovoda je isključena.
	Voda iz vodovoda je uključena.

SR

Kontakt

Ako imate pitanja ili probleme, obratite se nadležnoj Geberitovoj prodajnoj firmi u svojoj zemlji ili samoj kompaniji preko njene internet strane www.geberit.com.

Struktura

HyTouch uređaj za upravljanje pisoarom – pneumatika

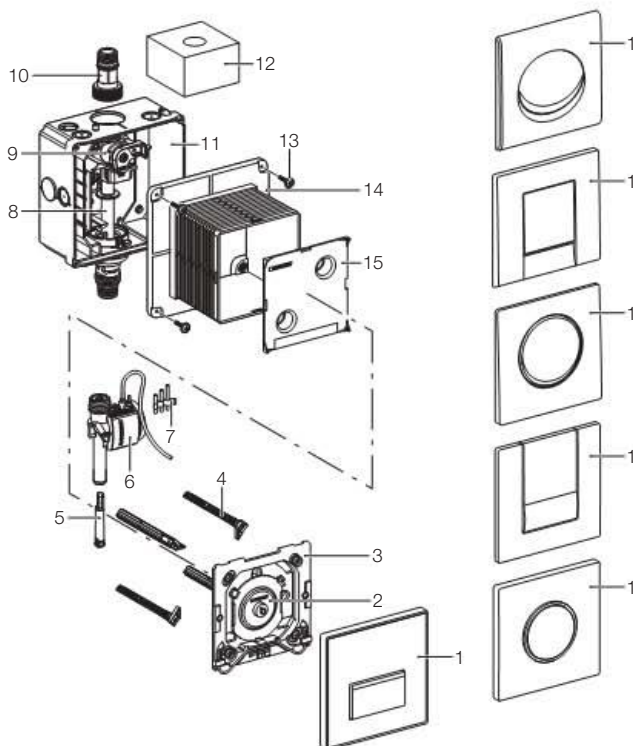

- 1 Tipka za aktiviranje
- 2 Pneumatski pritiskač
- 3 Montažni okvir
- 4 Vijak za razmak
- 5 Ograničavač protoka
- 6 Pneumatski ventil
- 7 Umetak mlaznice
- 8 Prazna cev
- 9 Zaporni ventil sa prigušnicom
- 10 Nipl
- 11 Ugradno kućište
- 12 Zaštitni sunđer
- 13 Šraf za pričvršćenje
- 14 Zaštitni poklopac
- 15 Poklopac zaštitne kutije

Održavanje

Servisni interval

Sledeće radove na održavanju obavljati po potrebi, ali najkasnije na isteku propisanog vremenskog intervala:

- Čišćenje tipke za aktiviranje – operator, jednom nedeljno
- Čišćenje korpe filtera – svake 2 godine, tehnički stručnjak

Rad na održavanju

Čišćenje tastera



PAŽNJA

Agresivna i abrazivna sredstva za čišćenje mogu da oštete površinu.

- ▶ Izbegavati sredstva za čišćenje i ribanje na bazi hlora i kiseline, koja mogu da nagrizu površinu. Koristiti isključivo blaga sredstva za čišćenje i vodu



Reklamacije, koje su posledica nestručne upotrebe sredstava za čišćenje, ne mogu da budu prihvaćene.

Očistiti ili zameniti korpasti filter



SR

Usluga

Otklanjanje kvarova

Problem	Mogući uzrok	Pomoć
Voda ne teče	Zatvoren je dovod vode	Otvoriti dovod vode
	Korpasti filter je blokiran ili zagađen	Očistiti ili zameniti korpasti filter • Pogledajte „Održavanje, očistiti ili zameniti korpasti filter”
	Nema pritiska u vodovodnoj mreži	Proveriti pritisak vode • Vra tite pritisak vode na normalan nivo
	Izvađena je utičnica pneumatskog creva između pneumatskog tastera i pneumatskog ventila	Spojiti utičnicu pneumatskog creva
	Pneumatsko crevo je uvrnuto ili polomljeno	Zameniti pogrešno pneumatsko crevo
Nekontrolisano tečenje (Voda ne prestaje da teče)	Pneumatski ventil je pogrešan	Zameniti pneumatski ventil • Pogledajte poglavlje „Usluga, zamena pneumatskog ventila”
	Pneumatski ventil je pogrešan	Zameniti pneumatski ventil • Pogledajte poglavlje „Usluga, zamena pneumatskog ventila”
Keramika za pisoar nije dovoljno isprana	Prigušnica nije dovoljno otvorena	Otvoriti prigušnicu
Voda prska iz keramike za pisoar	Prevelik protok	Montirati ograničavač protoka • Ograničavač protoka je moguće nabaviti kao pribor (242.484.00.1)

Servis

U ovom uputstvu za servisiranje prikazano je upravljanje sa vertikalnim protokom vode (A). Nije prikazano upravljanje sa horizontalnim protokom vode, ali se servis obavlja na isti način.

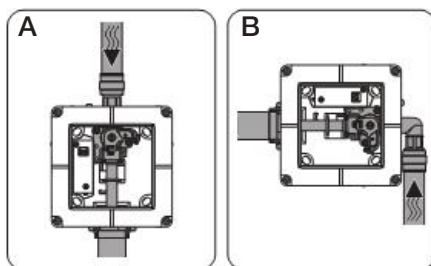

Ovde je opisan sledeći servis:

- Demontirati tipku za aktiviranje i montažni okvir
- Zameniti pneumatski ventil
- Zameniti šraf za regulaciju
- Zameniti zapivnu gumu na dovodu za ispiranje
- Montirati montažni okvir i tipku za aktiviranje

Demontaža tastera i okvira za pričvršćivanje

1

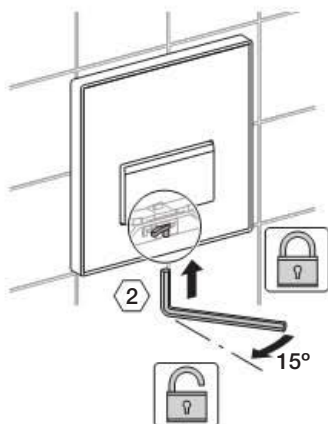

2

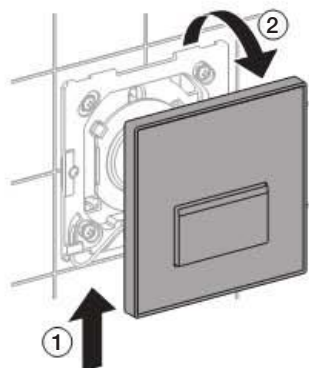

3

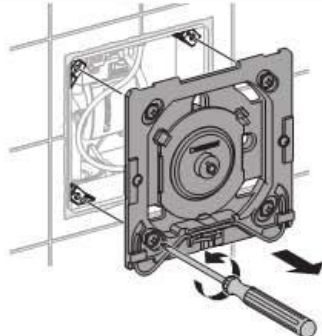

4

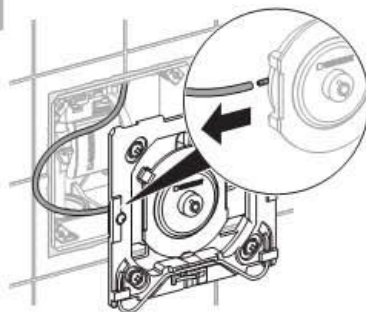

Zameniti pneumatski ventil

Preduslovi

Tipka za aktiviranje i montažni okvir su demontirani.

Pogleda i poglavlje „Usluga, demontaža ipke za aktiviranje i montažnog okvira”.

1

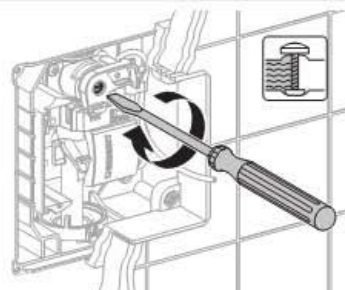

2

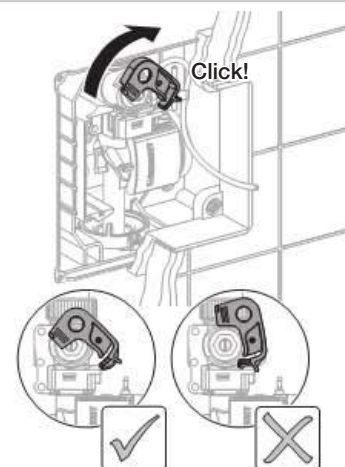

SR

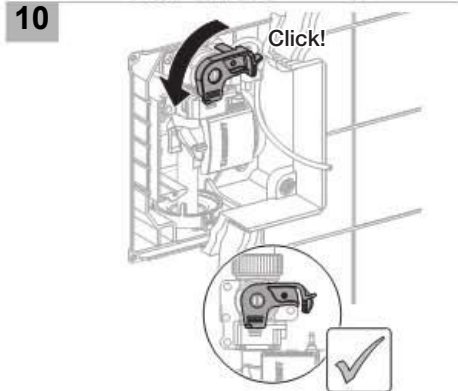
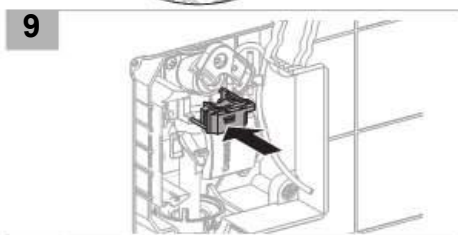
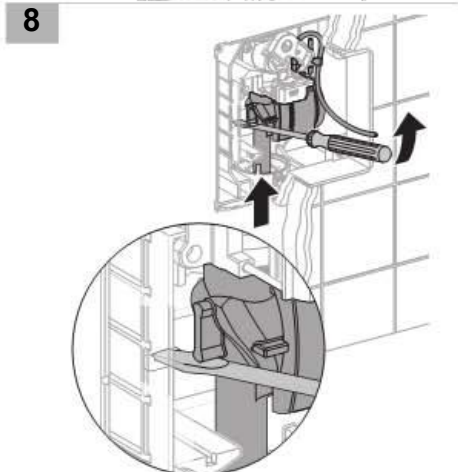
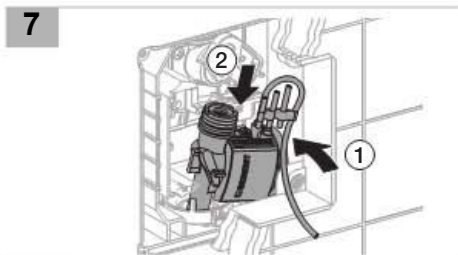
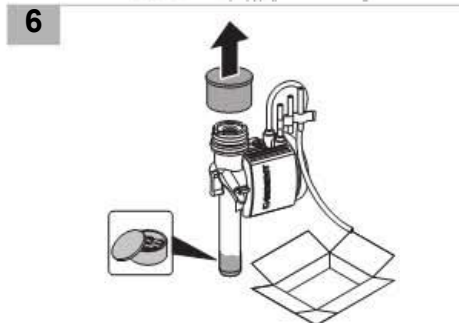
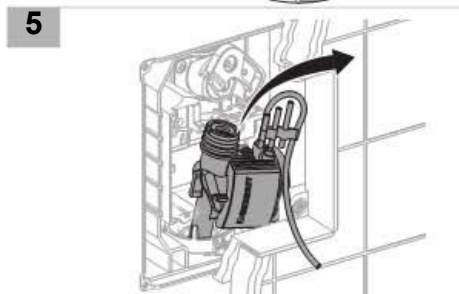
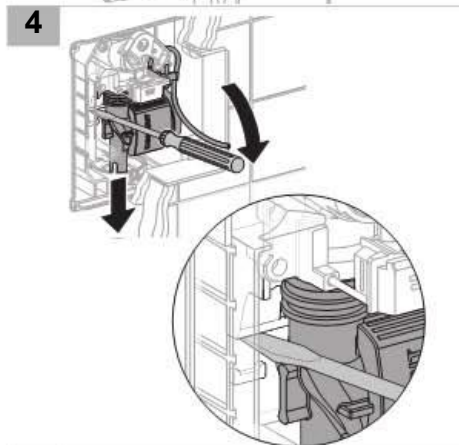
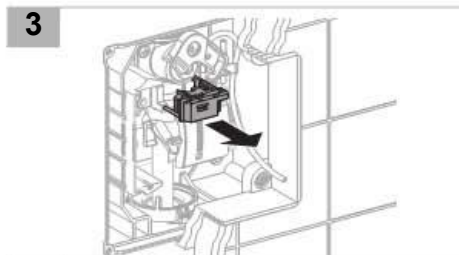

Zameniti šraf za regulaciju

Preduслови

Tipka za aktiviranje i montažni okvir su demontirani.

Pogledati poglavlje „Usluga, demontaža tipke za aktiviranje i montažnog okvira“.

1

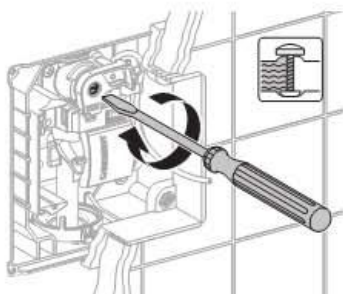

2 Zatvorite centralni dovod vode.

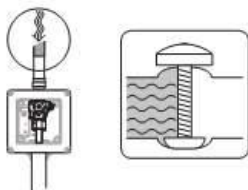

3

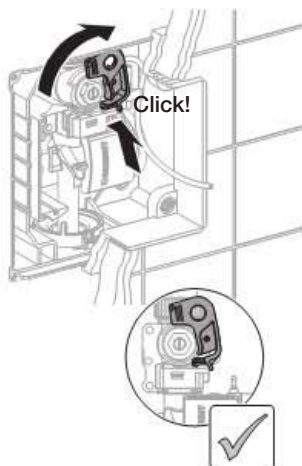

4

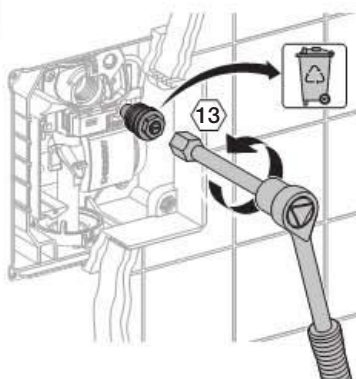

5

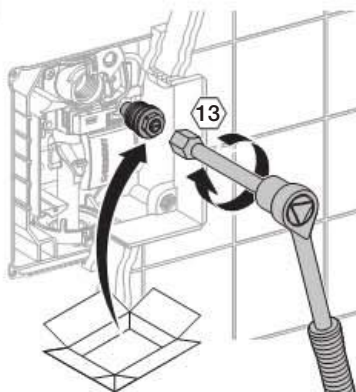

6

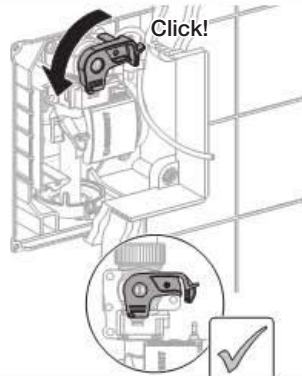

7 Otvorite centralni dovod vode.



Zameniti zaptivnu gumu na dovodu za ispiranje

Preduslovi

Tipka za aktiviranje i montažni okvir su demontrani.

Pogledati poglavlje „Usluga, demontaža tipke za aktiviranje i montažnog okvira“.

1

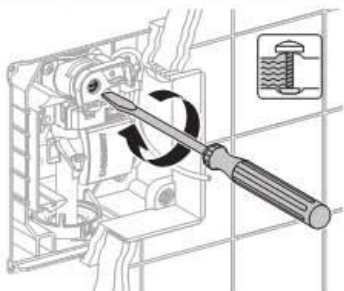

2

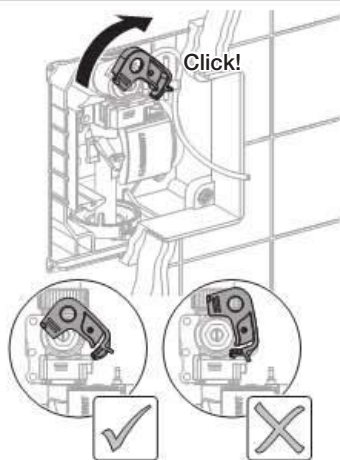

3

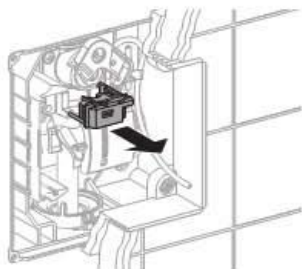

4

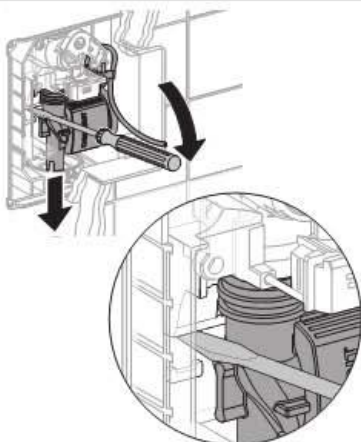

5

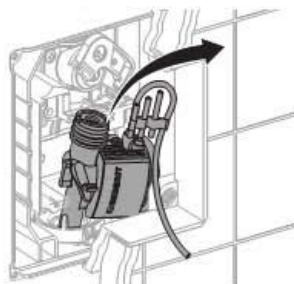

6

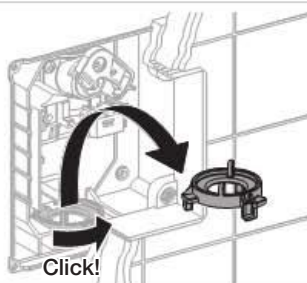

7

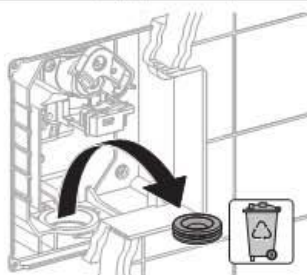

8



9



10

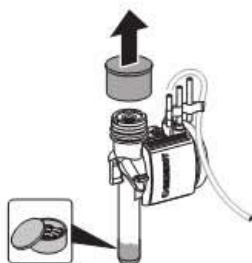

11

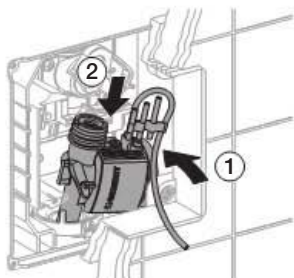

12

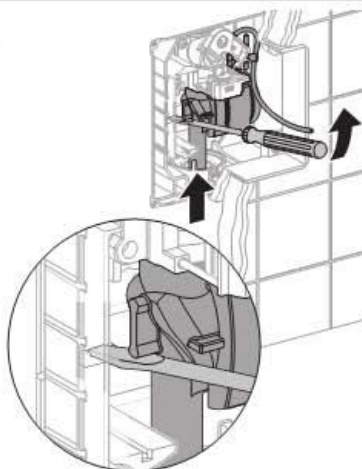

13

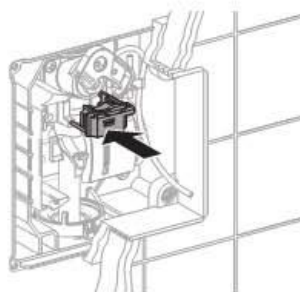

14

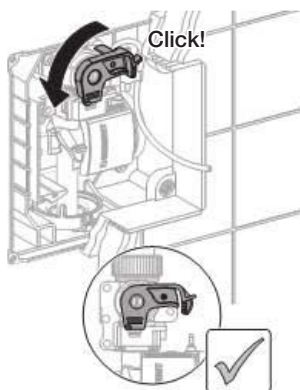

SR

Montirati montažni okvir i tipku za aktiviranje

1

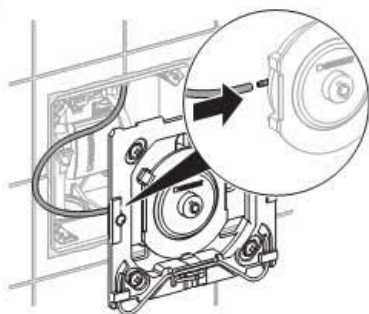

2

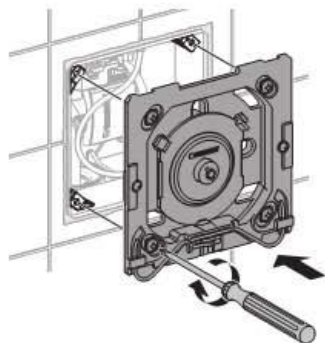

3

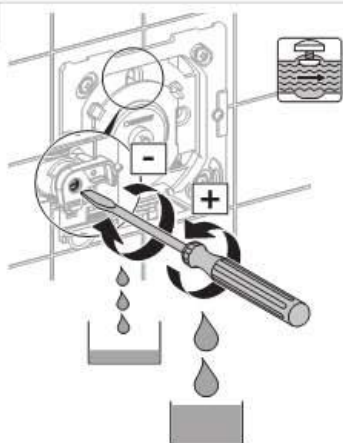

4

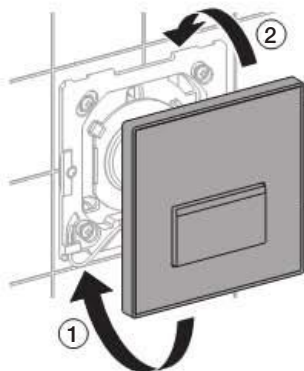

5

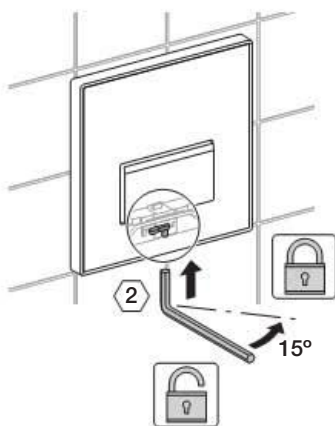

Tehnički podaci

HyTouch uređaj za upravljanje pisoarom – pneumatika

Protok vode pod pritiskom od 1 bara	0,3 / 0,24 (sa ograničavačem protoka) l/s
Kontrolni pritisak vode	16 bara
Kontrolni pritisak / inertni gas	3 bara
Sila aktiviranja	< 12 N
Vreme ispiranja - opseg podešavanja	4 / 8 / 12 s
Vlažnost vazduha	< 100 % relativna
Opseg pritiska prilikom rada	1 - 8 bara
Radna temperatura vode maks.	30 s

SR

Üldised märkused





Käesolev kasutusjuhend	Kasutusjuhend alles hoida ja vajadusel võimaldada spetsialistil sellega tutvuda.
Kasutamine, hooldus	Hooldustöid tohib käitaja teostada vaid käesolevas juhendis kirjeldatud ulatuses.
Teenindus	Teenindustöid tohivad teostada ainult spetsialistid. Tööde mitte-nõuetekohane teostamine võib põhjustada õnnetusi, materiaalseid kahjusid ja talitushäireid.
Sihtgrupp	

Käesolev dokument on suunatud spetsialistidele vastavalt standardile EN IEC 62079:2001.

Eesmärgipärane kasutamine

HyTouch pissuaari loputusregulaatorid on ette nähtud pissuaaripoti loputamiseks. Ebaõige kasutuse korral on garantiinõuded ja vastutusnõuded inimeste vigastuste ja materiaalsest kahjustuse osas välistatud.

Sümbolite seletus

Sümbol	Tähendus
	ETTEVAATUST Juhib tähelepanu võimalikule ohtlikule olukorrale, mis võib põhjustada kergeid või keskmise raskusega kehavigastusi või materiaalseid kahjusid.
	Kasutada määrdeõli!
	Kraanivesi on kinni keeratud
	Kraanivesi on lahti keeratud

EE

Kontakt

Küsimuste korral või probleemide ilmnemisel võtke ühendust lähima Geberiti volitatud edasimüüjaga või vaadake www.geberit.com.

Ehitus

HyTouch pissuaari loputusregulaatori pneumaatika

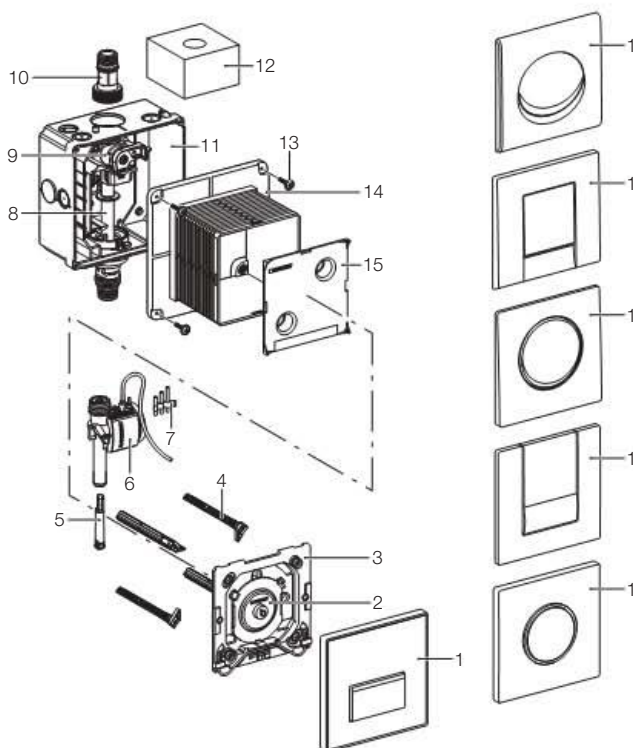

- 1 Lülitusplaat
- 2 Pneumaatiline lüliti
- 3 Kinnitusraam
- 4 Distantspolt
- 5 Läbivoolupiirik
- 6 Pneumoventiil
- 7 Düüsikomplekt
- 8 Tühitoru
- 9 Drossel-sulgventiil
- 10 Ühendusnippel
- 11 Krohvi alla paigaldatav korpus
- 12 Kaitsesvamm
- 13 Kinnituskruvid
- 14 Kaitseümbris
- 15 Kaitseümbrise kaas

Hooldus

Hooldusvälp

Vastavalt vajadusele kuid hiljemalt antud ajavahemikus tuleb teha järgnevat hooldustööd:

- Lülitusplaadi pealispinna puhastamine – kord nädalas, valdaja poolt
- Korvfiltri puhastamine – iga 2 aasta tagant, spetsialisti poolt

Hooldustööd

Lülitusplaadi puhastamine

ETTEVAATUST
 Agressiivsed ja küürivad puhastusvahendid võivad pealispinda kahjustada.

- ▶ Mitte kasutada kloori- või happesisaldusega, lihivaid või söövitavaid puhastusvahendeid, kasutada ainult õrnu puhastusvahendeid ja vett

i Me ei saa aktsepteerida kaebuseid, mis on põhjustatud puhastusvahendite valest kasutamisest.

Korvfiltri puhastamine või asendamine



EE

Teenindus

Veaotsing

Probleem	Võimalik põhjus	Abinõu
Vett ei tule	Veevarustus on suletud	Veevarustuse avamine
	Korvfilter on ummistunud või määrdunud	Korvfiltri puhastamine või asendamine • Vt "Hooldus, korvfiltri puhastamine või asendamine"
	Veevõrgus puudub surve	Veesurve kontrollimine • Taastada veesurve
	Pneumolüliti ja pneuvoventiili vahelise pneumovooliku liitmik on katkenud	Pneumovooliku liitmiku ühendamine
	Pneumovoolik on kokku muljutud või katki	Defektse pneumovooliku väljavahetamine
Pidev veevool (veevool ei lakka)	Pneuvoventiil on defektne	Pneuvoventiili asendamine • Vt "Teenindus, pneuvoventiili asendamine"
	Pissuaaripoti ebapiisav loputus	Drosseli avamine
Pissuaaripotist pritsib loputusvett	Läbivool on liiga suur	Läbivoolupiiriku paigaldamine • Läbivoolupiirik on saadaval lisatarvikuna (242.484.00.1)

Teenindustööd

Käesolevas teenindusjuhendis on näiteks toodud vertikaalse veevooluga regulaator (A). Horisontaalse veevooluga regulaatoreid (B) ei ole siin näidatud, kuid teenindustööd on samad.

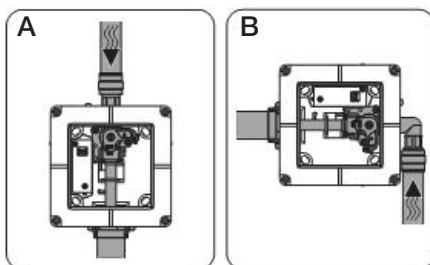

Siinkohal kirjeldatakse allpool loetletud teenindustöid.

- Lülitusplaadi ja kinnusraami demonteerimine
- Pneuvoventiili asendamine
- Drosselkrui asendamine
- Lopustorustiku huultihendi asendamine
- Kinnusraami ja lülitusplaadi paigaldamine

Lülitusplaadi ja kinnitusraami demonteerimine

1

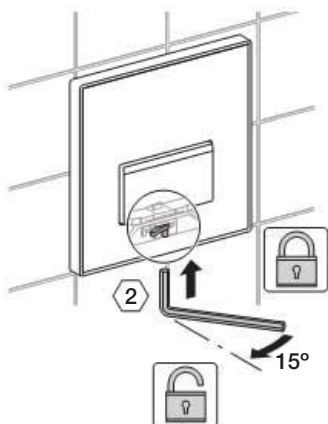

2

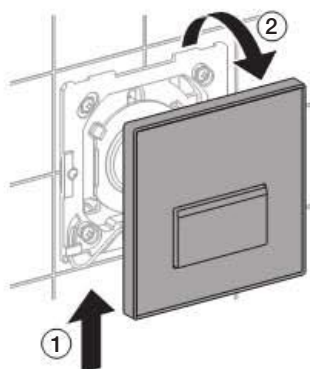

3

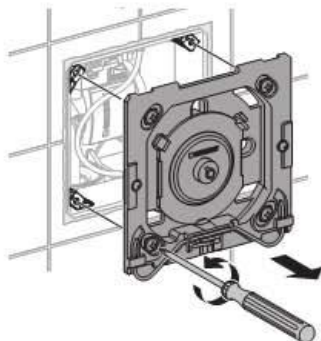

4

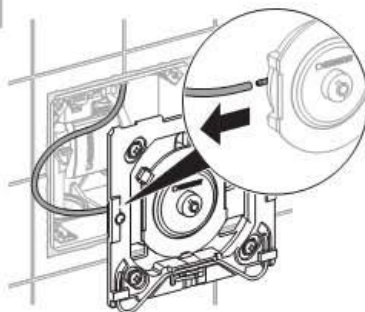

Pneumoventiili asendamine

Eeldused

Lülitusplaat ja kinnitusraam on eemaldatud. Vt "Teenindus, lülitusplaadi ja kinnitusraami demonteerimine".

1

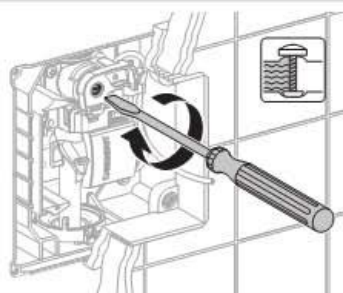

2

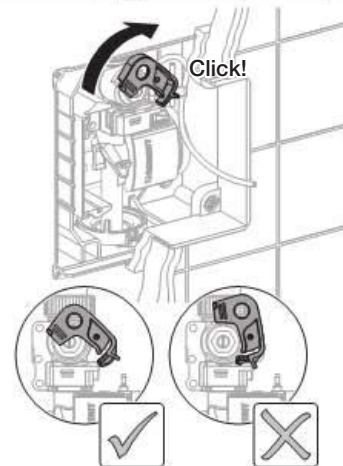

EE

3

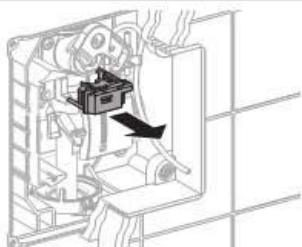

4

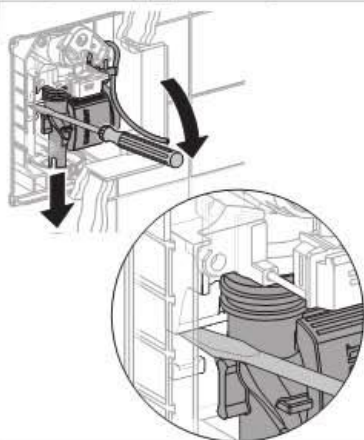

5

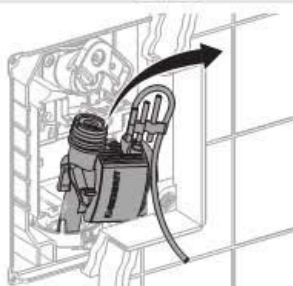

6

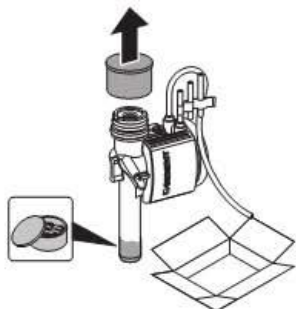

7

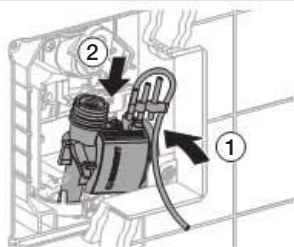

8

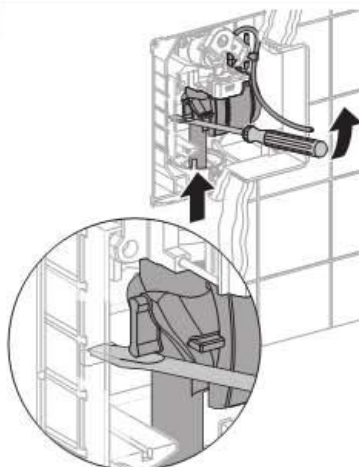

9

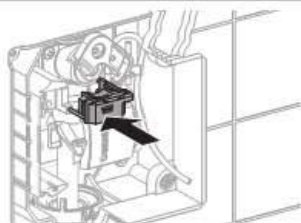

10

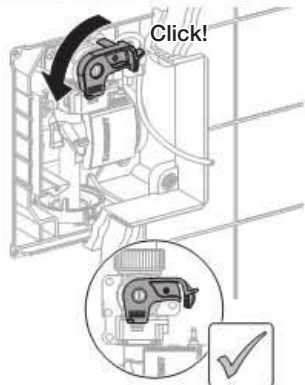

Drosselkruvi asendamine**Eeldused**

Lülitusplaat ja kinnusraam on eemaldatud.
Vt "Teenindus, lülitusplaadi ja kinnusraami demonteerimine".

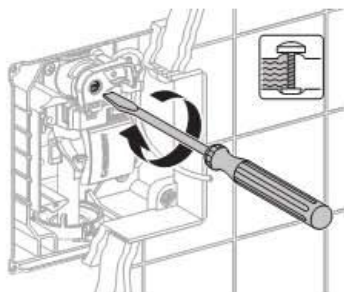
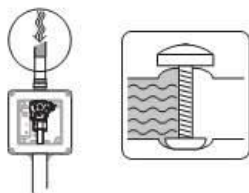
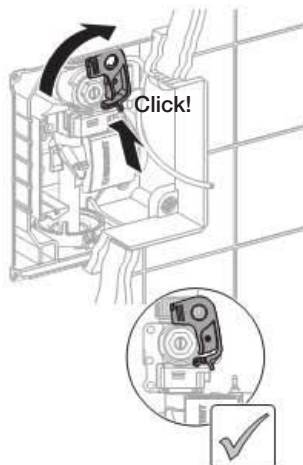
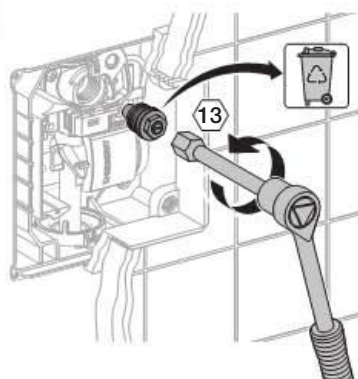
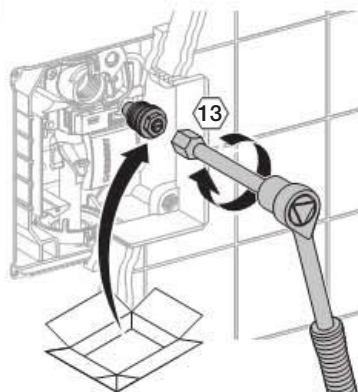
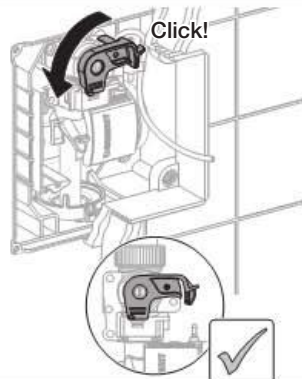
1**2** Sulgeda tsentraalne veevarustus.**3****4****5****6****7** Avada tsentraalne veevarustus.

Loputustorustiku huultihendi asendamine

Eeldused

Lülitisplaat ja kinnitusraam on eemaldatud.
Vt "Teenindus, lülitisplaadi ja kinnitusraami demonteerimine".

1

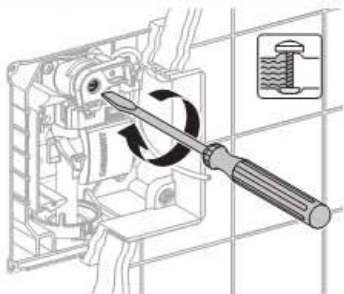

2

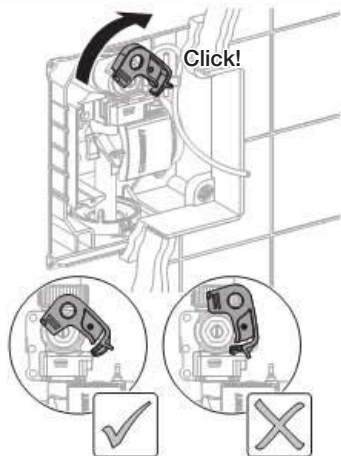

3

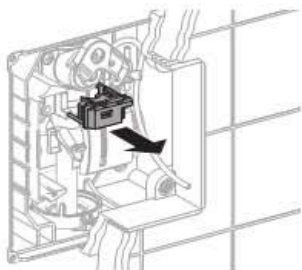

4

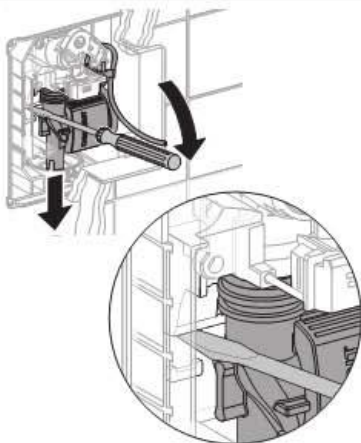

5

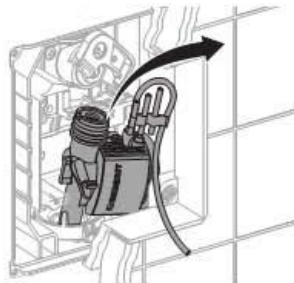

6

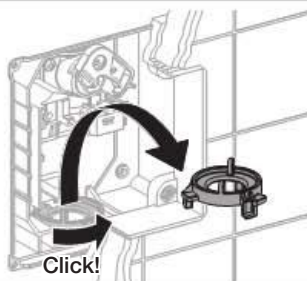

7

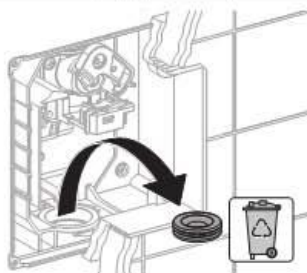

8



9

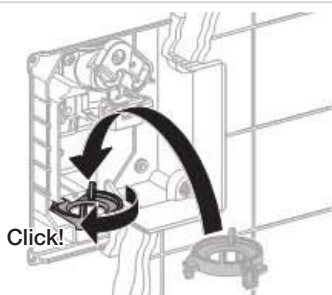

10

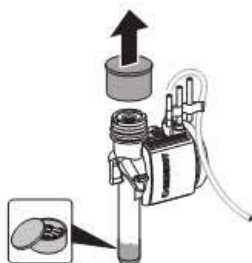

11

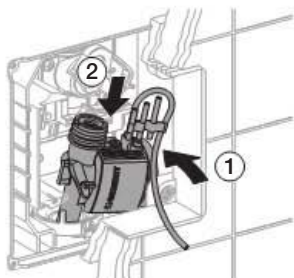

12

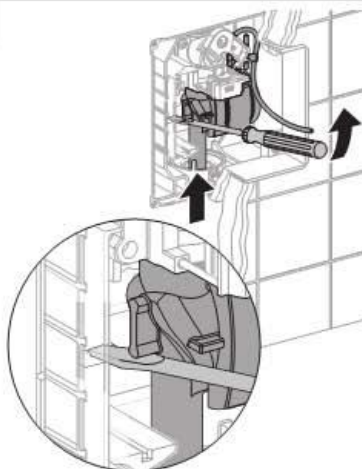

13

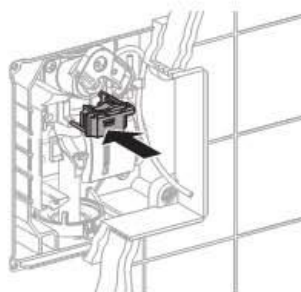

14

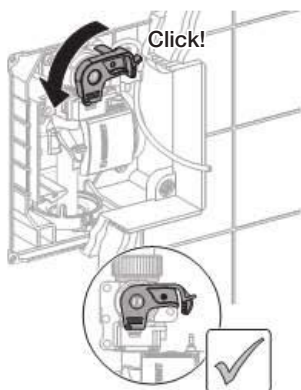

EE

Kinnitusraami ja lülitusplaadi paigaldamine

1

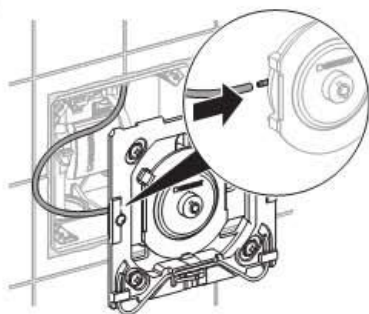

2

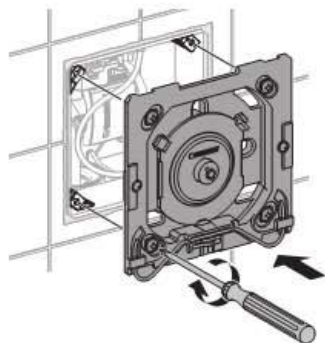

3

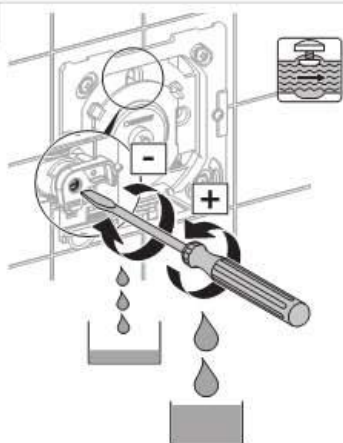

4

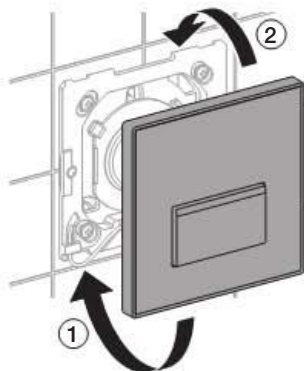

5

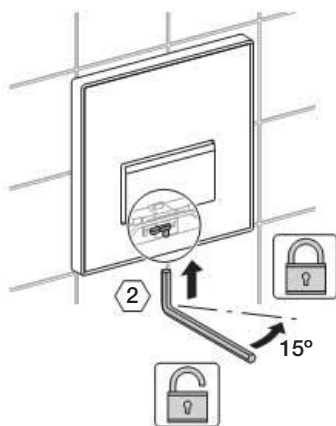

Tehnilised andmed

HyTouch pissuaari loputusregulaatori pneumaatika

Voolukiirus 1 bar juures	0,3 / 0,24 (läbivoolupiirikuga) l/s
Vee kontrollrõhk	16 bar
Õhu / inertsgaasi kontrollrõhk	3 bar
Rakendusjõud	< 12 N
Loputusaja seadevahemik	4 / 8 / 12 s
Õhuniiskus	< 100 Suhteline, %-des
Rõhuvahemik töötamisel	1 - 8 bar
Vee max töötemperatuur	30 °C

Vispārīgas piezīmes

Šī ekspluatācijas instrukcija

Ekspluatācijas instrukciju uzglabāt un nepieciešamības gadījumā nodot speciālistam.

Ekspluatācija un tehniskā apkope

Lietotājs drīkst veikt tehnisko apkopi tikai šajā instrukcijā paredzētajā apmērā.

Apkope

Apkopes darbu veikšana ir jāuztic speciālistam. Nepareizi lietojot vadības sistēmu var notikt negadījumi, rasties bojājumi un darbības traucējumi.





Mērķa grupa

Šis dokuments paredzēts speciālistiem saskaņā ar EN IEC 62079:2001.

Lietošana saskaņā ar noteikumiem

HyTouch pisuāru vadības sistēmas ir paredzētas pisuāru skalošanai. Nepareizi lietojot vadības sistēmu, garantijas laikā iesniegtās pretenzijas traumu vai materiālo zaudējumu gadījumā netiks pieņemtas.

Simbolu izskaidrojums

Simbols	Nozīme
	UZMANĪBU Norāda iespējamu bīstamu situāciju, kuras rezultātā var gūt vieglas vai vidēji smagas ķermeņa traumas vai var rasties materiāli zaudējumi.
	Izmantot smērvielu!
	Ūdensvada padeve ir atvienota
	Ūdensvada padeve ir pievienota

Kontakti

Jautājumu vai problēmu gadījumā sazinieties ar atbildīgo Geberit produkcijas izplatītāju vai ielūkojieties interneta mājas lapā www.geberit.com.

Uzbūve

HyTouch pneimatiskā pusuāra vadības sistēma

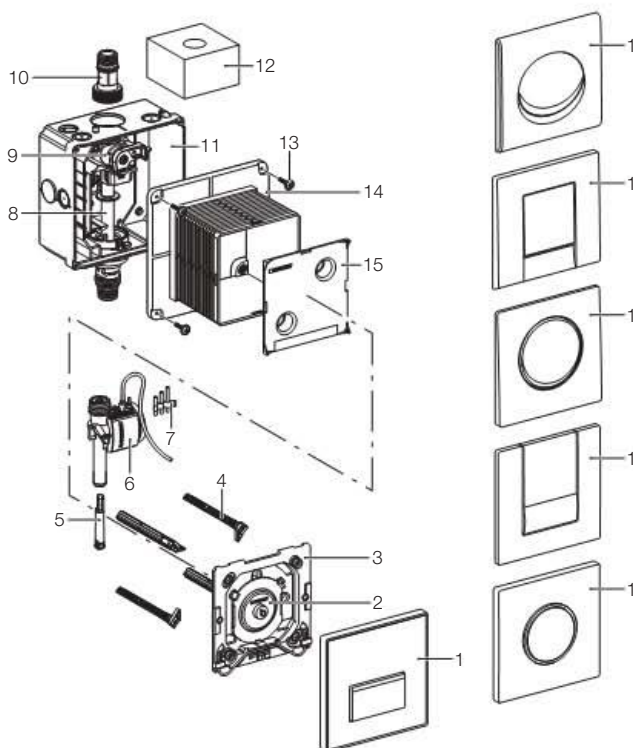

- 1 Taustiņa plāksne
- 2 Pneimatiskais piespiedējs
- 3 Stiprinājuma rāmis
- 4 Iestāšanās tapas
- 5 Caurteces ierobežotājs
- 6 Pneimatiskais ventilis
- 7 Sprauslu komplekts
- 8 Aizsargcaurule
- 9 Noslēgventilis ar droseli
- 10 Pieslēguma nipelis
- 11 Zemapmetuma korpuss
- 12 Aizsargsūklis
- 13 Stiprinājuma skrūves
- 14 Celtniecības plātne
- 15 Celtniecības plātnes vāks

Tehniskā apkope

Tehniskās apkopes intervāli

Nepieciešamības gadījumā, bet ne vēlāk kā norādītajos intervālos, ir jāveic sekojoši darbi:

- Taustiņa plāksnes virsmas tīrīšana - katru nedēļu, veic lietotājs
- Groza filtra tīrīšana - ik pēc 2 gadiem, veic speciālists

Tehniskās apkopes darbi

Tīrīt taustiņa plāksni



UZMANĪBU

Agresīvi un skrāpējoši tīrīšanas līdzekļi var sabojāt virsmu.

- ▶ Nelietot hlora saturošus, skābes saturošus, abrazīvus vai kodinošus tīrīšanas līdzekļus, bet tikai maigus tīrīšanas līdzekļus un ūdeni



Sūdzības par bojājumiem, kas radušies, lietojot nea bilstošus tīrīšanas līdzekļus, var tikt ņemtas vērā.

Notīrīt vai nomainīt groza filtru



Apkope

Bojājumu meklēšana

Problēma	Iespējamais cēlonis	Novēršana
Ūdens netek	Ūdens padeve ir slēgta	Atvērt ūdens padevi
	Groza filtrs ir aizsērējis vai piesārņots	Notīrīt vai nomainīt groza filtru • Skatīt sadaļu "Tehniskā apkope, groza filtra tīrīšana vai nomainīšana"
	Ūdens tīklā nav spiediena	Pārbaudīt ūdens spiedienu • Atjaunot ūdens spiedienu
	Atvienots pneimatiskās caurules kontaktsavienojums starp pneimatisko piespiedēju un pneimatisko ventili	Savienot pneimatiskās caurules kontaktsavienojumu
	Pneimatiskā caurule ir ieliekta vai salauzta	Nomainīt bojāto pneimatisko cauruli
Ūdens tek pastāvīgi (ūdens nepārstāj tecēt)	Pneimatiskais ventilis ir bojāts	Nomainīt pneimatisko ventili • Skatīt sadaļu "Apkope, pneimatiskā ventija nomainīšana"
	Pneimatiskais ventilis ir bojāts	Nomainīt pneimatisko ventili • Skatīt sadaļu "Apkope, pneimatiskā ventija nomainīšana"
Pisuārs ne iek pietiekami izskalots	Drosele nav pietiekami atvērta	Atvērt droseli
No pisuāra šjakstās skalošanas ūdens	Pārāk liela caurtece	Piemontēt caurteces ierobežotāju • Caurteces ierobežotājs pieejams kā piederums (242.484.00.1)

Apkopes darbi

Šajā remontēšanas instrukcijā ir atainota vadības sistēma ar vertikālu ūdens plūsmu (A). Vadības sistēma ar horizontālu ūdens plūsmu (B) nav atainota, taču apkopes darbi ir identiski.

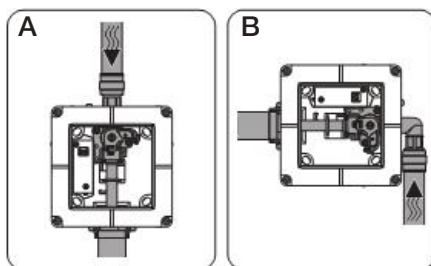

Šeit ir aprakstīti šādi apkopes darbi:

- Taustiņa plāksnes un stiprinājuma rāmja demontāža
- Pneimatiskā ventija nomainīšana
- Droseļskrūves nomainīšana
- Skalošanas caurules manšetbīves nomainīšana
- Stiprinājuma rāmja un taustiņa plāksnes montāža

Taustiņa plāksnes un stiprinājuma rāmja demontāža

1

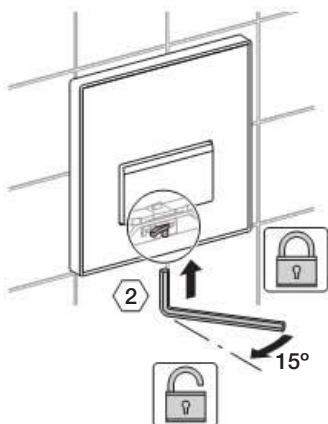

2

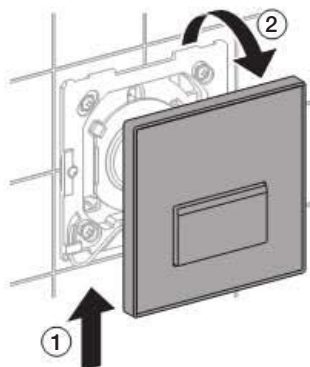

3

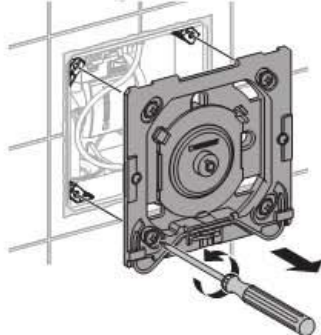

4

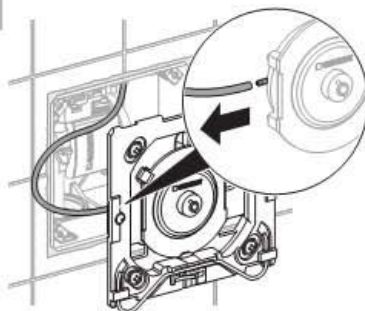

Nomainīt pneimatisko ventili

Priekšnoteikumi

Taustiņa plāksne un stiprinājuma rāmis ir demontēti.

Skatīt sadaļu "Apkope, taustiņa plāksnes un stiprinājuma rāmja demontāža".

1

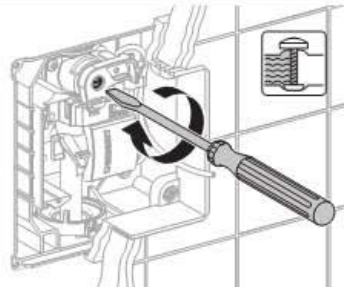

2

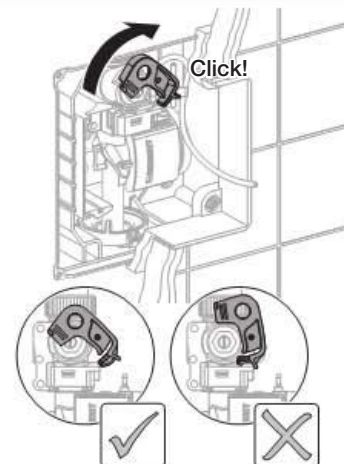

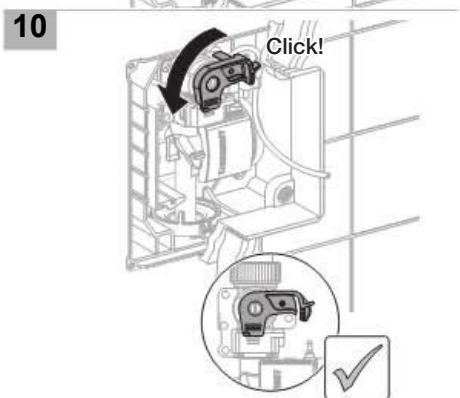
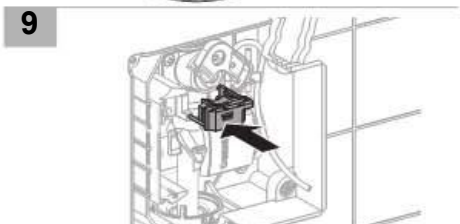
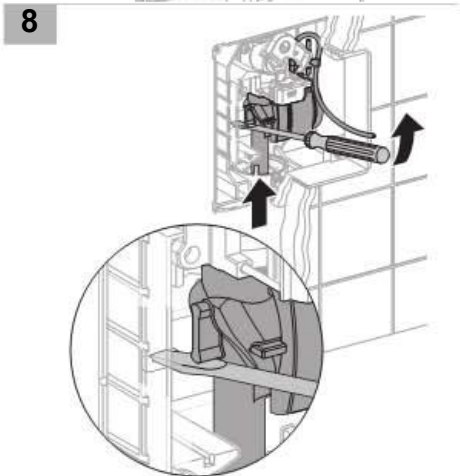
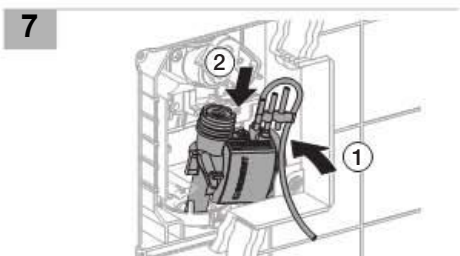
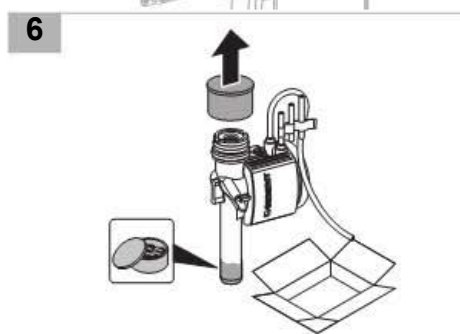
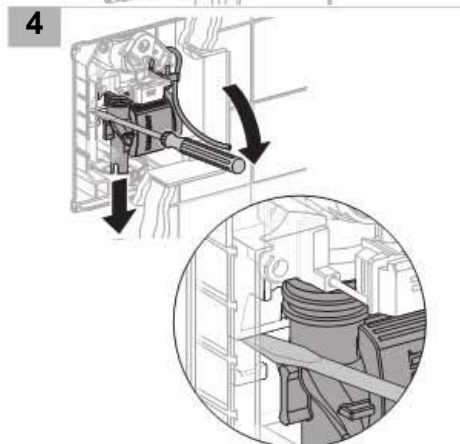
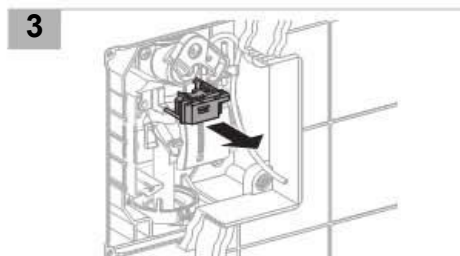

Nomainīt droseļskrūvi

Priekšnoteikumi

Taustiņa plāksne un stiprinājuma rāmis ir demontēti.

Skatīt sadaļu "Apkope, tauts iņa plāksnes un stiprinājuma rāmja demontāža".

1

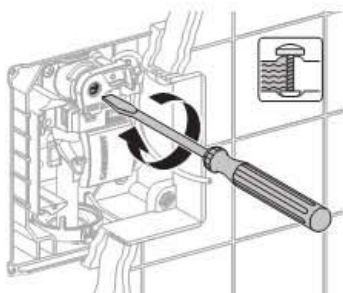

2 Noslēgt centrālo ūdens padevi.

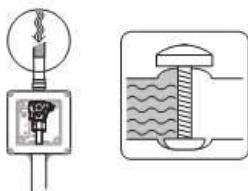

3

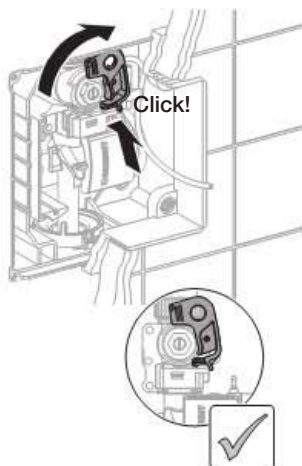

4

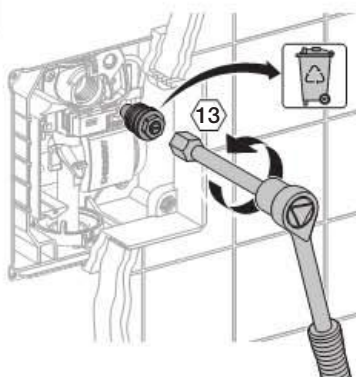

5

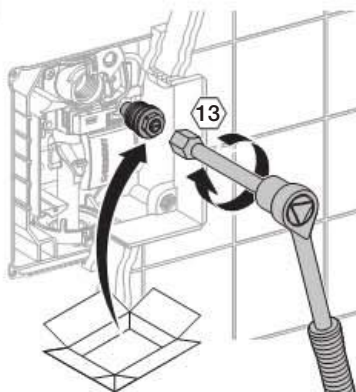

6

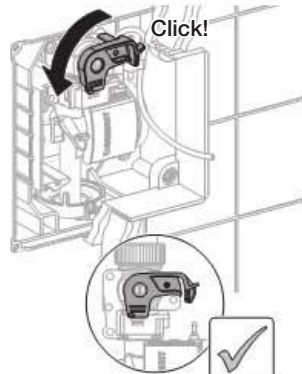

7 Atvērt centrālo ūdens padevi.



Nomainīt skalošanas caurules manšetblīvi

Priekšnoteikumi

Taustiņa plāksne un stiprinājuma rāmis ir demontēti.

Skatīt sadaļu "Apkope, taustiņa plāksnes un stiprinājuma rāmja demontāža".

1

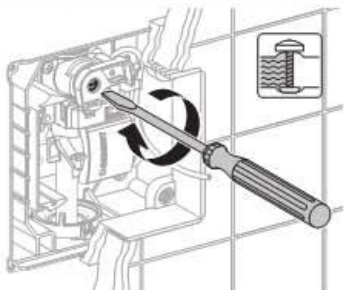

2

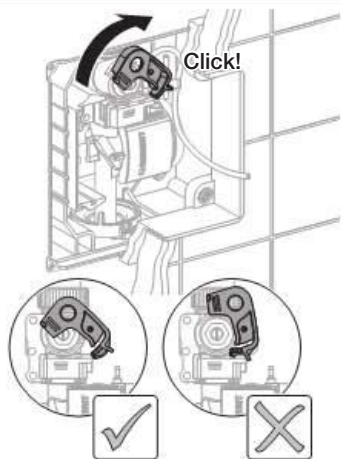

3

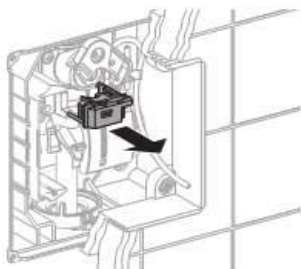

4

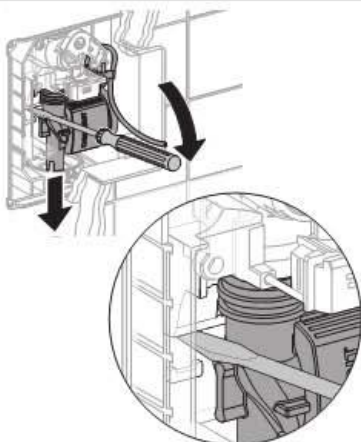

5

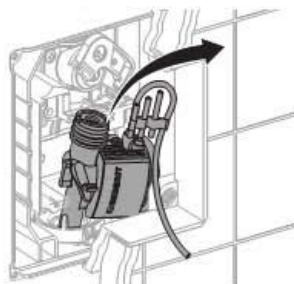

6

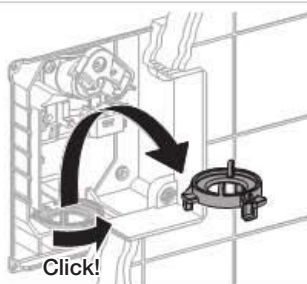

7

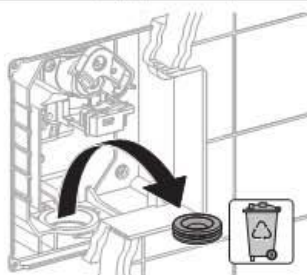

8



9



10

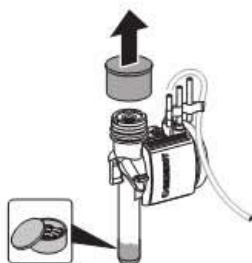

11

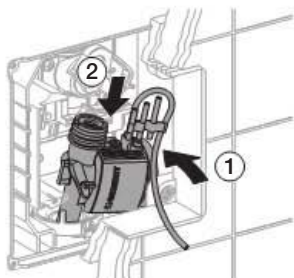

12

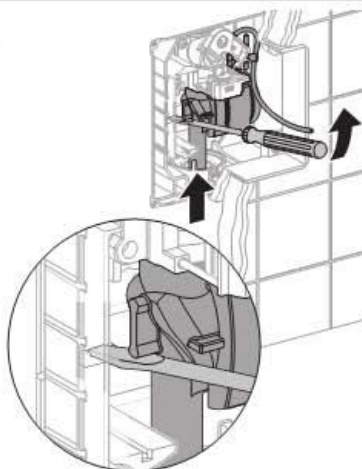

13

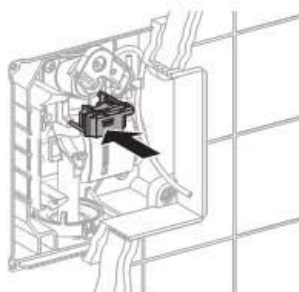

14

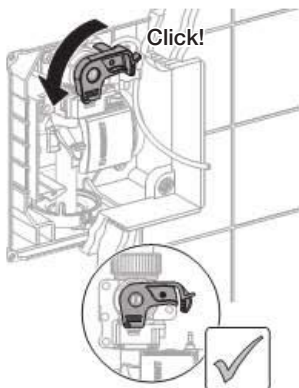

LV

Stiprinājuma rāmja un taustiņa plāksnes montāža

1

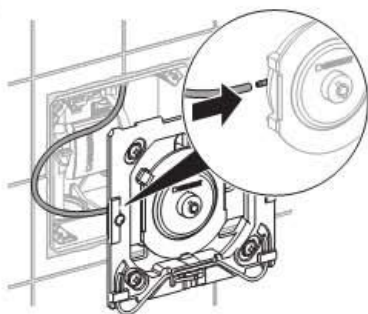

2

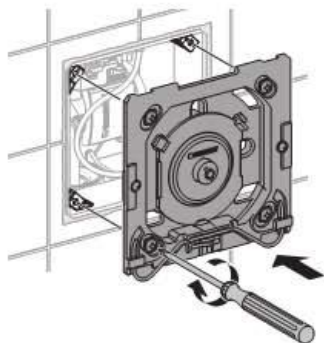

3

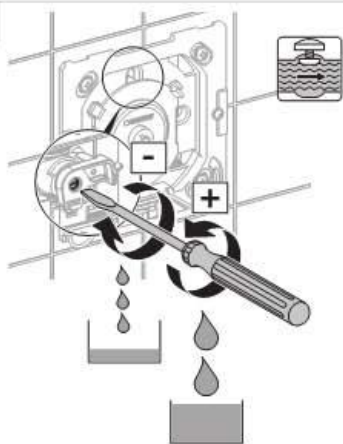

4

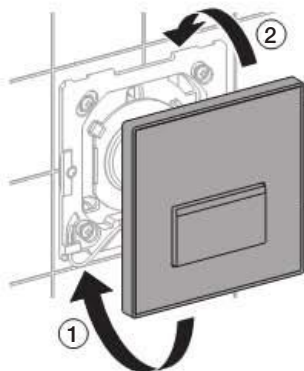

5

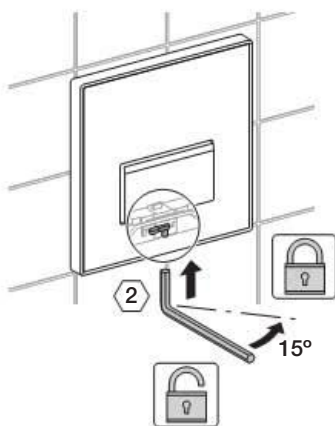

Tehniskie dati

HyTouch pneimatiskā pusuāra vadības sistēma

Caurteces daudzums pie 1 bar	0,3 / 0,24 (ar caurteces ierobežotāju) l/s
Ūdens pārbaudes spiediens	16 bar
Gaisa / inertas gāzes pārbaudes spiediens	3 bar
Darbināšanas spēks	< 12 N
Skalošanas laika iestatīšanas diapazons	4 / 8 / 12 s
Gaisa mitrums	< 100 %, relatīvais
Ekspluatācijas spiediena diapazons	1 - 8 bar
Ūdens maks. temperatūra	30 °C

Bendrosios nuorodos

Ši eksploatacijos instrukcija

Eksploatacijos instrukciją būtina išsaugoti ir prireikus pateikti specialistui.

Eksploatacija, techninė priežiūra

Eksploatuotojas gali atlikti tik tuos techninės priežiūros darbus, kurie aprašyti šioje instrukcijoje.

Techninis aptarnavimas

Techninio aptarnavimo darbus gali atlikti tik specialistas. Netinkamai atlikti darbai gali tapti nelaimingų atsitikimų, materialinių nuostolių ir eksploatacijos sutrikimų priežastimi.





Tikslinė grupė

Šis dokumentas skirtas specialistams pagal EN IEC 62079:2001.

Naudojimas pagal nurodymus

„HyTouch“ pisuaro valdymo sistemos skirtos pisuarų keraminėms dalims skalauti. Jei, naudojant sistemą ne pagal paskirtį, sužalojami asmenys arba patiriama materialinių nuostolių, garantija netenka galios ir gamintojas neprisiima jokios atsakomybės.

Simbolių paaiškinimas

Simbolis	Reikšmė
	DĖMESIO Nurodo galimą pavojingą situaciją, kuri gali tapti lengvo ar vidutinio kūno sužalojimo arba materialinių nuostolių priežastimi.
	Naudoti tepalą!
	Vandentiekio vanduo a jungtas
	Vandentiekio vanduo i jungtas

Kontaktai

Iškilus klausimų ar problemų, kreipkitės į savo atsakingą „Geberit“ produkcijos platinimo įmonę arba internetu www.geberit.com.

LT

Konstrukcija

Pneumatinė „HyTouch“ pisauro valdymo sistemos dalis

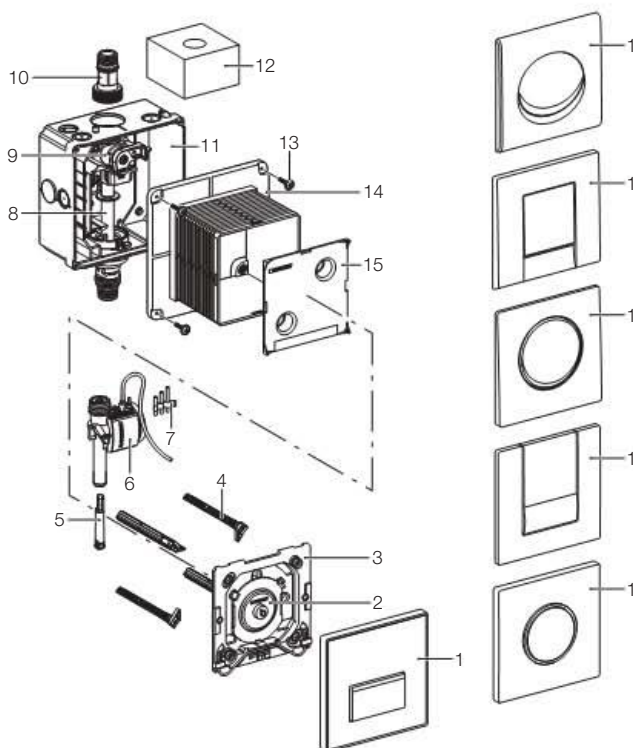

- 1 Darbinė plokštė
- 2 Pneumatinis mygtukas
- 3 Tvirtinimo rėmas
- 4 Rėmo tvirtinimo laikiklis
- 5 Vandens srauto ribotuvas
- 6 Pneumatinis vožtuvas
- 7 Purkštukų rinkinys
- 8 Apsauginė alkūnė
- 9 Uždaromasis vožtuvas su droseline rite
- 10 Sujungimo antgalis
- 11 Potinkinis korpusas
- 12 Apsauginė kempinė
- 13 Tvirtinimo varžtai
- 14 Apsauginė dėžutė
- 15 Apsauginės dėžutės dangtelis

Patikra

Patikros intervalai

Esant būtinybei, bet ne vėliau nurodytų intervalų, būtina atlikti šiuos techninės priežiūros darbus:

- Nuvalyti darbinės plokštės paviršių – kiekvieną savaitę (atlieka eksploatuotojas)
- Nuvalyti krepšio formos filtrą – kas 2 metus (atlieka specialistas)

Techninės priežiūros darbai

Darbinės plokštės valymas

- ⚠ DĖMESIO**
Agresyvios ir šveičiančios valymo priemonės gali pažeisti paviršiaus dangą.
- ▶ Nenaudoti valymo priemonių, kurių sudėtyje yra chloro ar rūgščių, taip pat priemonių, kurios šlifuoja ar ėsdina; naudoti tik švelnias valymo priemones ir vandenį

i Nusiskundimai, susiję su netinkamu valymo priemonių naudojimu, gali būti nesvarstomi.

Išvalyti arba pakeisti krepšio formos filtrą



Techninis aptarnavimas

Gedimo paieška

Problema	Galima priežastis	Priemonės gedimui pašalinti
Nebėga vanduo	Vandens tiekimo vožtuvas uždarytas	Atidarykite vandens tiekimo vožtuvą
	Užsikimšęs arba užsiteršęs krepšio formos filtras	Išvalykite arba pakeiskite krepšio formos filtrą • Žr. skyriuje „Patikra. Krepšio formos filtro valymas arba pakeitimas“
	Vandentiekyje nėra slėgio	Patikrinkite vandens slėgį • Atkurkite vandens slėgį
	Kištukinė pneumatinės žarnos jungtis tarp pneuma inio spaustuvo ir pneumatinio vožtuvo atjungta	Atkurkite kištukinę pneumatinės žarnos jungtį
	Pneumatinė žarna sulenкта arba perlaužta	Pakeiskite apgadintą pneumatinę žarną
Nuolatinis vandens bėgimas (vanduo nenustoja bėgti)	Pneumatinis vožtuvas sugedęs	Pakeiskite pneumatinį vožtuvą • Žr. skyriuje „Techninis aptarnavimas, pneumatinio vožtuvo pakeitimas“
	Per mažai a idaryta droselinė ritė	Atidarykite droselinę ritę
Nepakankamai nuplaunama pisuaro keraminė dalis	Per didelis vandens srautas	Įmontuokite vandens srauto ribotuvą • Vandens srauto ribotuvą galima įsigyti kaip priedą (242.484.00.1)

Techninio aptarnavimo darbai

Šioje taisymo instrukcijoje aprašyta valdymo sistema su vertikaliu vandens tiekimu (A). Valdymo sistema su horizontaliu vandens tiekimu (B) nėra pademonstruota, tačiau techninio aptarnavimo darbai yra tokie patys.

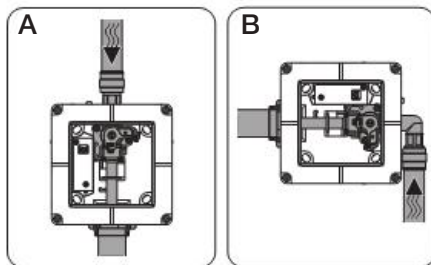

Čia aprašomi šie techninio aptarnavimo darbai:

- Darbinės plokštės ir tvirtinimo rėmo išmontavimas
- Pneuma inio vožtuvo keitimas
- Droselinės ritės varžto keitimas
- Vandens tiekimo sistemos tarpinės keitimas
- Tvirtinimo rėmo ir darbinės plokštės montavimas

Darbinės plokštės ir tvirtinimo rėmo išmontavimas

1

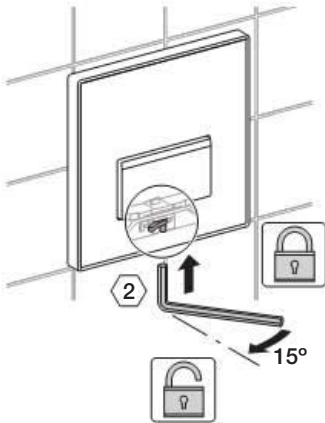

2

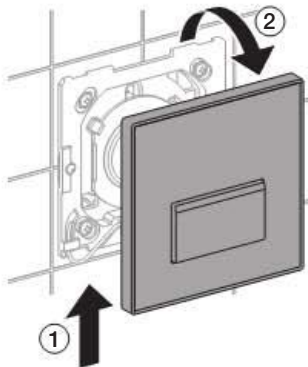

3

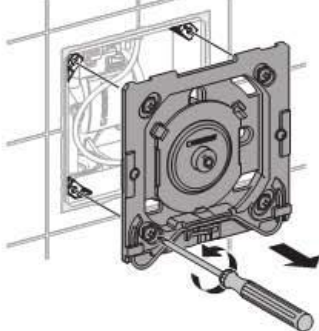

4

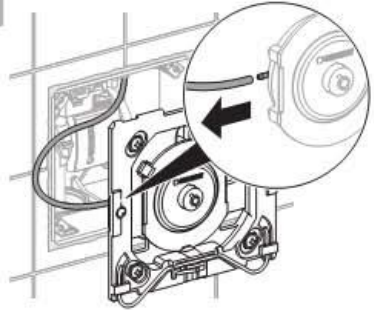

Pakeisti pneumatinį vožtuvą

Sąlygos

Darbinė plokštė ir tvirtinimo rėmas yra išmontuoti.

Žr. skyriuje „Techninis aptarnavimas, darbinės plokštės ir tvirtinimo rėmo išmontavimas“.

1

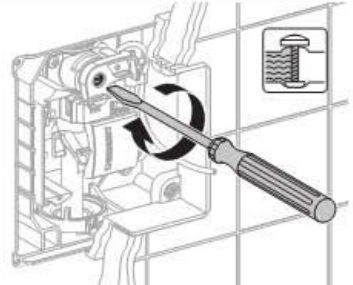

2

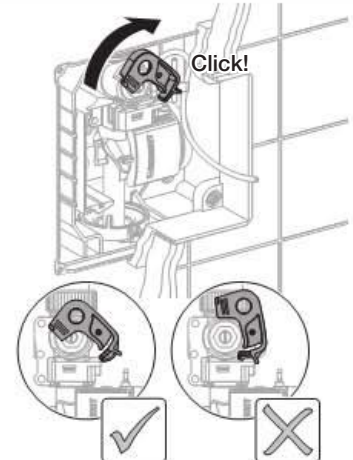

3

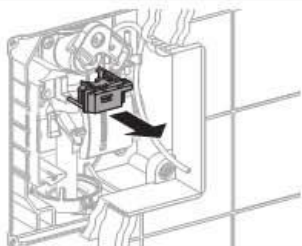

4

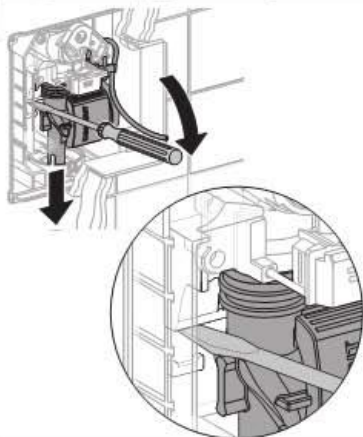

5

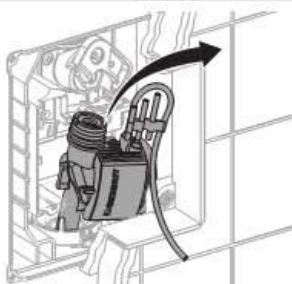

6

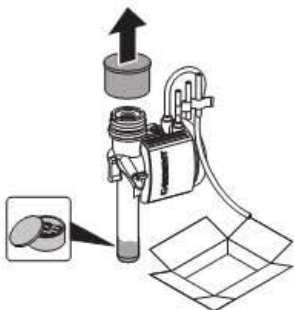

7

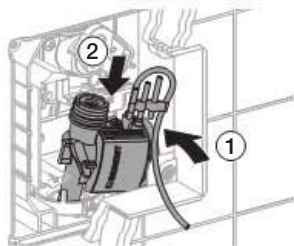

8

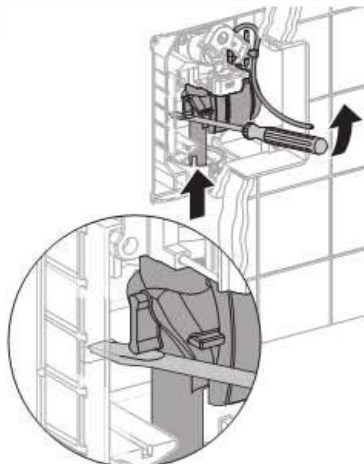

9

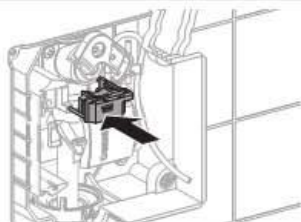

10

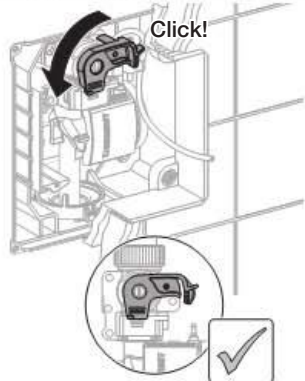

Pakeisti droselinės ritės varžtą

Sąlygos

Darbinė plokštė ir tvirtinimo rėmas yra išmontuoti.

Žr. skyriuje „Techninis aptarnavimas, darbinės plokštės ir tvirtinimo rėmo išmontavimas“.

1

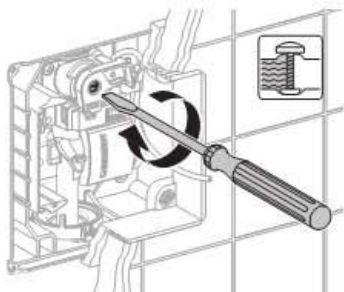

2 Uždarykite pagrindinį vandens tiekimo šaltinį.

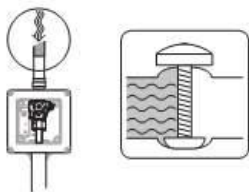

3

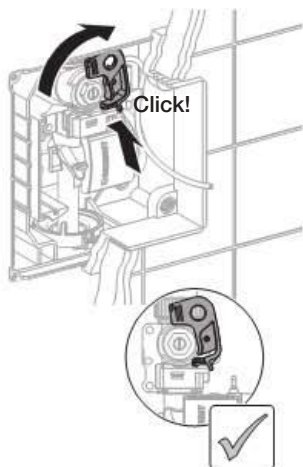

4



5

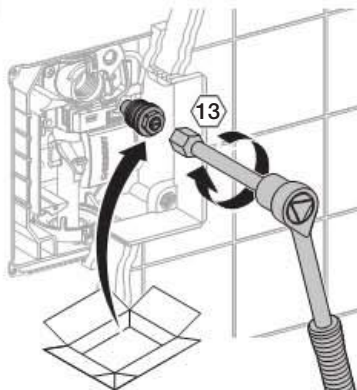

6

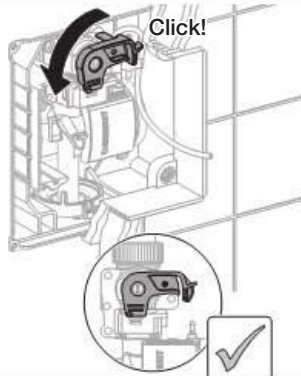

7 Atidarykite pagrindinį vandens tiekimo šaltinį.



Pakeisti vandens tiekimo sistemos tarpinę

Sąlygos

Darbinė plokštė ir tvirtinimo rėmas yra išmontuoti.

Žr. skyriuje „Techninis aptarnavimas, darbinės plokštės ir tvirtinimo rėmo išmontavimas“.

1

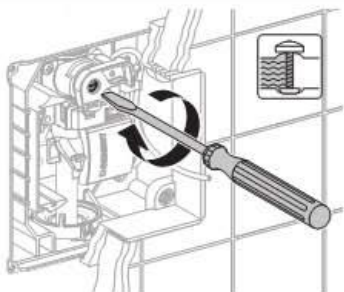

2

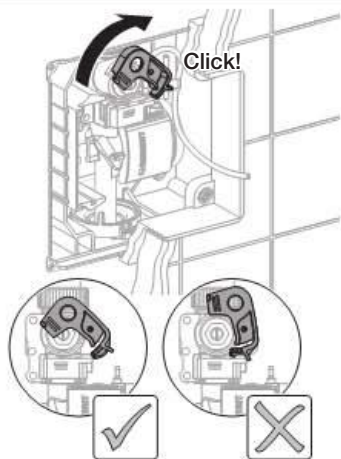

3

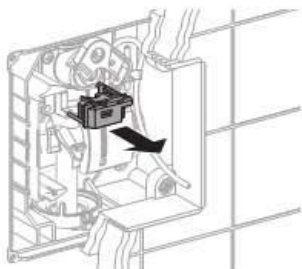

4

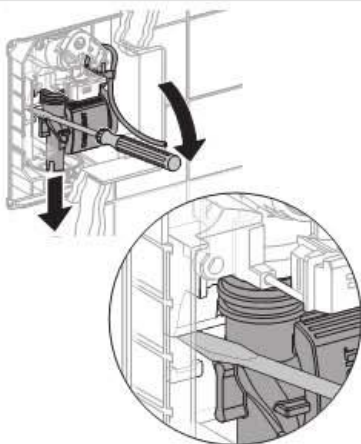

5

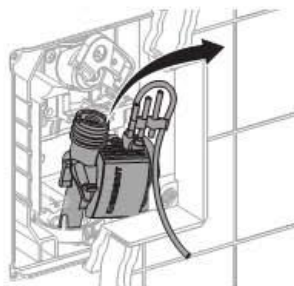

6

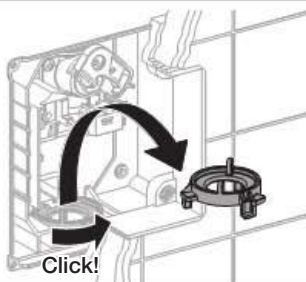

7

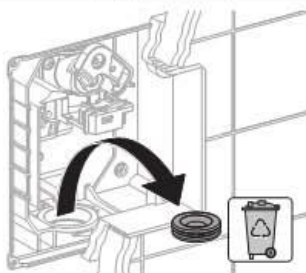

8



9

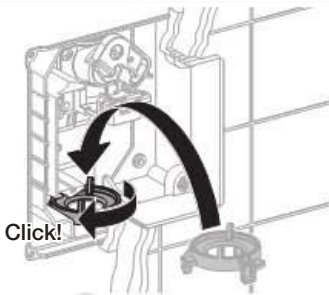

10

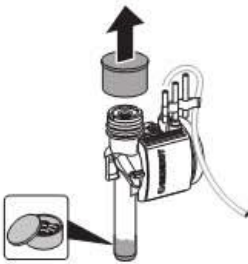

11

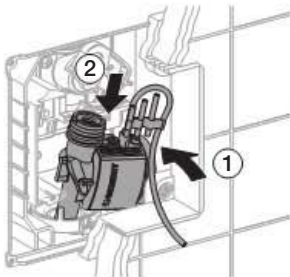

12

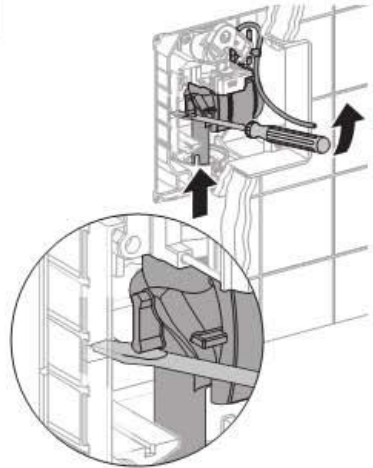

13

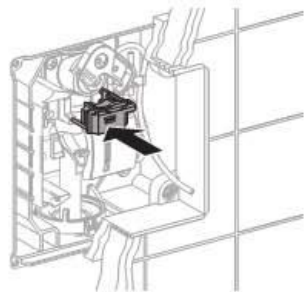

14

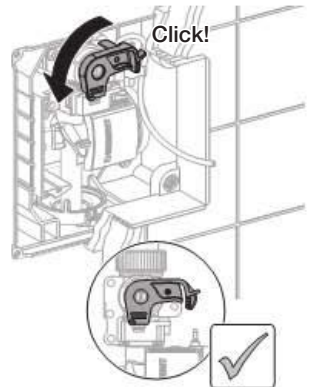

Sumontuoti tvirtinimo rėmą ir darbinę plokštę

1

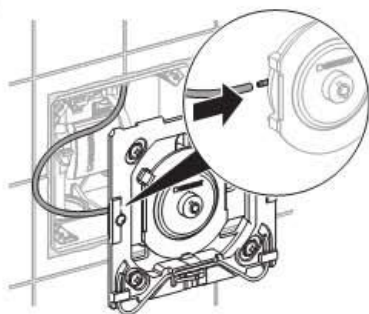

2

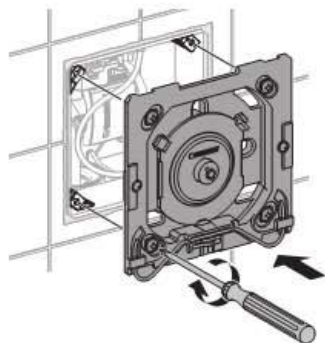

3

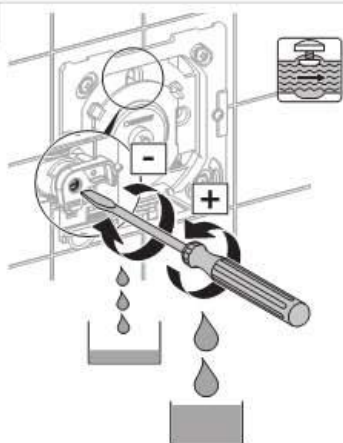

4

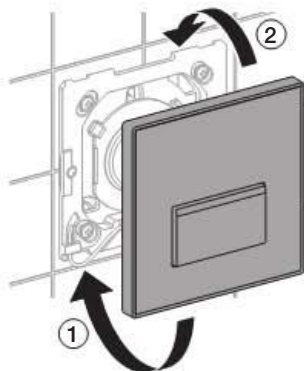

5

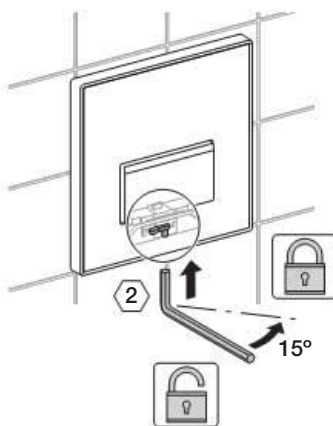

Techniniai duomenys

Pneumatinė „HyTouch“ pusuaro valdymo sistemos dalis

Pralaida esant 1 bar	0,3 / 0,24 (su vandens srauto ribotuviu) l/s
Kontrolinis vandens slėgis	16 bar
Kontrolinis oro slėgis / inertinės dujos	3 bar
Aktyvavimo galia	< 12 N
Vandens tiekimo trukmės nustatymo diapazonas	4 / 8 / 12 s
Oro drėgmė	< 100 %, sant
Slėgio diapazonas eksploatacijos metu	1 - 8 bar
Maksimali darbinė vandens temperatūra	30 °C

Обща информация

Това ръководство за експлоатация Запазете ръководството за експлоатация, така че при необходимост то да може да бъде предоставено на техническия експерт.

Експлоатация, поддръжка Операторът може да извършва само онези дейности по поддръжката, които са предвидени в това ръководство за експлоатация.

Сервиз Сервизни дейности могат да бъдат извършвани само от технически експерт. Некомпетентно извършени дейности могат да доведат до злополуки, материални щети и неправилно функциониране.





Потребителска група

Този документ се отнася до технически експерти съгласно EN IEC 62079:2001.

Употреба

HyTouch автоматите с фотоклетка за писоар са предназначени за промиване на писоари. За наранявания и материални щети, възникнали при използване на уреда не по предназначение, са изключени гаранционни искове и искове за материална отговорност.

Обяснение на символите

Символ	Значение
	ВНИМАНИЕ Означава възможна опасна ситуация, която може да доведе до леко или средно нараняване (телесна повреда) или материални щети.
	Употребете технически вазелин!
	Водата от тръбопровода е спряна
	Водата от тръбопровода е пусната

Контакт

При въпроси или проблеми се свържете с продавача на Geberit във Вашата страна или на адрес www.geberit.com.

Конструкция

Пневматична система на HyTouch автомат за писоар с фотоклетка

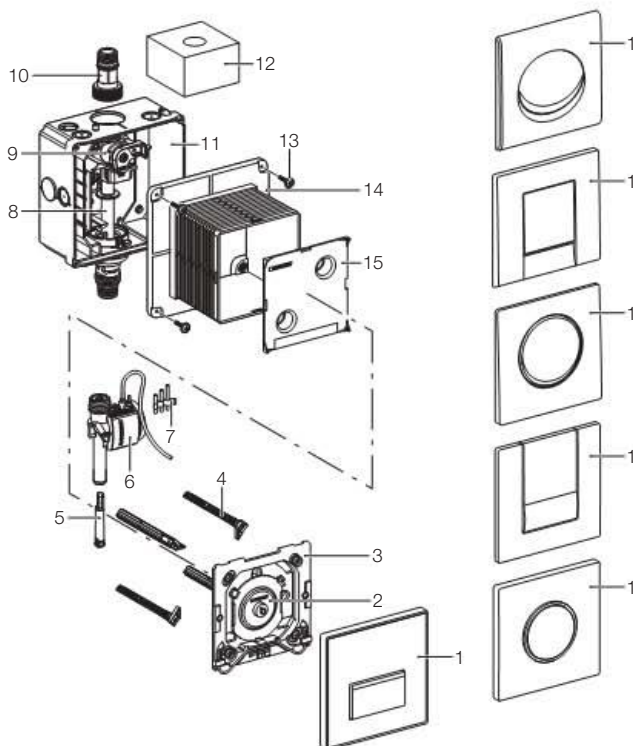

- 1 Командна платка
- 2 Пневматичен бутон
- 3 Монтажна рамка
- 4 Дистанционен болт
- 5 Ограничител на дебита
- 6 Пневматичен вентил
- 7 Комплект дюза
- 8 Водопровод
- 9 Спирателен вентил с клапан
- 10 Свързващ нипел
- 11 Вградена монтажна кутия
- 12 Защитна гъба
- 13 Винтове за захващане
- 14 Защитна кутия
- 15 Защитен капак

Поддръжка

Интервал на поддръжка

Описаните по-долу дейности по поддръжката трябва да се извършват при необходимост, но най-късно на посочените интервали:

- Почистване на повърхността на командната платка - всяка седмица, от оператора
- Почистване на филтъра - на всеки 2 години от технически експерт

Дейности по поддръжката

Почистване на командната платка

ВНИМАНИЕ

! Агресивни и абразивни почистващи препарати могат да увредят покритието.

- ▶ Не използвайте препарати, които са абразивни или разяждащи, съдържат хлор или киселина. Почиствайте само със слаб препарат и вода.



Рекламации за повреди, причинени поради неправилно третиране с почистващи препарати, не могат да бъдат признати.

Почистване или смяна на филтъра



Сервиз

Диагностика на неизправности

Проблем	Възможна причина	Отстраняване
Водата не тече	Захранващият кран е затворен	Отворете захранващия кран
	Филтърът е запушен или замърсен	Почистете или сменете филтъра • Вижте глава "Поддръжка, Почистване и смяна на филтъра"
	Няма налягане във водопроводната мрежа	Проверете налягането на водата • Възстановете налягането на водата
	Куплунгът на пневматичния маркуч между пневматичния бутон и пневматичния вентил е разделен	Създайте връзка на куплунга на пневматичния маркуч
	Пневматичният маркуч е извит или счупен	Сменете дефектния пневматичен маркуч
Смесителят не затвря (водата не спира)	Пневматичният вентил е дефектен	Сменете пневматичния вентил • Вижте "Сервиз, Смяна на пневматичния вентил"
	Клапанът е отворен твърде малко	Отворете клапана
Писоарът не се промива достатъчно	Клапанът е отворен твърде малко	Отворете клапана
От писоара пръска вода за промиване	Твърде висок дебит	Монтирайте ограничител на дебита • Ограничителят на дебита е в продажба като принадлежност (242.484.00.1)

Сервизни дейности

Това ръководство за сервиз показва автомат с вертикален елемент за отвеждане на вода (А). Автоматът с хоризонтален елемент за отвеждане на вода (В) не е показан, сервизните дейности обаче са същите.

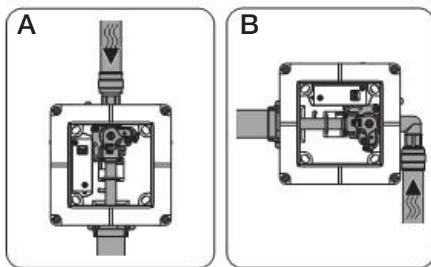

Тук са описани следните сервизни дейности:

- Демонтиране на командната платка и монтажната рамка
- Смяна на пневматичния вентил
- Смяна на регулиращия болт
- Смяна на маншетното уплътнение на тръбопровода
- Монтиране на монтажната рамка и командната платка

Демонтиране на командната платка и монтажната рамка

1

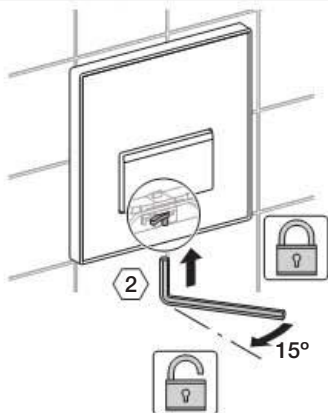

2

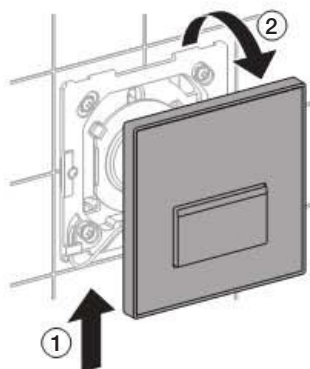

3

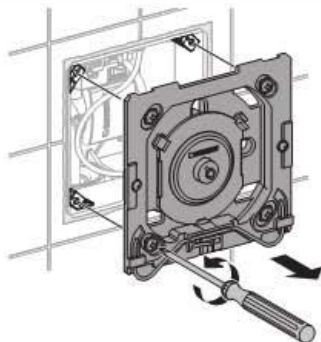

4

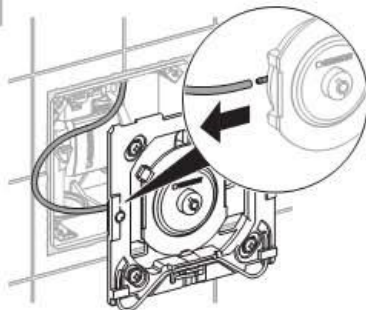

Смяна на пневматичния вентил

Предпоставки

Командната платка и монтажната рамка са демонтирани.

Вижте "Сервиз, демонтиране на командната платка и монтажната рамка".

1

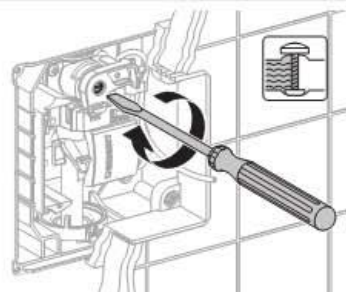

2

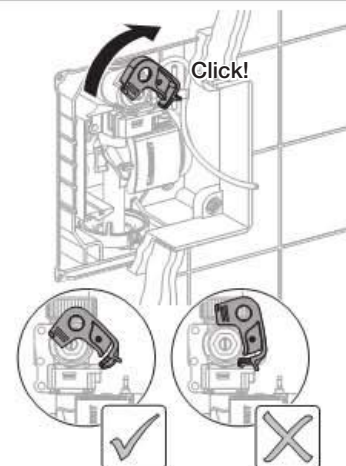

3

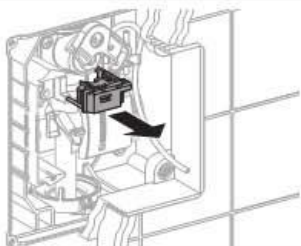

4

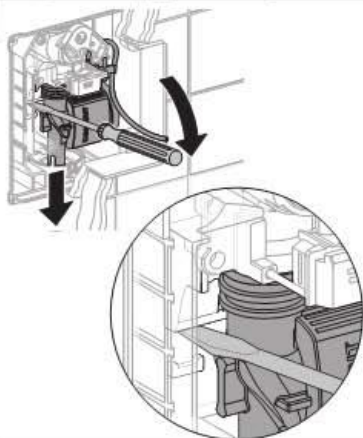

5

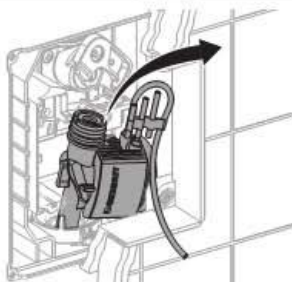

6

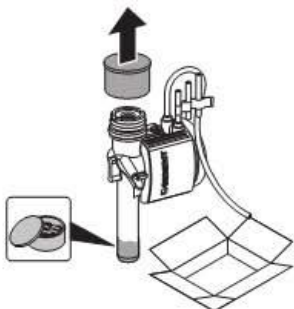

7

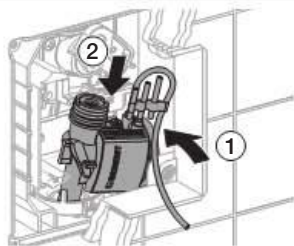

8

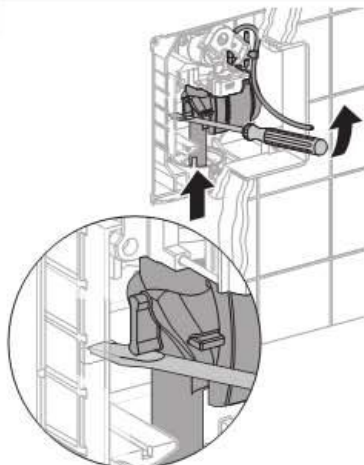

9

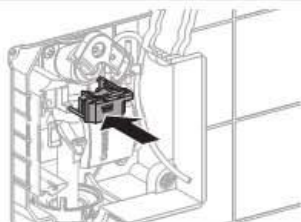

10

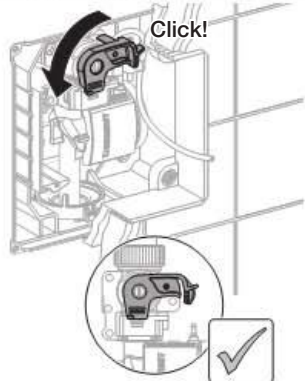

Смяна на регулиращия болт

Предпоставки

Командната платка и монтажната рамка са демонтирани.

Вижте "Сервиз, демонтиране на командната платка и монтажната рамка".

1

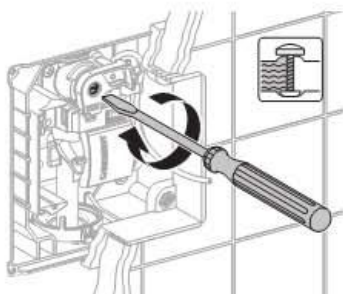

2

Затворете централното кранче.

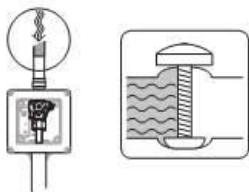

3

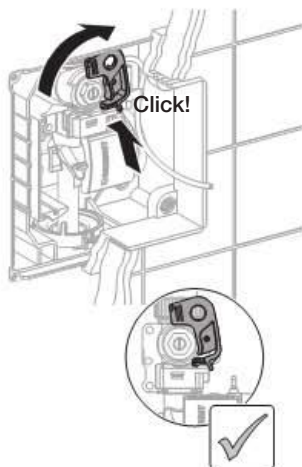

4

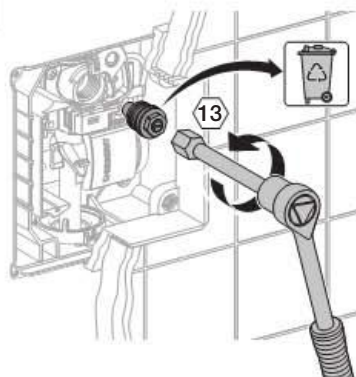

5

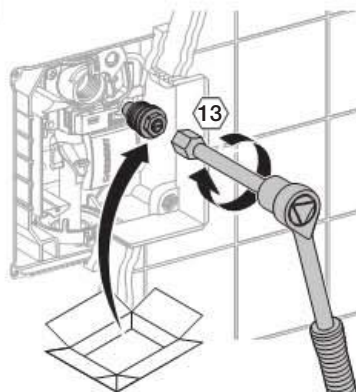

6

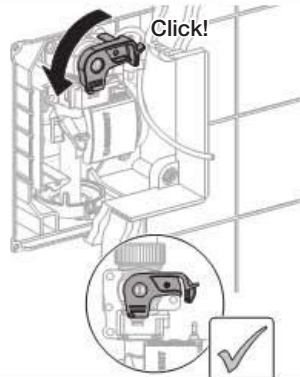

7

Отворете централното кранче.



Смяна на маншетното уплътнение на тръбопровода

Предпоставки

Командната платка и монтажната рамка са демонтирани.

Вижте "Сервиз, демонтиране на командната платка и монтажната рамка".

1

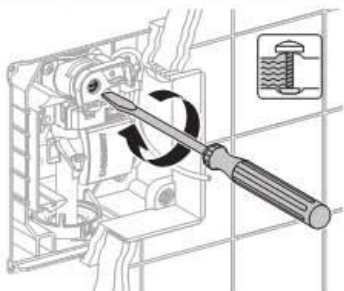

2

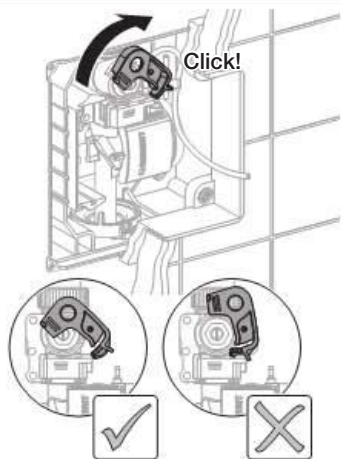

3

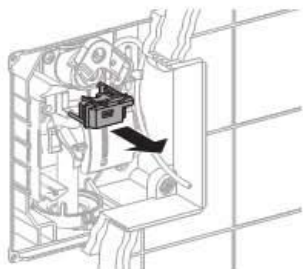

4

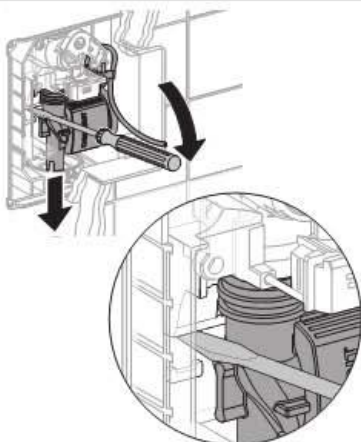

5

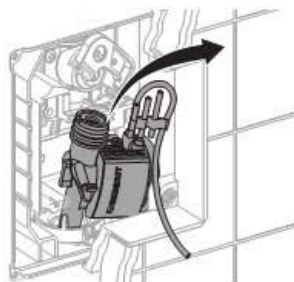

6

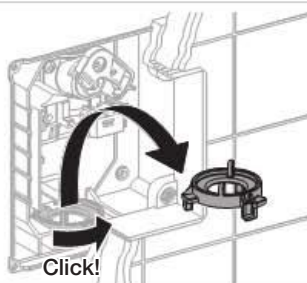

7

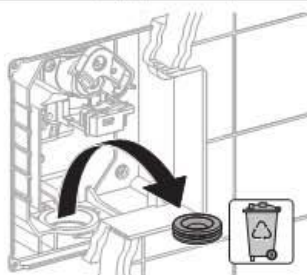

8



9

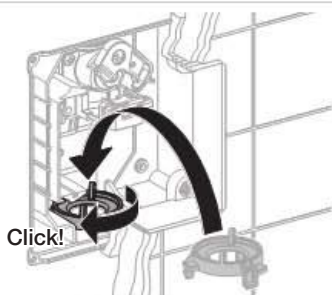

10

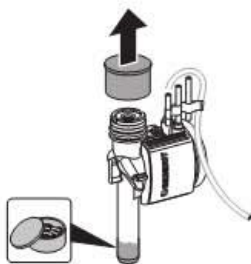

11

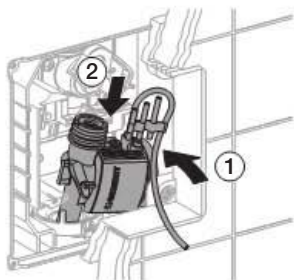

12

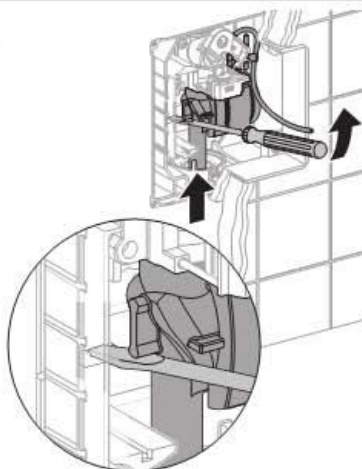

13

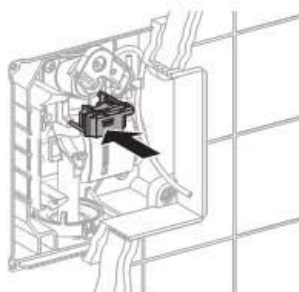

14

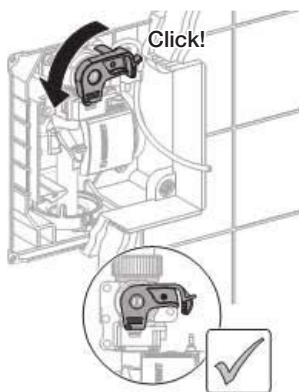

Монтиране на монтажната рамка и командната платка

1

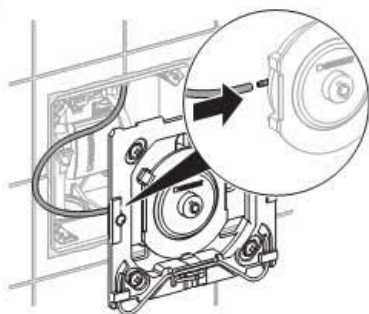

2

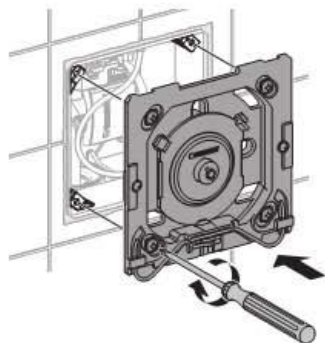

3

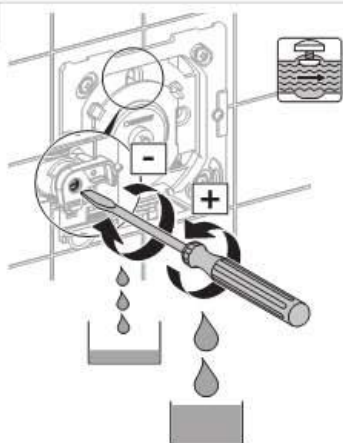

4

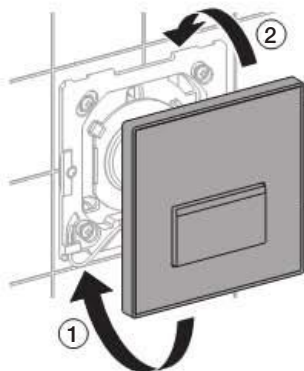

5

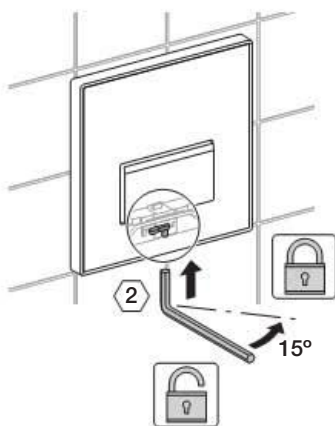

Технически данни

Пневматична система на NuTouch автомат за писоар с фотоклетка

Дебит при 1 bar	0,3 / 0,24 (с ограничител на поток) l/s
Изпитвателно налягане вода	16 bar
Изпитвателно налягане въздух / инертен газ	3 bar
Мощност на управление	< 12 N
Време за промиване обхват на настройване	4 / 8 / 12 s
Влажност на въздуха	< 100 % относително
Диапазон на налягането по време на работа	1 - 8 bar
Максимална работна температура на водата.	30 °C

Informații generale

Aceste indicații pentru operare

Păstrați indicațiile pentru operare, iar în caz de necesitate puneți-le la dispoziție consultantului tehnic de specialitate.

Funcționare, întreținere

Operatorul poate efectua lucrările de întreținere doar conform descrierilor prezentate în aceste instrucțiuni de utilizare.

Service

Lucrările de service pot fi efectuate doar de către un consultant tehnic specializat. Lucrările efectuate incorect pot conduce la provocarea unor accidente, la pagube materiale și disfuncționalități.





Grup țintă

Acest document, conform EN IEC 62079:2001, se adresează consultanților tehnici.

Scopul utilizării

Comenzile de spălare a pisoarului HyTouch sunt destinate clătirii pisoarelor. Dacă s-a utilizat în alt scop decât cel pentru care este prevăzut este exclusă aprobarea reclamațiilor în perioada de garanție sau acordarea altor drepturi de răspundere civilă în momentul apariției unor accidentări a persoanelor sau a unor pagube materiale.

Legendă semne

Simbol	Semnificație
	ATENȚIE Atrage atenția asupra apariției unei posibile situații periculoase, care poate avea drept urmare răniri ușoare sau de gravitate medie sau pagube materiale.
	Utilizați unsoare!
	Apa menajeră din conductă nu curge
	Există apă menajeră în conductă

Contact

În cazul că aveți întrebări sau probleme vă rugăm contactați societatea de desfacere a produselor Geberit competentă sau accesați pagina de internet www.geberit.com.

Structură

Sistemul pneumatic al comenzii pisoarului HyTouch

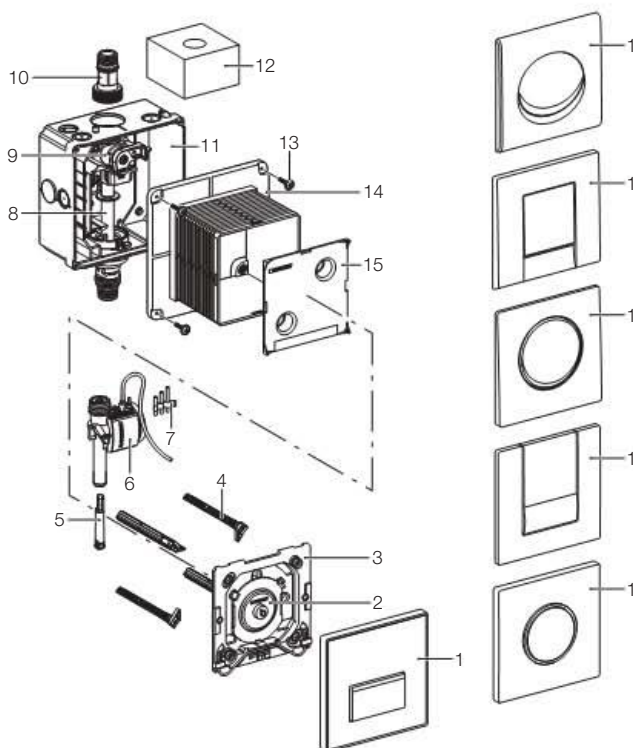

- 1 Clapetă de acționare
- 2 Dispozitiv de acționare pneumatic
- 3 Rama de montare
- 4 Buloane de distanțare
- 5 Limitator de debit
- 6 Valvă electropneumatică
- 7 Set de duze
- 8 Tub de ghidaj
- 9 Robinet de închidere cu supapă de admisie
- 10 Niplu de racordare
- 11 Carcasă-încăstrată
- 12 Burete de protecție
- 13 Șuruburi de fixare
- 14 Casetă de protecție
- 15 Capacul casetei de protecție

Întreținerea

Interval pentru efectuarea lucrărilor de întreținere

Efectuați următoarele lucrări de întreținere în caz de necesitate sau cel târziu la intervalele indicate:

- Curățarea suprafeței clapetei de acționare - săptămânal de către operator
- Curățarea filtrului coș pentru impurități - tot la 2 ani, de către un consultant tehnic

Lucrări de întreținere

Curățarea clapetei de acționare



ATENȚIE

Detergenții și prafurile de curățat agresive pot deteriora suprafața.

- ▶ A nu se utiliza detergenți care conțin clor sau acizi, substanțe abrazive sau corozive, ci doar detergenți moi în amestec cu apă



Nu pot fi recunoscute reclamațiile referitoare la defecte, apărute în urma unor tratări incorecte cu detergenți necorespunzători.

Curățați sau schimbați filtrul coș pentru impurități



Service

Remedierea defecțiunilor tehnice

Problema	Cauză posibilă	Remediere
Apa nu curge	Valva de alimentare cu apă este închisă	Deschideți valva de alimentare cu apă
	Filtrul coș pentru impurități este blocat sau prezintă impurități	Curățați sau schimbați filtrul coș pentru impurități • Vezi capitolul "Întreținere, curățarea sau înlocuirea filtrului coș pentru impurități"
	Nu există presiune în rețeaua de apă	Verificați presiunea apei • Refaceți presiunea apei
	Priza de legătură a furtunului pneumatic dintre dispozitivul de acționare pneumatic și valva electropneumatică nu este conectată	Realizați priza de legătură a furtunului pneumatic
	Furtunul pneumatic este îndoit sau rupt	Înlocuiți furtunul pneumatic defect
	Valva electropneumatică este defectă	Înlocuiți valva electropneumatică • Vezi capitolul "Service, Schimbarea valvei electropneumatice"
Curgere continuă (Nu se mai oprește curgerea apei)	Valva electropneumatică este defectă	Înlocuiți valva electropneumatică • Vezi capitolul "Service, Schimbarea valvei electropneumatice"
Pisoarul nu este spălat suficient	Supapa de admisie nu este deschisă suficient	Deschideți supapa de admisie
Apa pentru spălare stropște din pisoar	Debit de curgere prea mare	Montați limitatorul de debit • Limitatorul de debit îl puteți achiziționa ca accesoriu (242.484.00.1)

Lucrări de service

În aceste instrucțiuni de service este prezentată comanda cu tub vertical de ghidaj al apei (A). Comanda cu tub orizontal de ghidaj al apei (B) nu este prezentată, însă lucrările de service sunt aceleași.

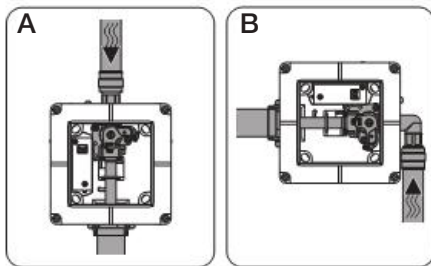

Aici sunt descrise următoarele lucrări de service:

- Demontați clapeta de acționare și rama de montare
- Înlocuiți valva electropneumatică
- Schimbați șurubul de reglare
- Schimbați inelul de etanșare a conductei de spălare
- Montați rama de montare și clapeta de acționare

Demontați clapeta de acționare și rama de montare

1

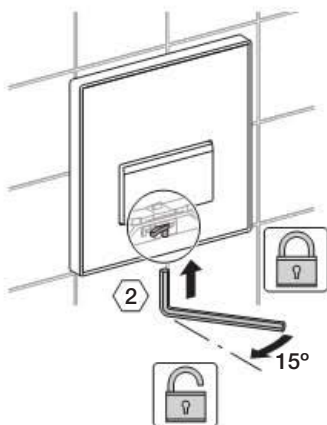

2

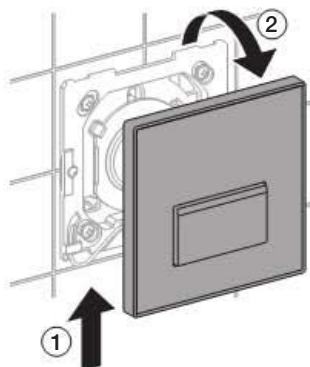

3

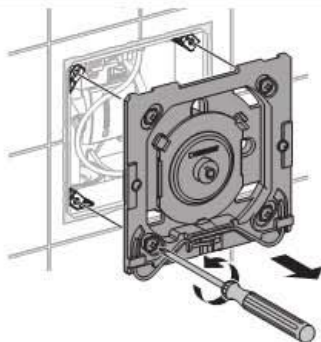

4

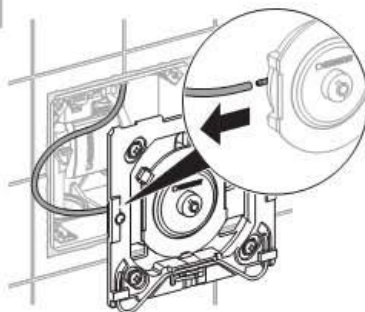

Înlocuiți valva electropneumatică

Premisă

Clapeta de acționare și rama de montare sunt demontate.

Vezi "Service, demontarea clapetei de acționare și a ramei de montare".

1

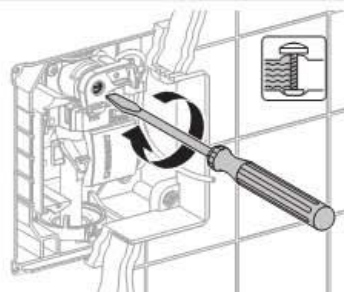

2

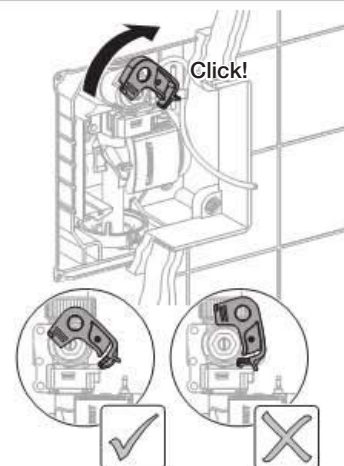

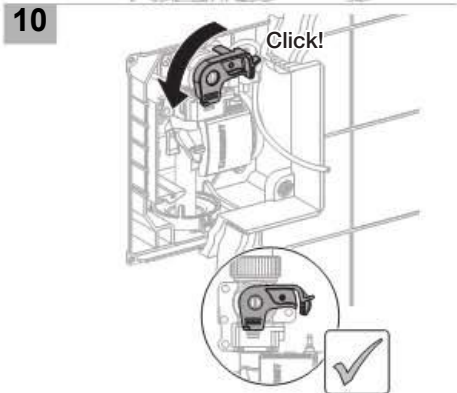
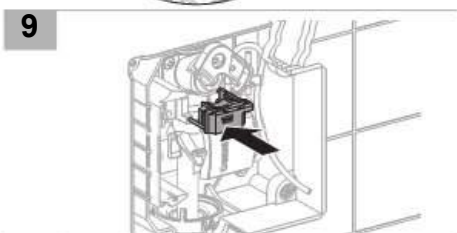
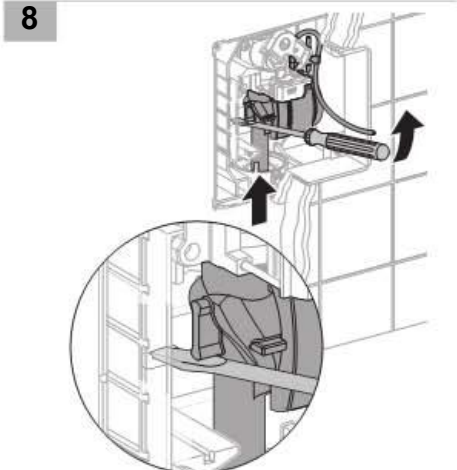
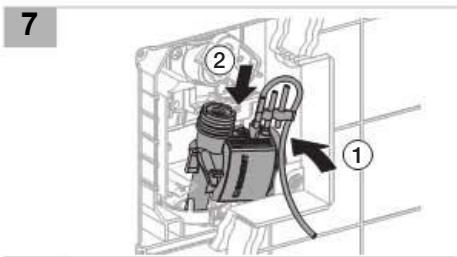
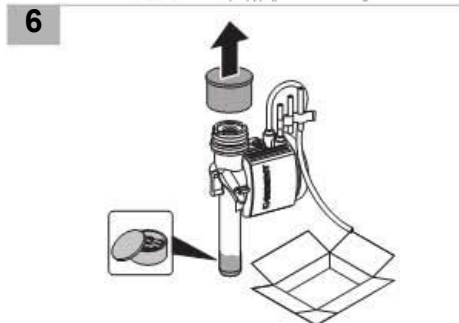
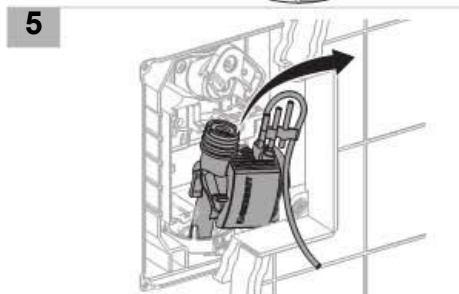
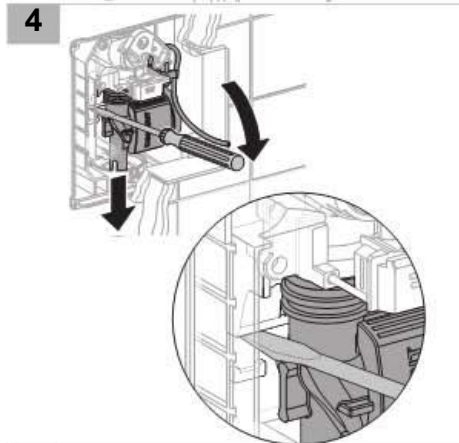
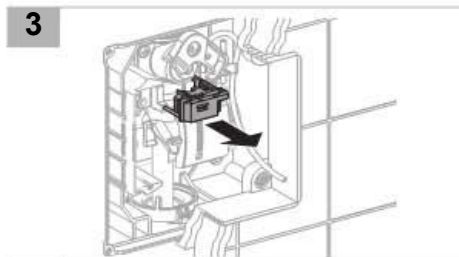

Schimbați șurubul de reglare

Premisă

Clapeta de acționare și rama de montare sunt demontate.

Vezi "Service, demontarea clapetei de acționare și a ramei de montare".

1

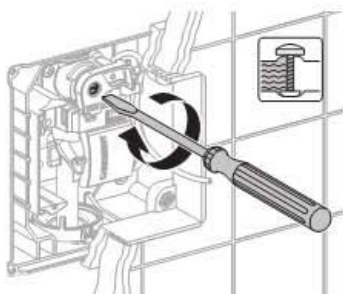

2 Închideți valva centrală de alimentare cu apă.

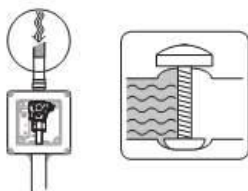

3

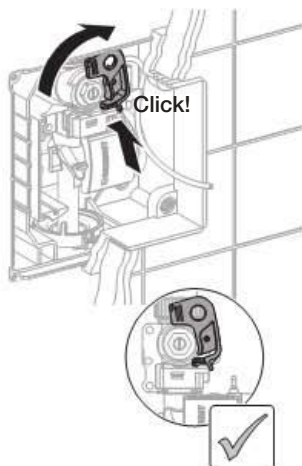

4

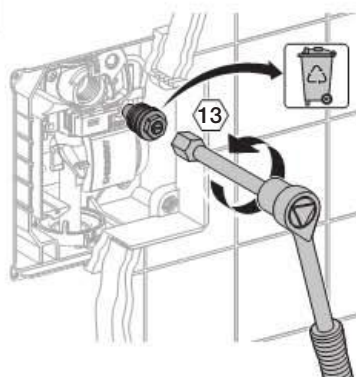

5

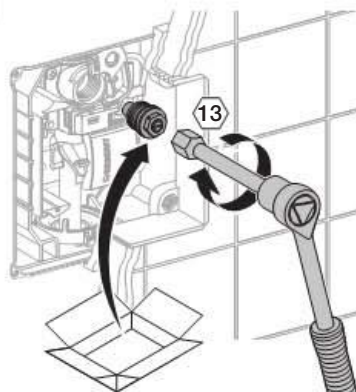

6

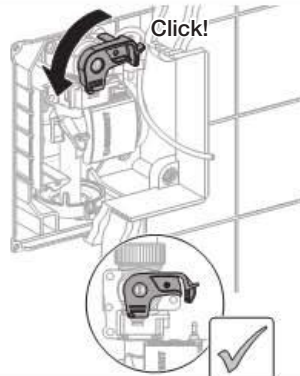

7 Deschideți valva centrală de alimentare cu apă.



Schimbați inelul de etanșare a conductei de spălare

Premisă

Clapeta de acționare și rama de montare sunt demontate.

Vezi "Service, demontarea clapetei de acționare și a ramei de montare".

1

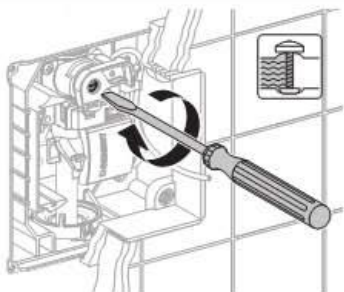

2

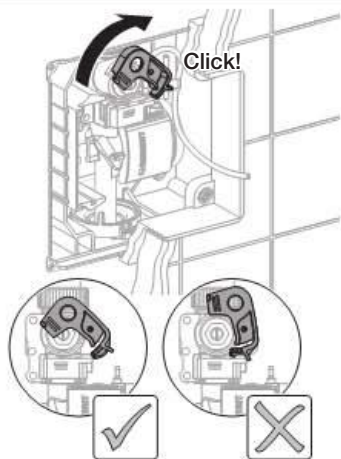

3

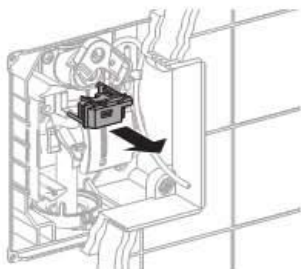

4

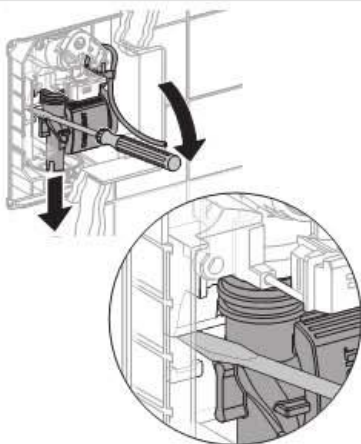

5

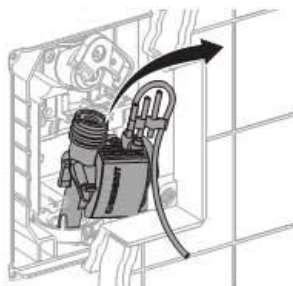

6

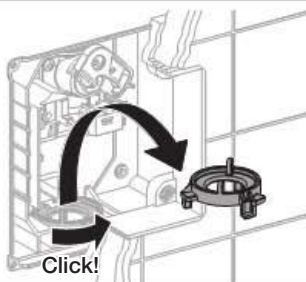

7

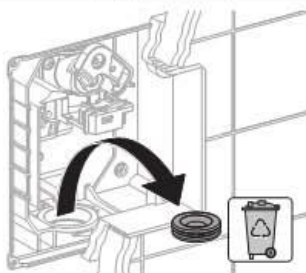

8



9

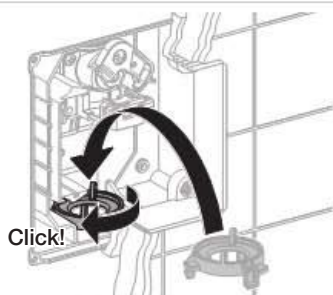

10

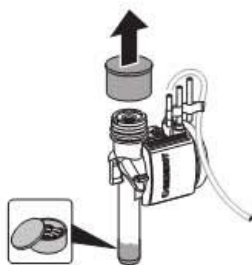

11

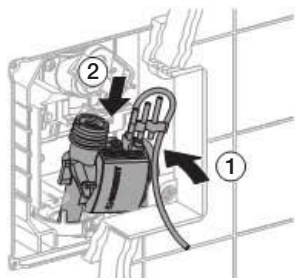

12

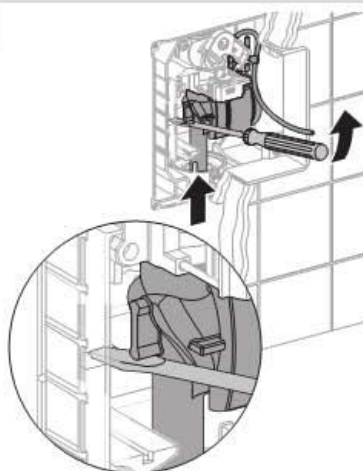

13

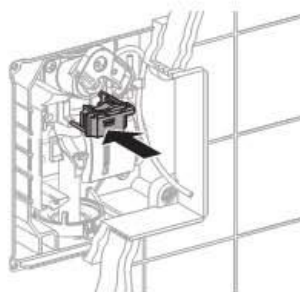

14

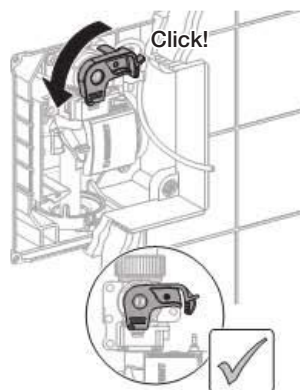

Montați rama de montare și clapeta de acționare

1

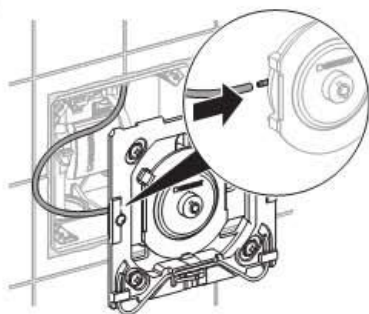

2

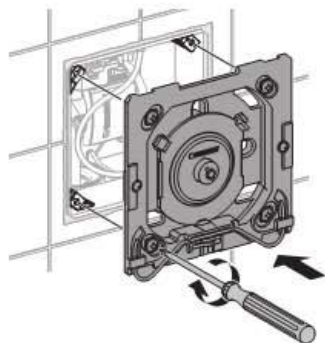

3

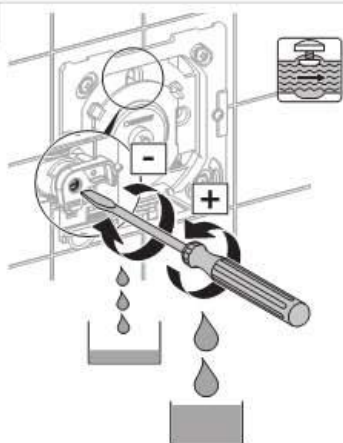

4

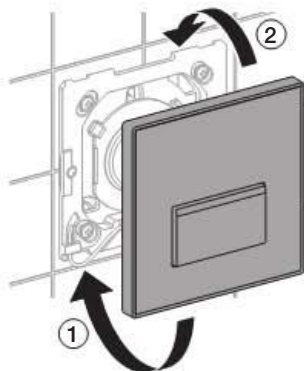

5

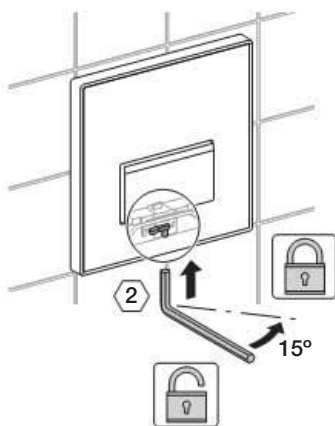

Date tehnice

Sistemul pneumatic al comenzii pisoarului HyTouch

Debit de curgere la 1 bar	0,3 / 0,24 (cu limitator de debit) l/s
Presiune de încercare apă	16 bar
Presiune de încercare aer / gaz inert	3 bar
Forța de acționare	< 12 N
Timp de spălare intervalul de reglare	4 / 8 / 12 s
Umiditatea aerului	< 100 % relativă
Intervalul de presiune în timpul exploatării	1 - 8 bari
Temperatura de funcționare max. a apei	30 °C

Γενικές υποδείξεις

Το παρόν εγχειρίδιο λειτουργίας

Φυλάξτε το εγχειρίδιο λειτουργίας και, αν χρειαστεί, προσκομίστε το σε κάποιο εξειδικευμένο άτομο.

Λειτουργία, συντήρηση

Οι εργασίες συντήρησης επιτρέπεται να εκτελούνται από τον χειριστή μόνο στο βαθμό που περιγράφεται σε αυτές τις οδηγίες.

Σέρβις

Οι εργασίες σέρβις επιτρέπεται να εκτελούνται μόνο από εξειδικευμένο άτομο. Οι ακατάλληλες εργασίες ενδέχεται να οδηγήσουν σε ατυχήματα, υλικές ζημιές και διαταραχές λειτουργίας.





Που απευθύνονται

Το έγγραφο αυτό απευθύνεται σε ειδικευμένους τεχνικούς σύμφωνα με το EN IEC 62079:2001.

Ενδεδειγμένη χρήση

Οι έλεγχοι απόπλυσης ουρητηρίων HyTouch προορίζονται για την πλύση των ουρητηρίων. Σε περίπτωση μη ενδεδειγμένης χρήσης, αποκλείεται κάθε αξίωση παροχής εγγύησης και ευθύνη σε περίπτωση τραυματισμών και υλικών ζημιών.

Επεξήγηση συμβόλων

Σύμβολο	ΠΡΟΣΟΧΗ	Σημασία
		Επισημαίνει μια ενδεχομένως επικίνδυνη κατάσταση που μπορεί να επιφέρει ελαφρό ή μέσο σωματικό τραυματισμό ή υλικές ζημιές.
		Χρησιμοποιείτε λιπαντικό γράσο!
		Διακοπή νερού βρύσης
		Σύνδεση νερού βρύσης

Επικοινωνία

Σε περίπτωση αποριών ή προβλημάτων επικοινωνήστε με την αρμόδια εταιρεία διάθεσης-πώλησης της Geberit ή επισκεφθείτε τη διεύθυνση www.geberit.com.

Δομή

Πνευματικός έλεγχος απόπλυσης ουρητηρίου HyTouch

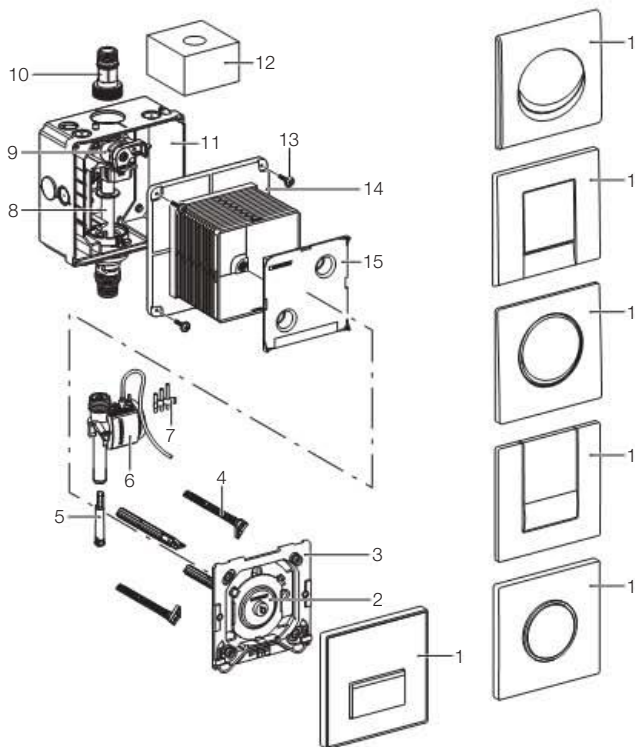

- 1 Πλακίδιο ενεργοποίησης
- 2 Πνευματικό κουμπί
- 3 Πλαίσιο στήριξης
- 4 Πείρος στερέωσης πλαισίου
- 5 Περιοριστής ροής
- 6 Βαλβίδα πνευματικού συστήματος
- 7 Σετ ακροφυσίων
- 8 Σπирάλ περιβλημα καλωδίων
- 9 Βαλβίδα διακοπής με ρυθμιστή
- 10 Εξάρτημα σύνδεσης
- 11 Κουτί εντοιχισμού
- 12 Προστατευτικό σφουγγαράκι
- 13 Βίδες
- 14 Κυτίο προστασίας
- 15 Κάλυμμα κυτίου προστασίας

Συντήρηση

Περίοδος συντήρησης

Οι παρακάτω εργασίες συντήρησης πρέπει να εκτελούνται όποτε απαιτείται, ωστόσο το αργότερο στα καθορισμένα χρονικά διαστήματα:

- Καθαρισμός επιφάνειας του πλακιδίου ενεργοποίησης - κάθε εβδομάδα, από τον χειριστή
- Καθαρισμός του φίλτρου - κάθε 2 χρόνια, από ειδικευμένο τεχνικό

Εργασίες συντήρησης

Καθαρισμός του πλακιδίου ενεργοποίησης

ΠΡΟΣΟΧΗ

Τα διαβρωτικά μέσα καθαρισμού και τα μέσα καθαρισμού με τριβή μπορούν να βλάψουν την επιφάνεια.

- ▶ Μην χρησιμοποιείτε μέσα καθαρισμού χλωριούχα, όξινα, τριβής ή καυστικά, παρά μόνο ήπια μέσα καθαρισμού και νερό

Απαιτήσεις εγγύησης που προέρχονται από ακατάλληλη χρήση μέσων καθαρισμού δεν λαμβάνονται υπόψη.

Καθαρίστε ή αντικαταστήστε το φίλτρο



Σέρβις

Προβλήματα-Λύσεις

Πρόβλημα	Πιθανή αιτία	Λύση
Δεν τρέχει καθόλου νερό	<p>Η βαλβίδα παροχής νερού είναι κλειστή</p> <p>Το φίλτρο είναι μπλοκαρισμένο ή λερωμένο</p>	<p>Ανοίξτε την βαλβίδα παροχής νερού</p> <p>Καθαρίστε ή αντικαταστήστε το φίλτρο</p> <ul style="list-style-type: none"> • Βλ. "Συντήρηση, καθαρισμός ή αντικατάσταση του φίλτρου"
	<p>Δεν υπάρχει πίεση στο δίκτυο ύδρευσης</p>	<p>Ελέγξτε την πίεση του νερού</p> <ul style="list-style-type: none"> • Αποκαταστήστε την πίεση του νερού
	<p>Η κουμπωτή σύνδεση του εύκαμπτου σωλήνα πνευματικού συστήματος μεταξύ κομβίου πνευματικού συστήματος και βαλβίδας πνευματικού συστήματος έχει ανοίξει</p>	<p>Αποκαταστήστε την κουμπωτή σύνδεση του εύκαμπτου σωλήνα πνευματικού συστήματος</p>
	<p>Ο εύκαμπτος σωλήνας πνευματικού συστήματος είναι στρεβλωμένος ή σπασμένος</p>	<p>Αντικαταστήστε τον ελαττωματικό εύκαμπτο σωλήνα πνευματικού συστήματος</p>
	<p>Η βαλβίδα πνευματικού συστήματος είναι ελαττωματική</p>	<p>Αντικαταστήστε τη βαλβίδα πνευματικού συστήματος</p> <ul style="list-style-type: none"> • Βλέπε "Επισκευή, αντικατάσταση βαλβίδας πνευματικού συστήματος"
Συνεχής ροή (το νερό δεν σταματάει)	<p>Η βαλβίδα πνευματικού συστήματος είναι ελαττωματική</p>	<p>Αντικαταστήστε τη βαλβίδα πνευματικού συστήματος</p> <ul style="list-style-type: none"> • Βλέπε "Επισκευή, αντικατάσταση βαλβίδας πνευματικού συστήματος"
Ανεπαρκής απόπλυση ουρητήρα	<p>Ο ρυθμιστής είναι ελάχιστα ανοιχτός</p>	<p>Ανοίξτε το ρυθμιστή</p>
Νερό έκπλυσης πετάγεται έξω από τον ουρητήρα	<p>Πολύ μεγάλος όγκος ροής</p>	<p>Συναρμολογήστε έναν περιοριστή όγκου ροής</p> <ul style="list-style-type: none"> • Ο περιοριστής όγκου ροής διατίθεται ως προαιρετικός εξοπλισμός (242.484.00.1)

Εργασίες επισκευής

Αυτό το εγχειρίδιο επισκευής δείχνει το σύστημα ελέγχου με κάθετη ροή νερού (Α). Δεν παρουσιάζεται το σύστημα ελέγχου με οριζόντια ροή νερού (Β), οι εργασίες επισκευής όμως είναι ίδιες.

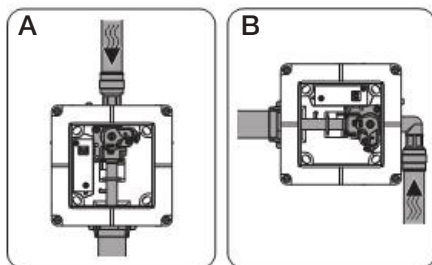

Εδώ περιγράφονται οι παρακάτω εργασίες επισκευής:

- Αποσυναρμολογήστε το πλακίδιο ενεργοποίησης και το πλαίσιο στήριξης
- Αντικαταστήστε τη βαλβίδα πνευματικού συστήματος
- Αντικαταστήστε τη βίδα ρύθμισης
- Αντικαταστήστε τη φλάντζα χείλους του αγωγού πλύσης
- Συναρμολογήστε το πλαίσιο στήριξης και το πλακίδιο ενεργοποίησης

Αποσυναρμολογήστε το πλακίδιο ενεργοποίησης και το πλαίσιο στερέωσης

1

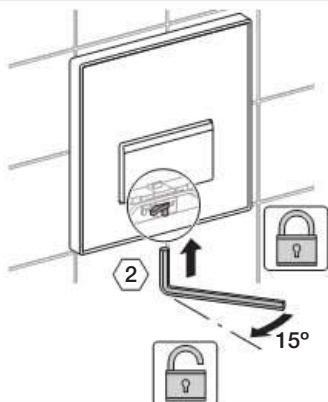

2

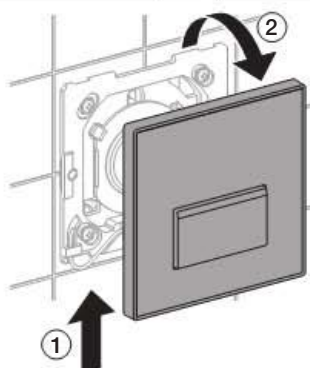

3

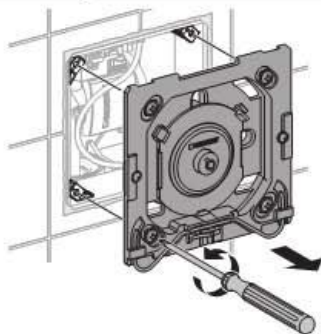

4

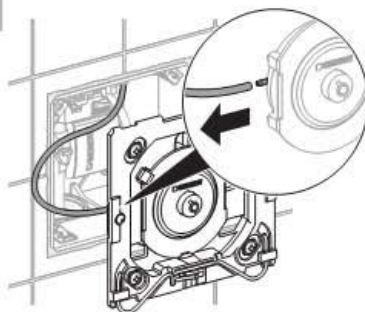

Αντικαταστήστε τη βαλβίδα πνευματικού συστήματος

ΠΡΟΫΠΟΘΕΣΕΙΣ

Το πλακίδιο ενεργοποίησης και το πλαίσιο στήριξης έχουν αποσυναρμολογηθεί.

Βλέπε "Επισκευή, αποσυναρμολόγηση πλακιδίου ενεργοποίησης και πλαισίου στήριξης".

1

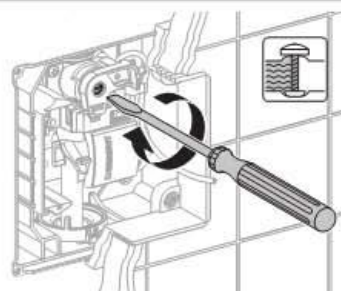

2

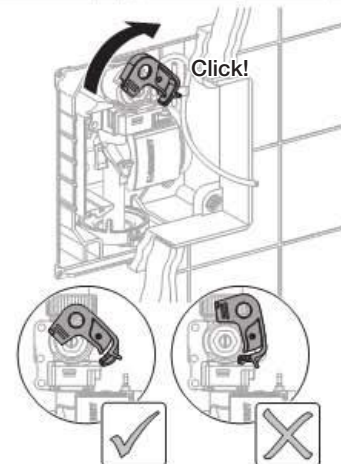

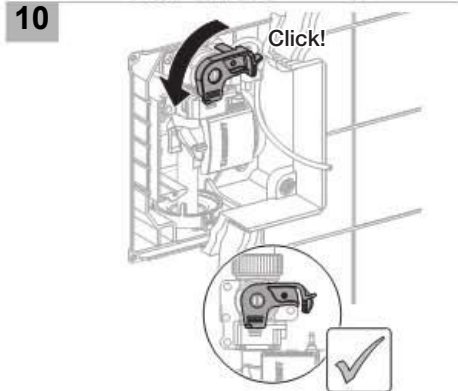
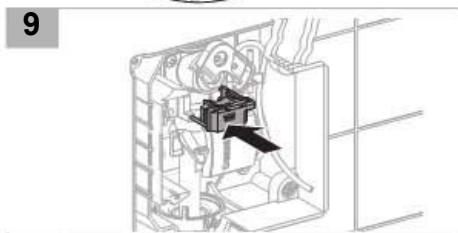
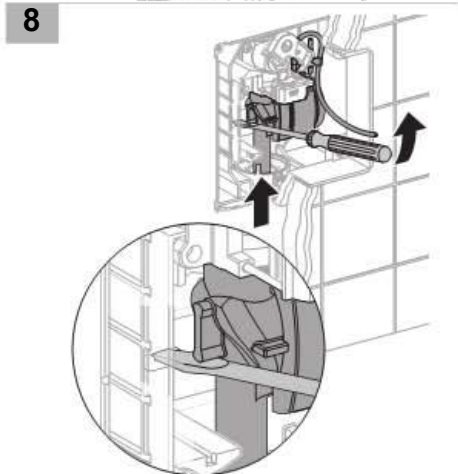
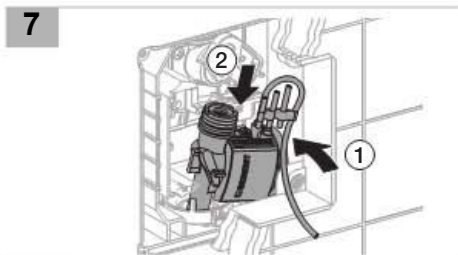
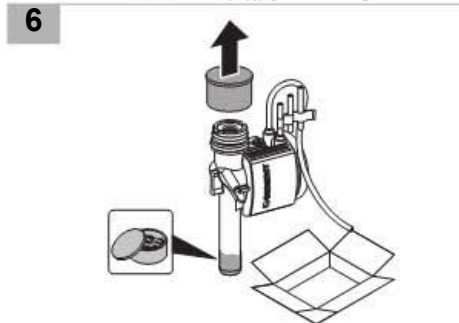
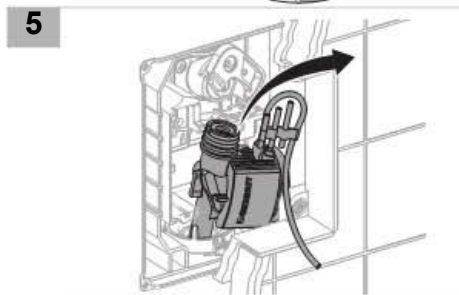
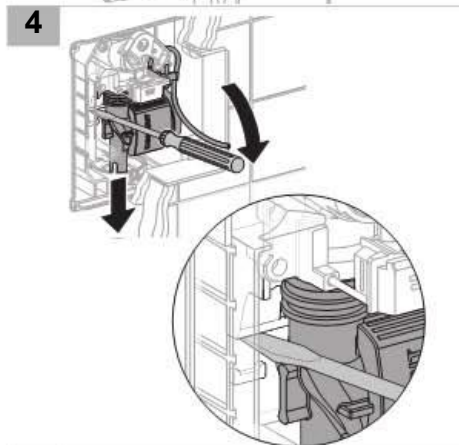
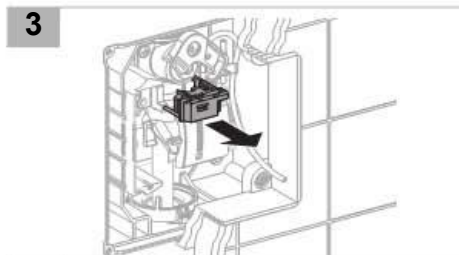

Αντικαταστήστε τη βίδα ρύθμισης**ΠΡΟΫΠΟΘΕΣΕΙΣ**

Το πλακίδιο ενεργοποίησης και το πλαίσιο στήριξης έχουν αποσυναρμολογηθεί.

Βλέπε "Έπισκευή, αποσυναρμολόγηση πλακιδίου ενεργοποίησης και πλαισίου στήριξης".

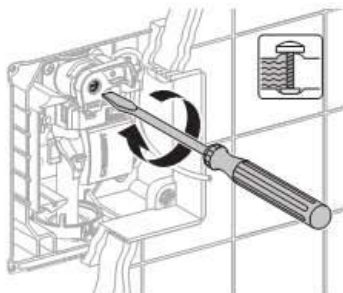
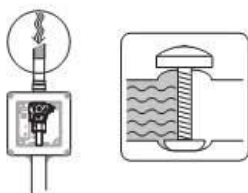
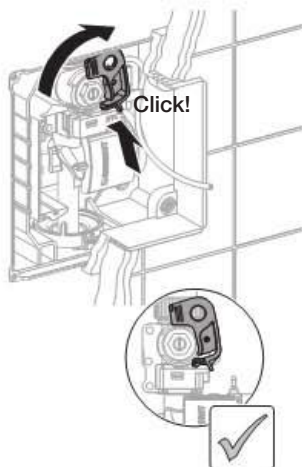
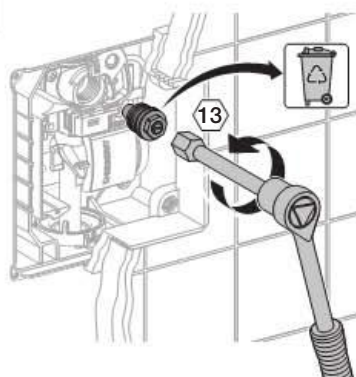
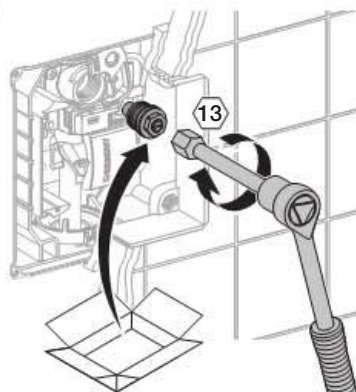
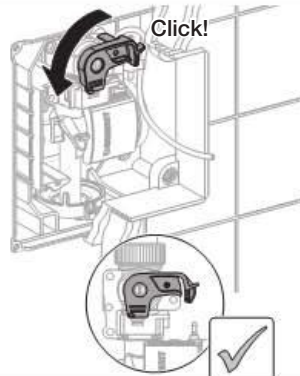
1**2** Κλείστε την κεντρική βαλβίδα παροχής νερού.**3****4****5****6****7** Ανοίξτε την κεντρική βαλβίδα παροχής νερού.

Αντικαταστήστε τη φλάντζα χείλους του αγωγού πλύσης

ΠΡΟΫΠΟΘΕΣΕΙΣ

Το πλακίδιο ενεργοποίησης και το πλαίσιο στήριξης έχουν αποσυναρμολογηθεί. Βλέπε "Επισκευή, αποσυναρμολόγηση πλακιδίου ενεργοποίησης και πλαισίου στήριξης".

1

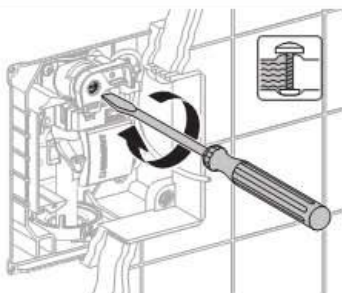

2

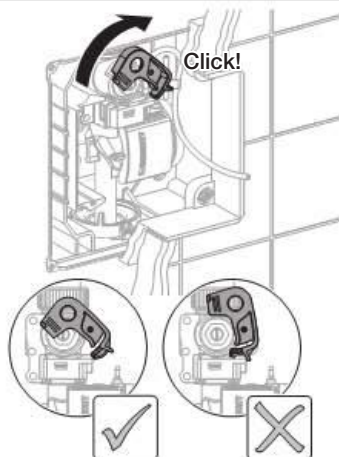

3

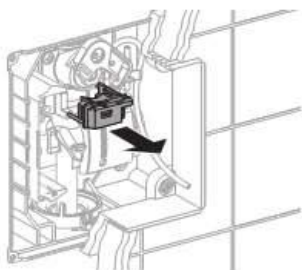

4

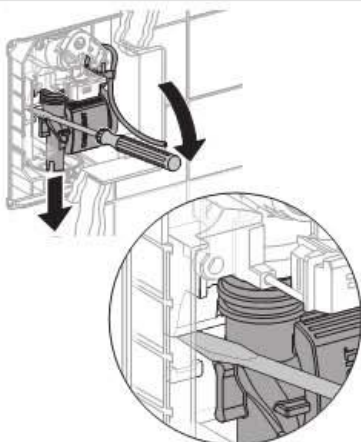

5

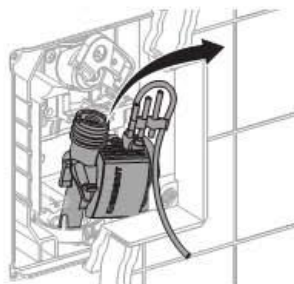

6

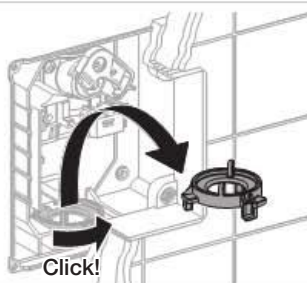

7

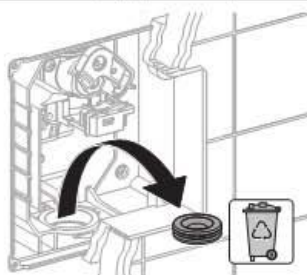

8



9



10

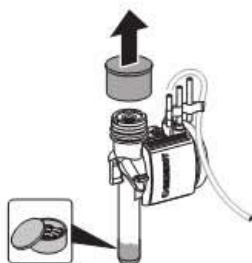

11

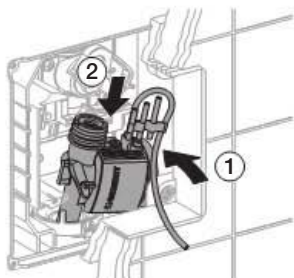

12

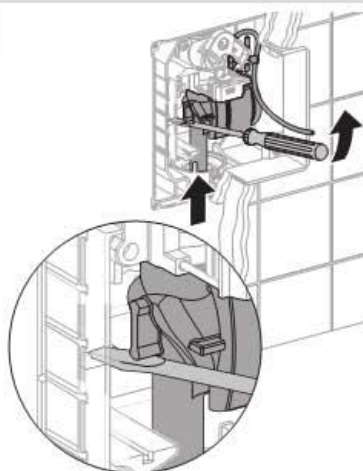

13

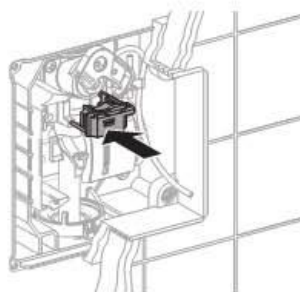

14

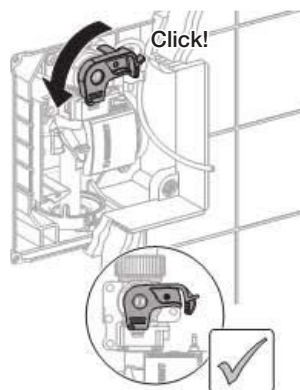

Συναρμολογήστε το πλαίσιο στήριξης και το πλακίδιο ενεργοποίησης

1

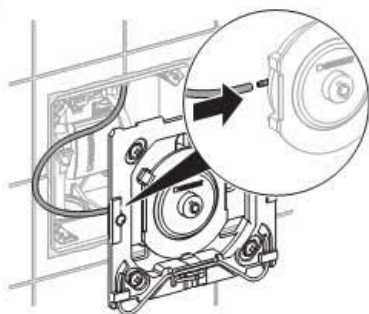

2

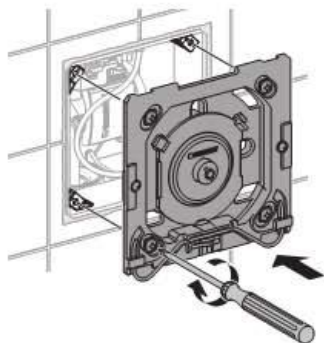

3

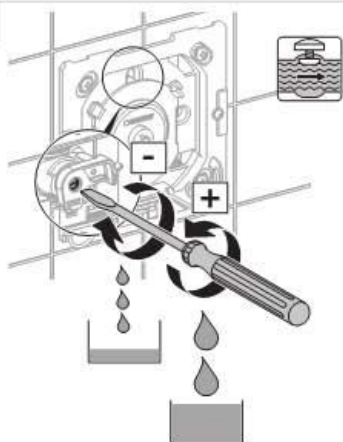

4

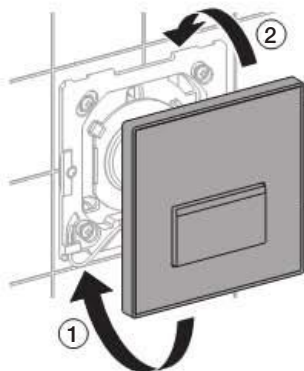

5

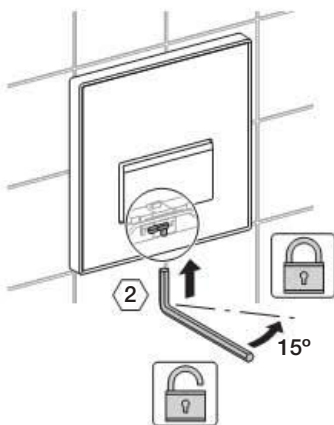

Τεχνικά στοιχεία

Πνευματικός έλεγχος απόπλυσης ουρητηρίου HyTouch

Όγκος ροής στο 1 bar	0,3 / 0,24 (με περιοριστή όγκου ροής) l/s
Πίεση ελέγχου νερού	16 bar
Πίεση ελέγχου αέρα / αδρανούς αερίου	3 bar
Δύναμη ενεργοποίησης	< 12 N
Περιοχή ρύθμισης χρόνου πλύσης	4 / 8 / 12 s
Υγρασία	< 100 % σχετική
Διαφορά πίεσης κατά την λειτουργία	1 - 8 bar
Μέγ. θερμοκρασία λειτουργίας νερού	30 °C

Genel bilgiler





Bu işletme kılavuzu	İşletme kılavuzunu saklayın ve gereğinde uzman personelin kullanımına sunun.
İşletme, bakım	Bakım işleri, operatör taraf ndan yalnızca bu kılavuzda tanımlandığı kadarıyla gerçekleştirilebilir.
Servis	Servis işleri yalnızca bir uzman tarafından yapılmalıdır. Hatalı çalışmalar kazalara, maddi hasarlara ve işletme sırasında sorunlara neden olabilir.
Hedef grup	

Bu doküman, EN IEC 62079:2001 uyarınca uzmanlar için hazırlanmıştır.

Amacına uygun kullanım

HyTouch pisuvar deşarj kontrolleri, pisuvarların yıkanması için öngörülmüştür. Amacına uygun olmayan kullanım durumunda insana ve mala gelecek zararlara karşı garanti verilmez ve sorumluluk üstlenilmez.

Simgelerin açıklaması

Simge	Anlamı
	DİKKAT Hafif veya orta ağırlıkta yaralanmalara veya maddi hasara neden olabilecek muhtemelen tehlikeli durumlara dikkat çeker.
	Gres kullanın!
	Musluk suyu kesik
	Musluk suyu aç k

İletişim

Sorularınız ve sorunlarınız olduğunda, yetkili Geberit dağıtım şirketinize veya www.geberit.com adresine başvurun.

Yapısı

HyTouch pnömatik pisuvar deşarj kontrolü

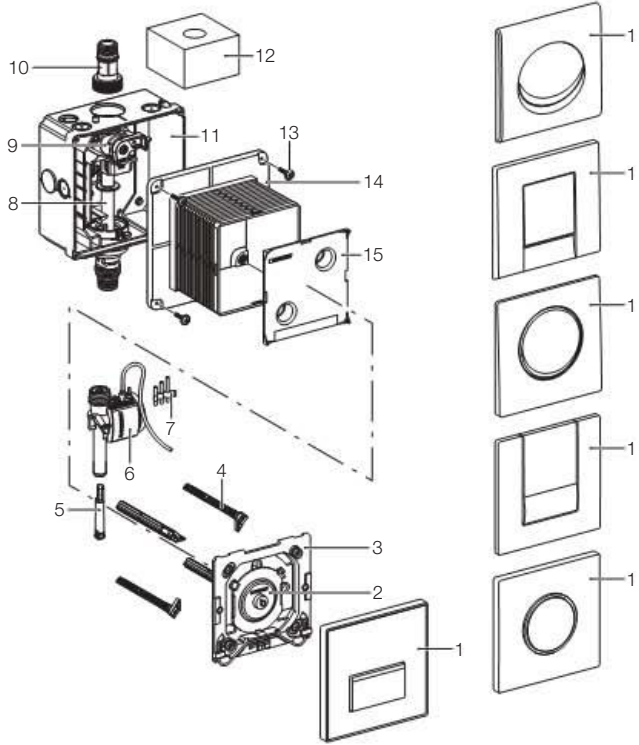

- 1 Kumanda kapağı
- 2 Pnömatik buton
- 3 Montaj çerçevesi
- 4 Mesafe pimi
- 5 Akış hızı sınırlayıcı
- 6 Pnömatik valf
- 7 Meme seti
- 8 Boş boru
- 9 Valflı giriş vanası
- 10 Bağlantı nipel
- 11 Ankastr gövde
- 12 Koruyucu sünger
- 13 Bağlantı vidaları
- 14 Şablon kutusu
- 15 Şablon kutusu kapağı

Bakım

Bakım aralığı

Aşağıdaki bakım işleri gereğinde, ama en geç belirtilen aralıklarla yapılır:

- Kumanda kapağının yüzeyinin temizlenmesi – haftada bir kez operatör tarafından
- Filtre sepetinin temizlenmesi – 2 yılda bir uzman tarafından yapılmalıdır

Bakım işleri

Basma plakasının temizlenmesi



DİKKAT

Agresif ve aşındırıcı temizlik deterjanları yüzeyde tahribata neden olabilir.

- ▶ Klor veya asit içeren, aşındırıcı veya tahriş edici temizlik malzemeleri yerine sadece su ve yumuşak temizlik malzemelerini kullanınız.



Hatalı deterjan kullanılarak yapılan temizlik işlemlerinin neden olduğu şikayetler kabul edilmeyecektir.

Filtre sepetinin temizlenmesi veya değiştirilmesi



Servis

Hata arama

Sorun	Muhtemel neden	Yardım
Su akıyor	Ana su vanası kapalı	Ana su vanası açılmalı
	Filtre sepeti tıkalı veya kirlı	Filtre sepeti temizlenmeli veya değiştirilmeli • Bkz. "Periyodik bakım, filtre sepetinin temizlenmesi veya değiştirilmesi"
	Su şebekesinde basınç yok	Su basıncı kontrol edilmeli • Su basıncının gelmesini sağlayın
	Pnömatik buton ile pnömatik valf arasındaki pnömatik hortum tapa bağlantısı kopmuş	Pnömatik hortum tapa bağlantısı oluşturulmalı
	Pnömatik hortumu bükülmüş veya kırılmış	Hatalı pnömatik hortum değiştirilmeli
Devamlı akış (su akışı durmuyor)	Pnömatik valf hatalı	Pnömatik valf değiştirilmeli • Bkz. "Servis, Pnömatik valfın değiştirilmesi"
	Valf yeterince açık değil	Valf açılmalı
Pisuvardan yıkama suyu sızıyor	Çok yüksek akış	Akış sınırlayıcısı takılmalı • Akış sınırlayıcısı aksesuar olarak mevcuttur (242.484.00.1)

Servis işleri

Bu servis kılavuzu dikey su akışlı kumanda sistemini (A) göstermektedir. Yatay su akışlı kumanda sistemi (B) burada gösterilmemektedir, ama servis işleri aynıdır.

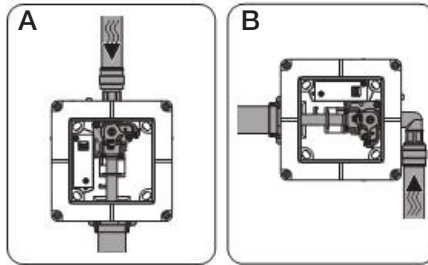

Burada, şu servis işleri tanımlanmaktadır:

- Kumanda kapağının ve montaj çerçevesinin sökülmesi
- Pnömatik valfın değiştirilmesi
- Ayar vidasının değiştirilmesi
- Yıkama hattındaki dudaklı contanın değiştirilmesi
- Montaj çerçevesinin ve kumanda kapağının monte edilmesi

Basma plakasının ve montaj çerçevesinin sökülmesi

1

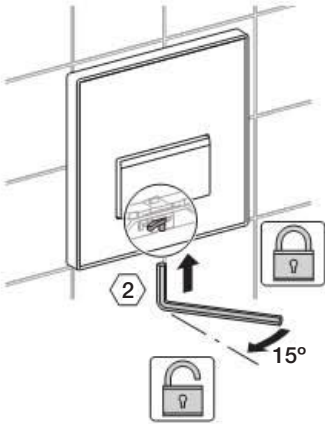

2

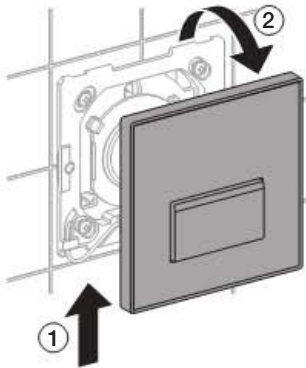

3

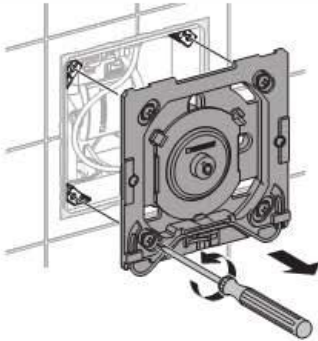

4

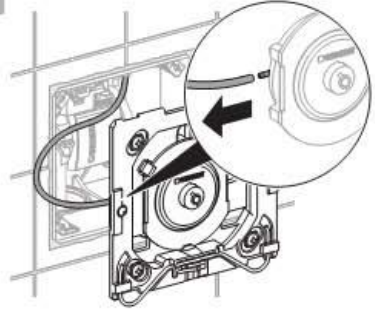

Pnömatik valfin değiştirilmesi

Koşullar

Kumanda kapağı ve montaj çerçevesi söküldü.
Bkz. "Servis, kumanda kapağının ve montaj çerçevesinin sökülmesi".

1

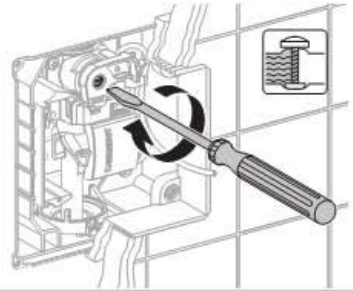

2

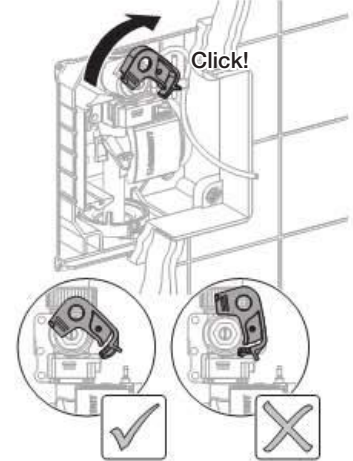

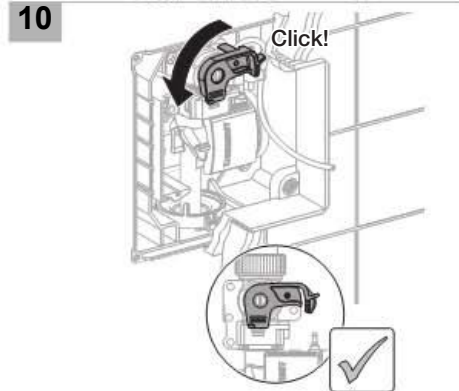
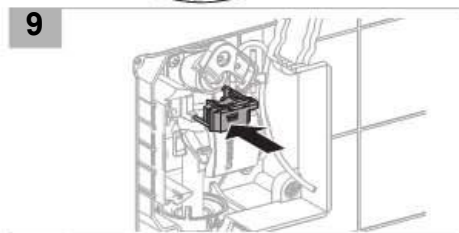
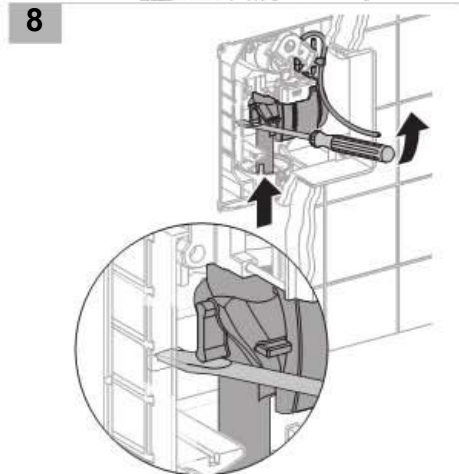
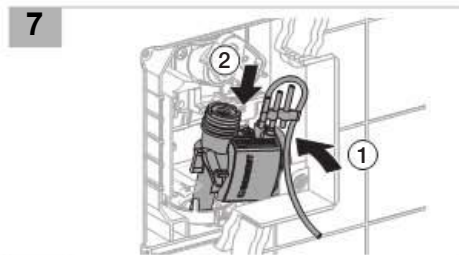
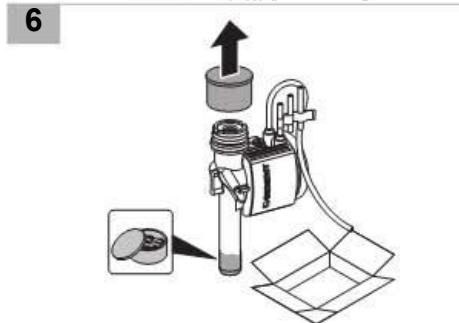
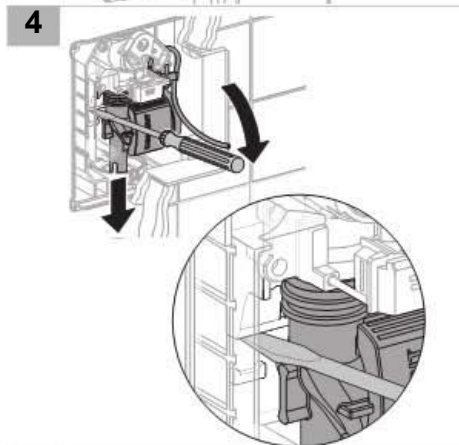
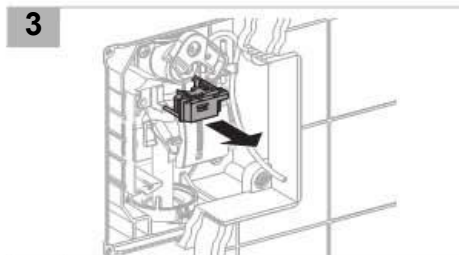

Ayar vidasının değiştirilmesi

Koşullar

Kumanda kapağı ve montaj çerçevesi söküldü.
Bkz. "Servis, kumanda kapağının ve montaj çerçevesinin sökülmesi".

1

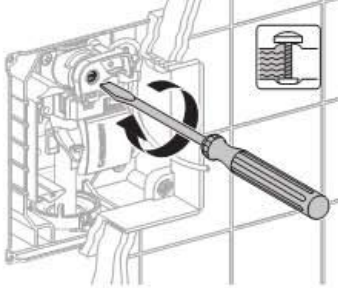

2

Ana su vanasını kapatın.

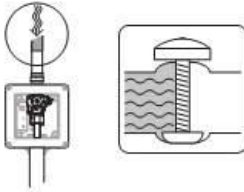

3

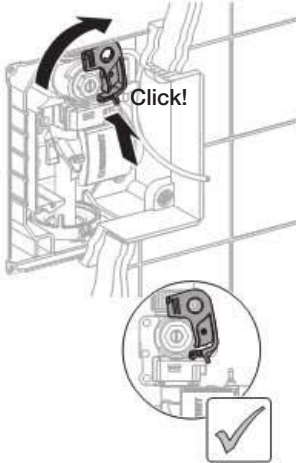

4

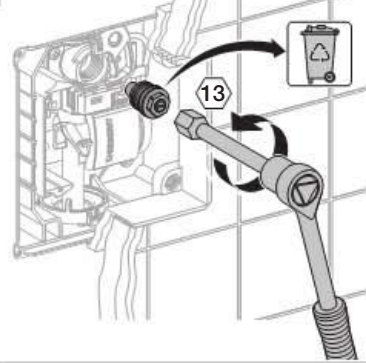

5

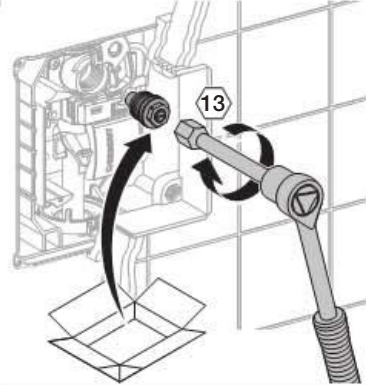

6

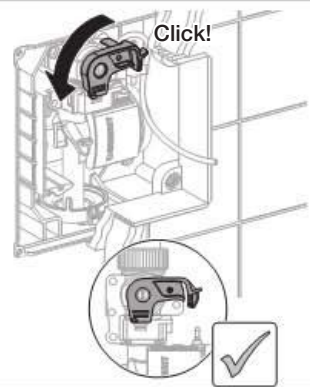

7

Ana su vanasını açın.



Yıkama hattındaki dudaklı contanın değiştirilmesi

Koşullar

Kumanda kapağı ve montaj çerçevesi söküldü.
Bkz. "Servis, kumanda kapağının ve montaj çerçevesinin sökülmesi".

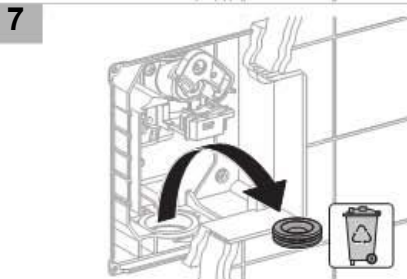
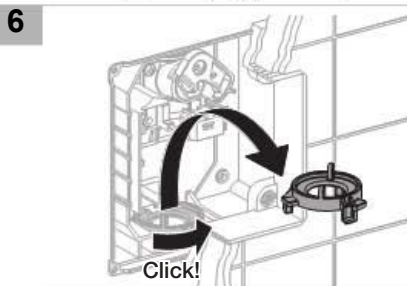
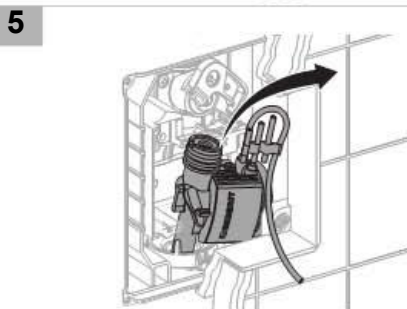
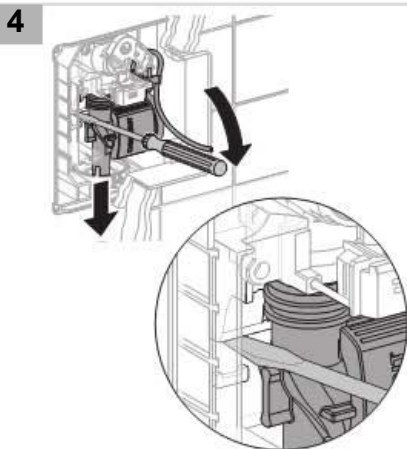
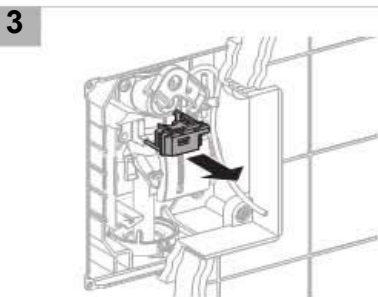
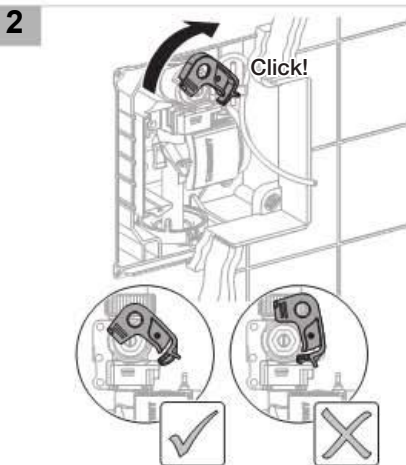
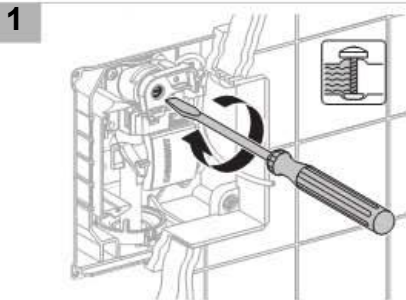

8



9

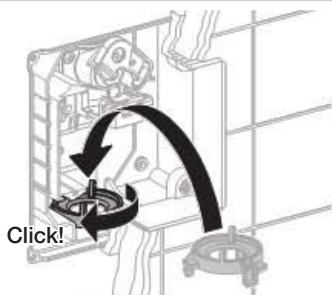

10

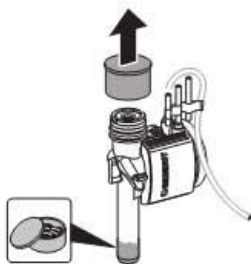

11

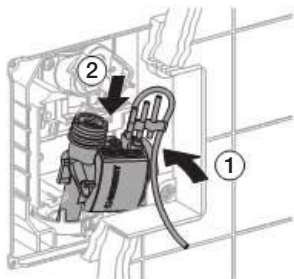

12

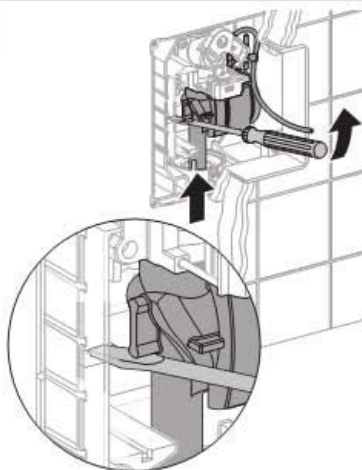

13

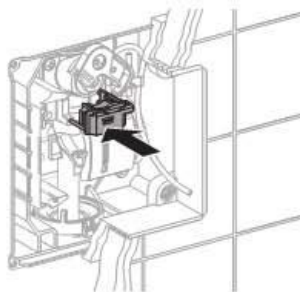

14

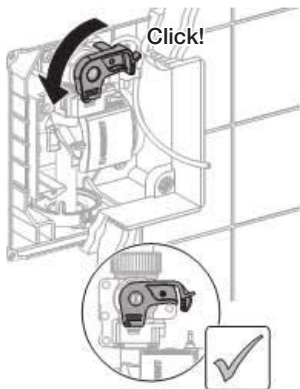

Montaj çerçevesinin ve kumanda kapağının monte edilmesi

1

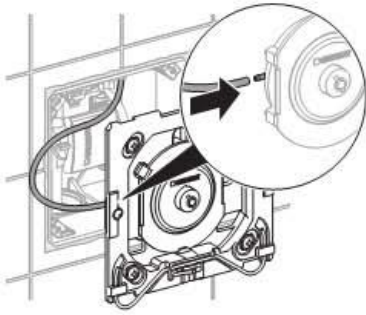

2

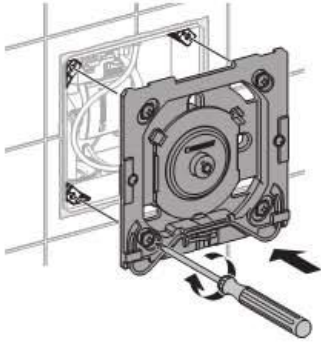

3

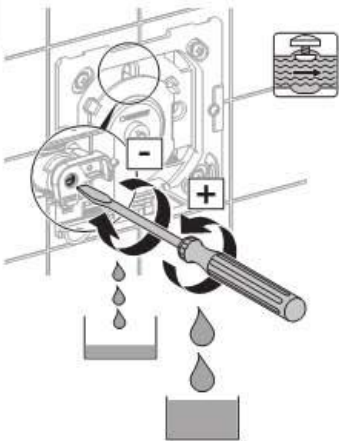

4

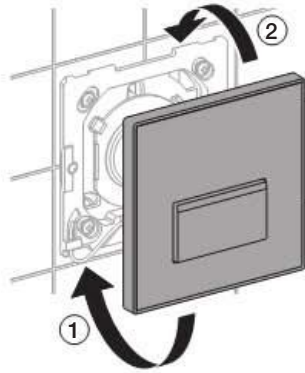

5

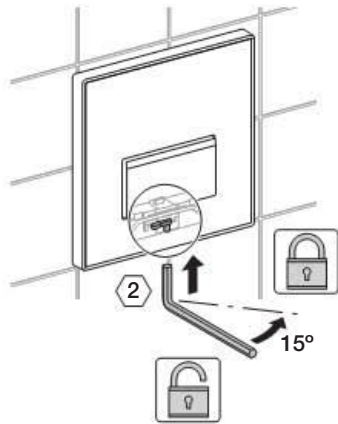

Teknik veriler**HyTouch pnömatik pisuvar deşarj kontrolü**

1 barda akış hızı	0,3 / 0,24 (akış sınırlayıcısı devrede) l/s
Su test basıncı	16 bar
Hava / asal gaz test basıncı	3 bar
Basma kuvveti	< 12 N
Akış zamanı ayar aralığı	4 / 8 / 12 s
Nem	< 100 % 100 bağıl
Çalışma sırasında basınç aralığı	1 - 8 bar
Su işletme sıcaklığı, azami	30 °C

Общая информация

Данное руководство по эксплуатации	Руководство по эксплуатации следует хранить и, если потребуется, предоставить его квалифицированному персоналу.
Эксплуатация, техобслуживание	Работы по техобслуживанию владелец может выполнять самостоятельно только в объеме, описанном в данном руководстве.
Сервисное обслуживание	Работы, связанные с сервисным обслуживанием, разрешается производить только специалисту. Неквалифицированное выполнение указанных работ может привести к несчастным случаям, материальному ущербу и неполадкам при эксплуатации.





Целевая группа

Настоящий документ предназначен для квалифицированного персонала согласно EN IEC 62079:2001.

Использование по назначению

Системы управления смывом NuTouch предназначены для смыва в керамических писсуарах. В случае использования не по назначению и при возникновении вследствие этого телесных повреждений и материального ущерба, гарантия и ответственность изготовителя теряют силу.

Пояснение символов

Символ	Значение
	ВНИМАНИЕ Указывает на возможную опасную ситуацию, которая может привести к легким и средним телесным повреждениям или материальному ущербу.
	Использовать консистентную смазку!
	Водопровод перекрыт
	Водопровод открыт

Контактная информация

При возникновении вопросов или проблем обращайтесь к официальному распространителю продукции фирмы Geberit в Вашей стране или посетите сайт www.geberit.com.

Конструкция

Пневматическая система управления смывом HyTouch

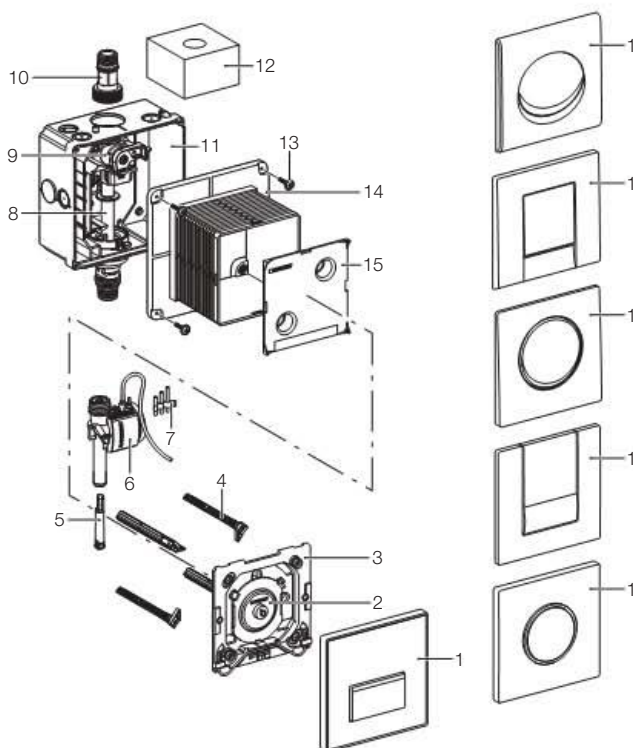

- 1 Смывная клавиша
- 2 Пневматическая кнопка
- 3 Монтажная рамка
- 4 Держатель крепления рамки
- 5 Ограничитель расхода
- 6 Пневматический клапан
- 7 Комплект форсунок
- 8 Трубка подвода
- 9 Запорный вентиль с дросселем
- 10 Присоединительный патрубок
- 11 Коробка скрытого монтажа
- 12 Защитная губка
- 13 Крепежные винты
- 14 Защитный короб
- 15 Крышка защитного короба

Техобслуживание

Периодичность технического обслуживания

Следующие работы по техобслуживанию проводить при необходимости, однако не позднее, чем через указанные интервалы времени:

- Очистка поверхности смывной клавиши – раз в неделю, выполняется владельцем
- Очистка корзинчатого фильтра – каждые 2 года, выполняется квалифицированным персоналом

Работы по техобслуживанию

Очистка пластины задействования

ВНИМАНИЕ

! Агрессивные и абразивные чистящие средства могут повредить поверхность.

- ▶ Не применять абразивные или едкие чистящие средства, содержащие хлор или кислоту. Использовать только щадящие чистящие средства и воду.



Претензии, причины которых возникли в результате использования ненадлежащих чистящих средств, могут не рассматриваться.

Очистка или замена корзинчатого фильтра



Сервисное обслуживание

Неисправности и способы устранения

Проблема	Возможная причина	Меры по устранению
Вода не течет	Перекрыт клапан подачи воды	Открыть клапан подачи воды
	Корзинчатый фильтр засорен или загрязнен	Очистить или заменить корзинчатый фильтр • См. «Техобслуживание; очистка или замена корзинчатого фильтра»
	Нет давления в водопроводе	Проверить давление воды • Восстановить давление воды
	Разъединилось разъемное соединение пневматического шланга между пневматической кнопкой и пневматическим клапаном	Подсоединить разъемное соединение пневматического шланга
	Пневматический шланг перегнут или поврежден	Заменить неисправный пневматический шланг
Постоянный расход воды (подача воды не отключается)	Пневматический клапан неисправен	Заменить пневматический клапан • См. «Сервисное обслуживание; замена пневматического клапана»
	Дроссель открыт недостаточно	Открыть дроссель
Керамический писсуар промывается недостаточно	Дроссель открыт недостаточно	Открыть дроссель
При смыве происходит разбрызгивание воды из керамического писсуара	Слишком большой расход воды	Установить ограничитель расхода • Ограничитель расхода можно заказать как принадлежность (242.484.00.1)

Работы по сервисному обслуживанию

В данном руководстве по сервисному обслуживанию описывается система управления с вертикальным водопроводом (А). Система управления с горизонтальным водопроводом (В) в данном руководстве не отображается, однако работы по ее сервисному обслуживанию проводятся аналогично.

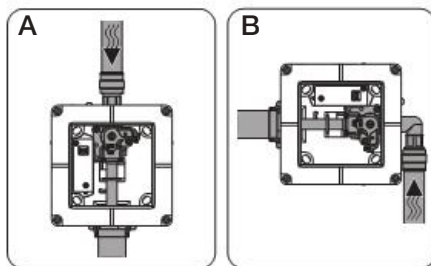

Далее описаны следующие работы по сервисному обслуживанию:

- Демонтаж смывной клавиши и монтажной рамки
- Замена пневматического клапана
- Замена регулирующего винта
- Замена манжетного уплотнения смывного трубопровода
- Установка монтажной рамки и смывной клавиши

Демонтаж пластины задействования и монтажной рамки

1

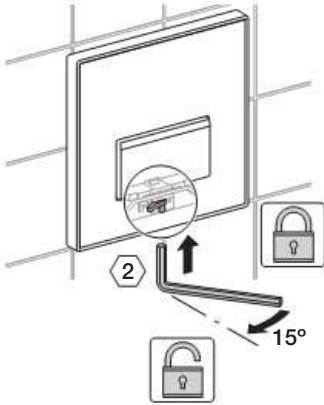

2

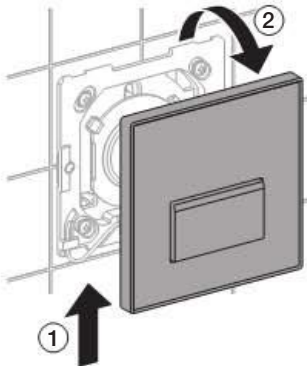

3

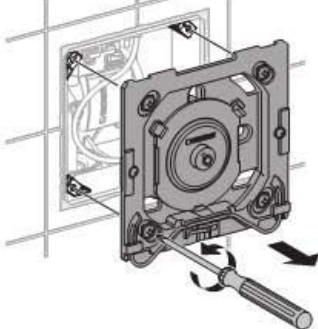

4

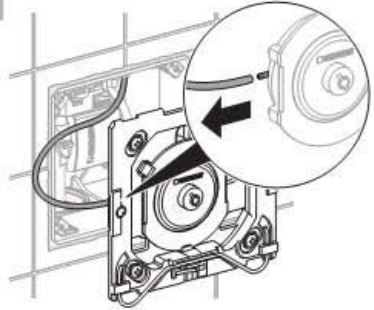

Замена пневматического клапана

Необходимые условия

Смывная клавиша и монтажная рамка демонтированы.

См. «Сервисное обслуживание; демонтаж смывной клавиши и монтажной рамки».

1

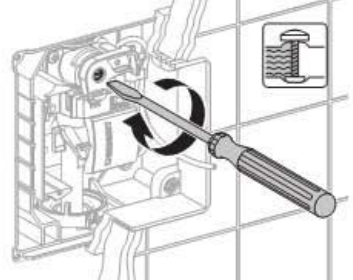

2

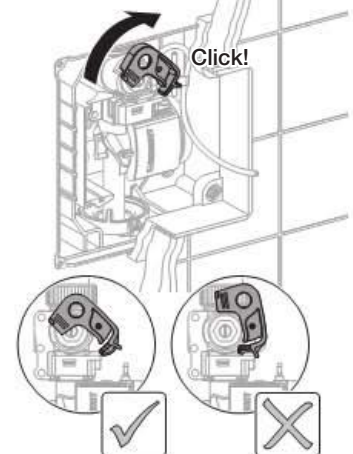

3

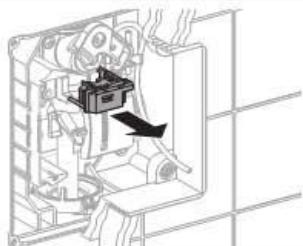

4

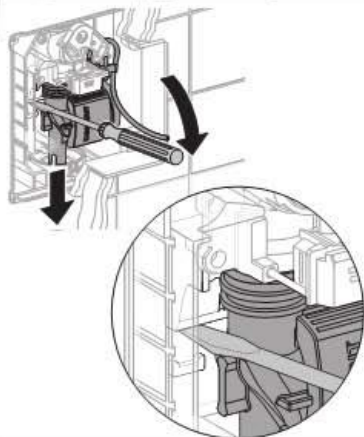

5

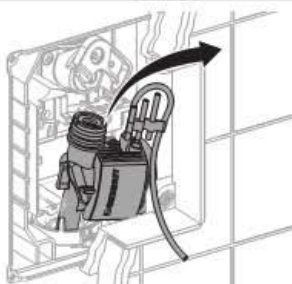

6

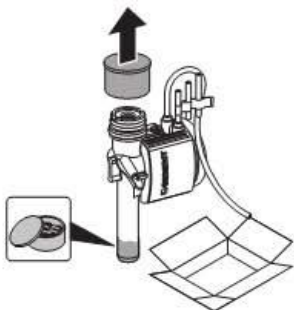

7

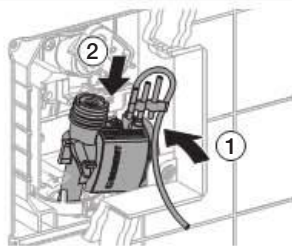

8

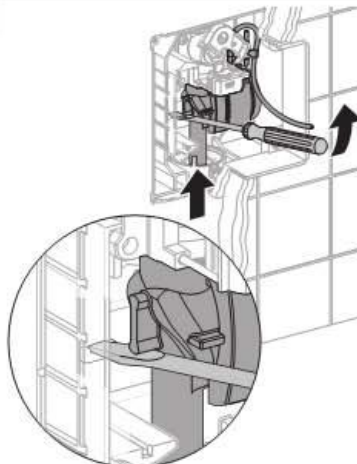

9

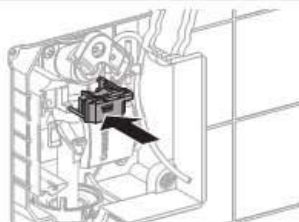

10

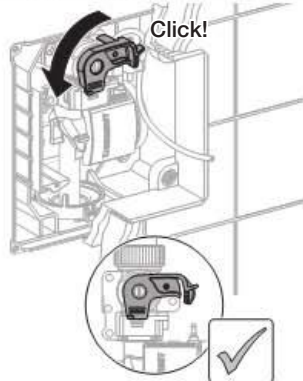

Замена регулирующего винта

Необходимые условия

Смывная клавиша и монтажная рамка демонтированы.

См. «Сервисное обслуживание; демонтаж смывной клавиши и монтажной рамки».

1

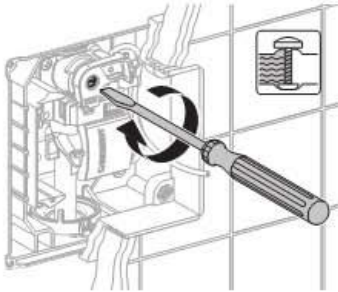

2

Закреть клапан централизованной подачи воды.

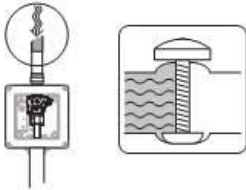

3

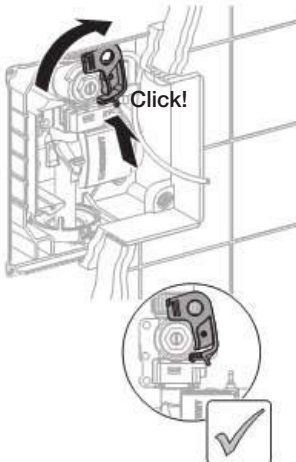

4

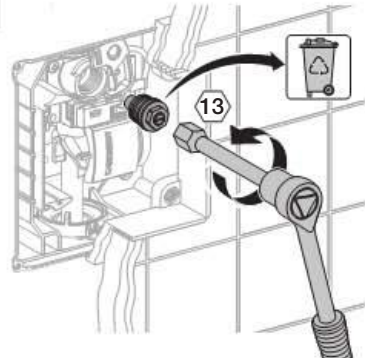

5

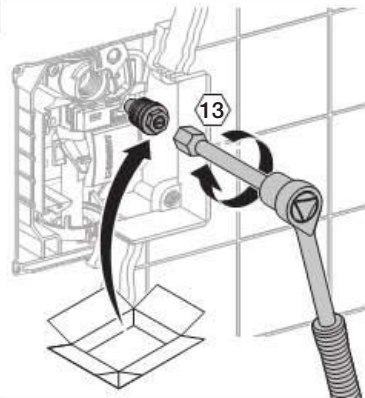

6

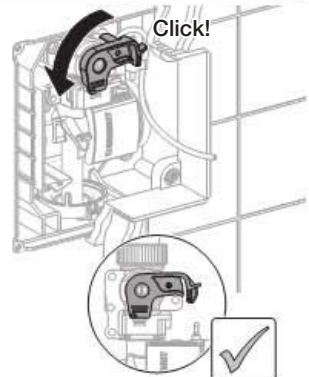

7

Открыть клапан централизованной подачи воды.



Замена манжетного уплотнения смывного трубопровода

Необходимые условия

Смывная клавиша и монтажная рамка
демонтированы.

См. «Сервисное обслуживание; демонтаж
смывной клавиши и монтажной рамки».

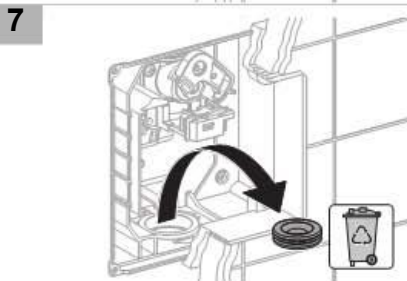
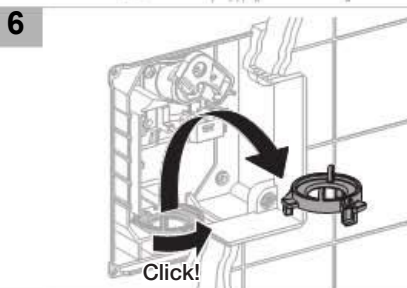
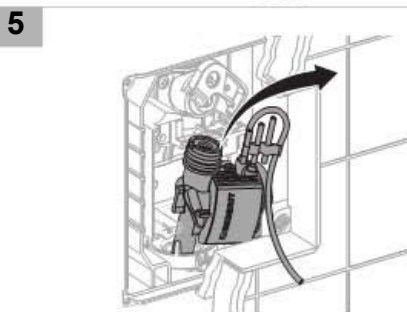
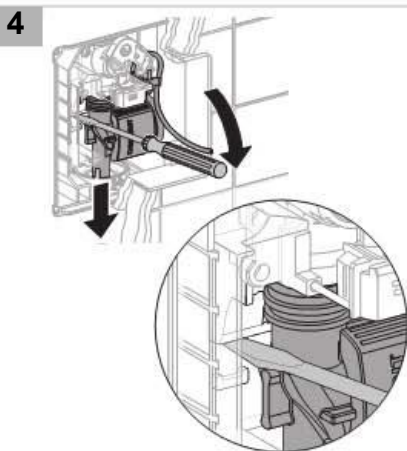
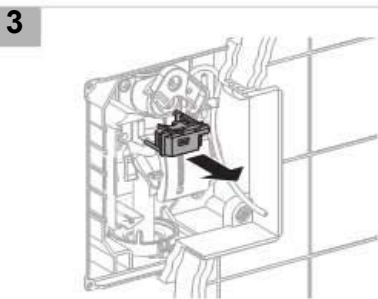
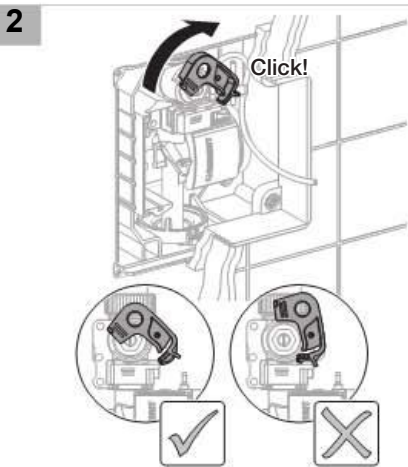
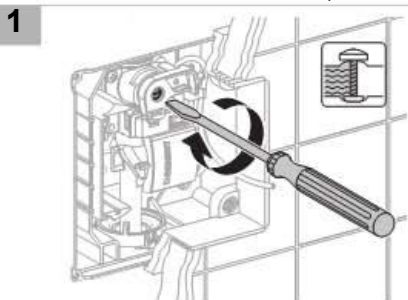

8



9

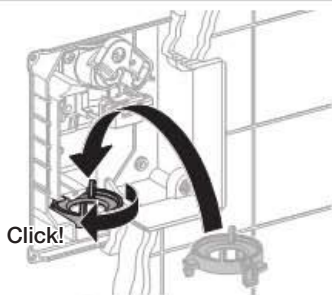

10

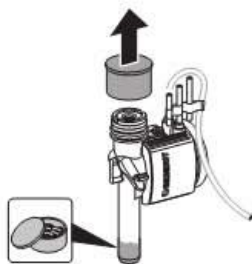

11

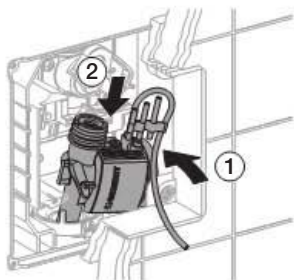

12

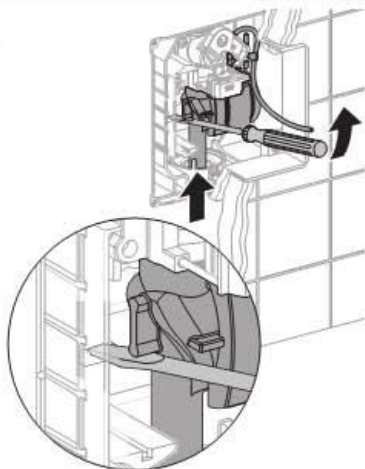

13

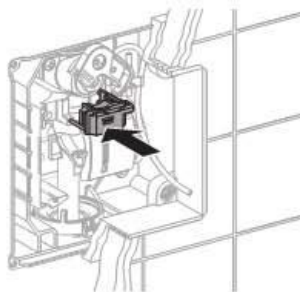

14

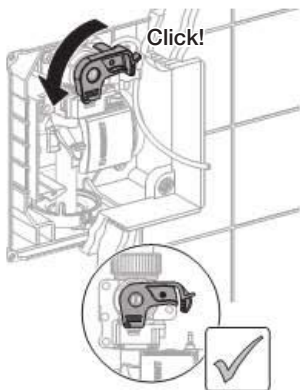

Установка монтажной рамки и
смывной клавиши

1

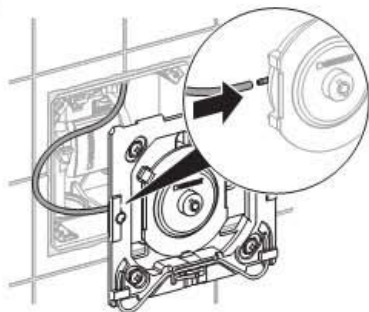

2

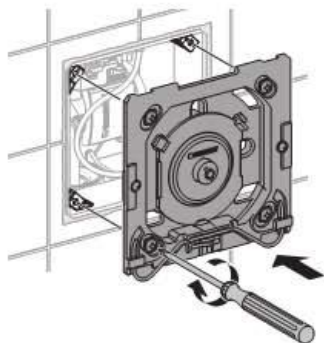

3

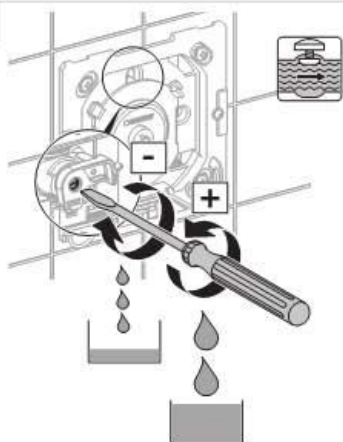

4

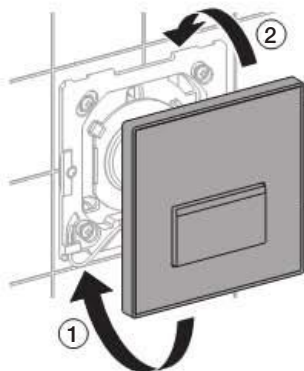

5

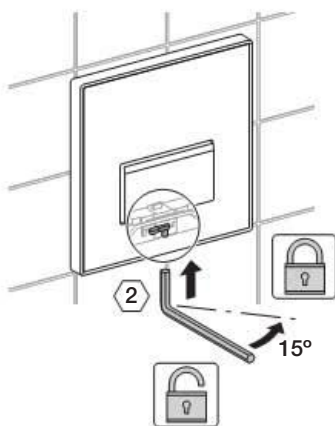

Технические данные

Пневматическая система управления смывом NuTouch

Расход воды при 1 бар	0,3 / 0,24 (с ограничителем расхода)	л/сек
Испытательное давление воды	16	бар
Испытательное давление воздуха/инертного газа	3	бар
Усилие привода	< 12	Н
Продолжительность смыва	4 / 8 / 12	сек
Макс. относительная влажность	< 100	%, относительная
Рабочий диапазон давления	1 - 8	бар
Максимальная температура воды	30	°C

一般性提示

本操作指导手册	请好好保存本操作指导手册，必要时提供给专业人员参阅。
使用，维护	只允许由营运商按照本指导手册规定的要求来完成本小便冲洗阀上的维护工作。
维修服务	只允许由专业人员来完成维修服务工作。操作不当会引发事故，导致财产受损和影响使用。

目标群体

按照 EN IEC 62079:2001 标准，本文件针对专业人员。

按照规定使用

HyTouch 型小便冲洗阀专用于冲洗陶瓷小便池。如果用于其他用途，制造商将一律拒绝用户因人员受伤和财产受损而提出的赔偿要求并免除任何责任。

标记注释

标记	含义
	小心 提示可能存在会导致人身轻度或中度受伤或使财产受损的危险。
	请使用润滑脂！
	水管已停水
	水管已接通

联系方式

如有疑问或疑难，请与主管您所在地的 Geberit 经销商联系或通过 www.geberit.com 查询。

HyTouch 型气动小便冲洗阀

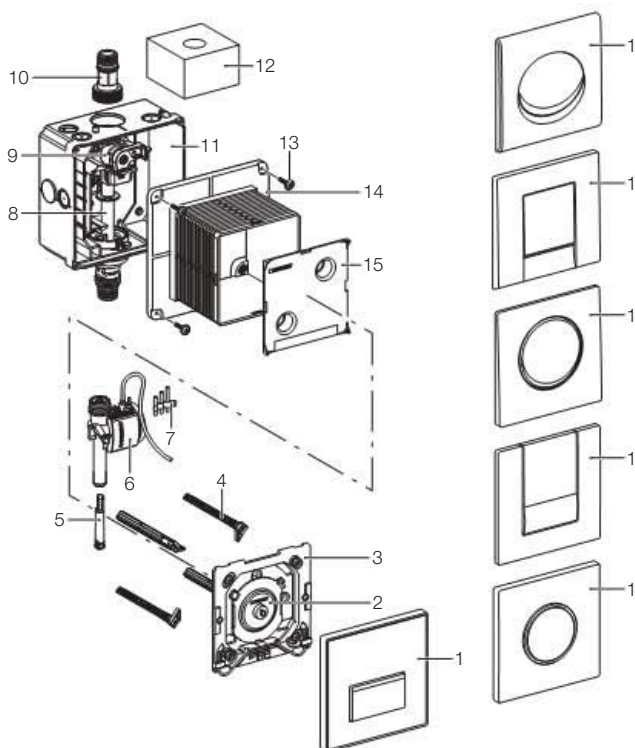

- 1 操作面板
- 2 气动按钮
- 3 固定框架
- 4 间距调整螺栓
- 5 流量限制器
- 6 气动阀
- 7 喷嘴组
- 8 空管
- 9 带有节流调节阀的截止阀
- 10 接头
- 11 暗装盒
- 12 保护海棉
- 13 固定螺钉
- 14 建筑体护件
- 15 建筑体护盖

维护

维护周期

需要时，但最迟应在规定的时间周期内完成以下维护工作：

- 营运商应每周清洁操作面板的表面一次
- 应由专业人员每两年清洁滤网一次

维护工作

清洁操作面板



注意

侵蚀性的和摩擦性的清洁剂会损坏表面。

- ▶ 切勿使用含氯的，酸性的，打磨的或侵蚀性的清洁剂，只允许使用温和型清洁剂和水



我们不承认用户因清洁剂使用不当而引起的投诉。

清洁或更换滤网



维修服务

寻找故障

出现的问题	可能的原因	补救措施
水流不出	供水龙头已关闭	打开供水龙头
	滤网堵塞了或脏了	清洁或更换滤网 - 参见“维护, 清洁或更换滤网”部分
	供水网络中没有压力	检查水压 - 重新建立水压
	在气动按钮和气动阀之间的气动软管的接插连接被切断了	建立气动软管的接插连接
	气动软管被折弯或已断裂	更换损坏了的气动软管
	气动阀坏了	更换气动阀 - 参见“维修服务, 更换气动阀”部分
水流不止	气动阀坏了	更换气动阀 - 参见“维修服务, 更换气动阀”部分
未彻底冲洗陶瓷小便池	节流调节阀开得太小	打开节流调节阀
冲洗水从陶瓷小便池中溅出	流量太高	安装流量限制器 - 流量限制器可以作为配件购得 (242.484.00.1)

维修服务工作

维修服务说明书中介绍的是配有垂直导水管的冲洗阀 (A)。虽然没有介绍配有水平导水管的冲洗阀 (B), 不过, 其维修服务工作是相同的。

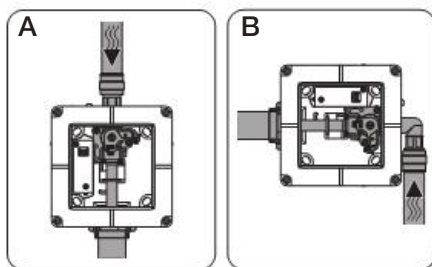

这里描述的是以下维修服务工作:

- 拆下操作面板和固定框架
- 更换气动阀
- 更换节流螺钉
- 更换冲洗管道内的唇型密封圈
- 安装固定框架和操作面板

拆下操作面板和固定框架

1

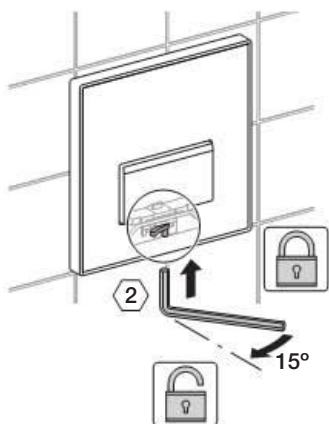

2

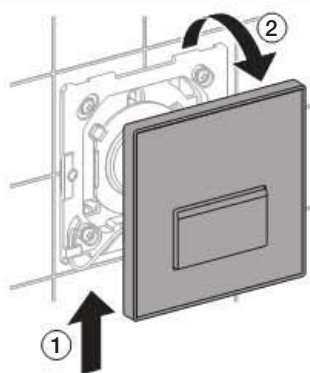

3

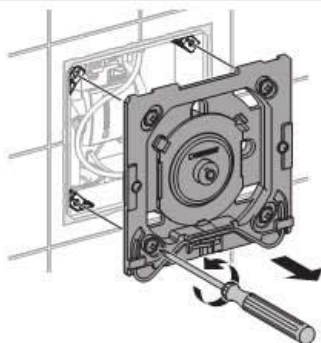

4

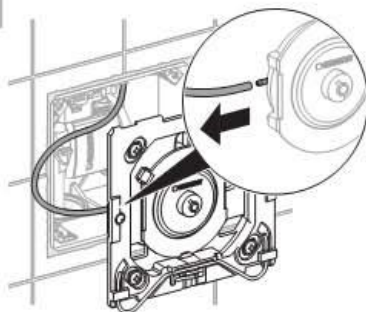

更换气动阀

前提条件

操作面板和固定框架已拆下。

参见“维修服务，拆下操作面板和固定框架”部分。

1

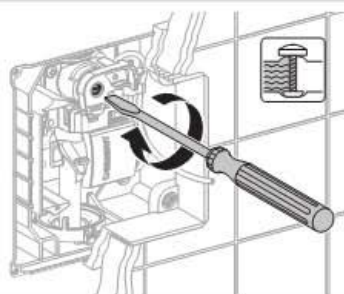

2

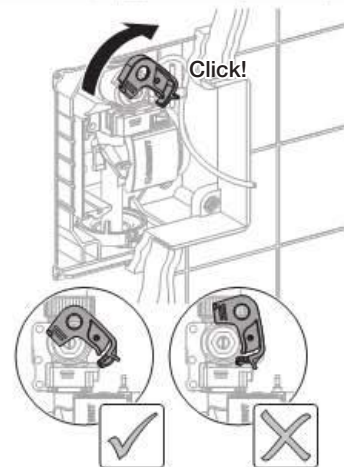

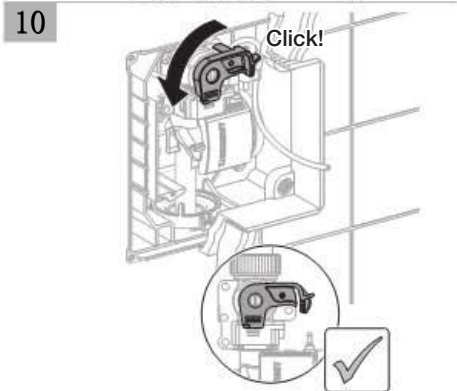
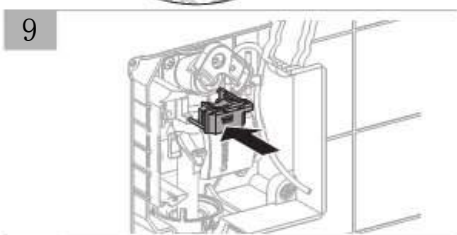
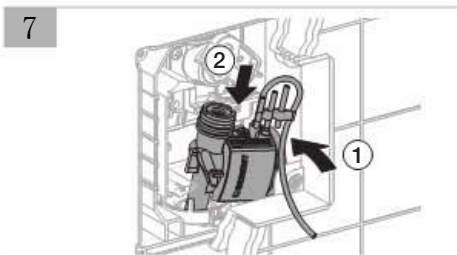
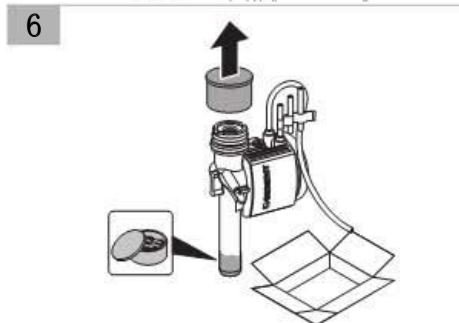
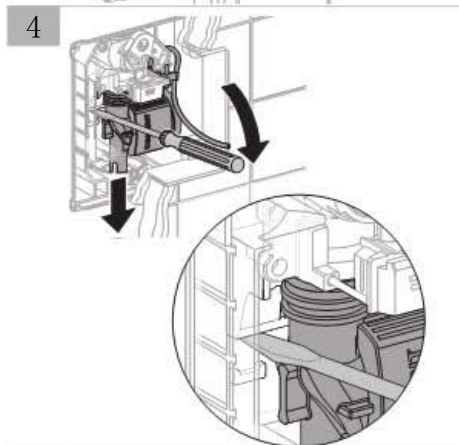
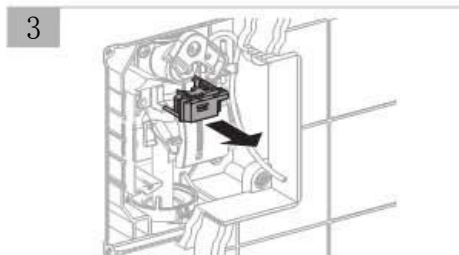

更换节流螺钉

前提条件

操作面板和固定框架已拆下。

参见“维修服务，拆下操作面板和固定框架”部分。

1

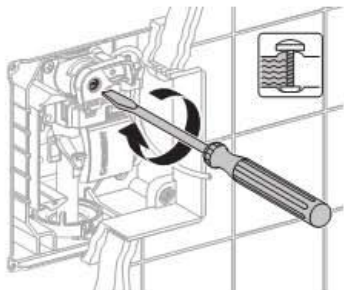

2

关闭总供水龙头。

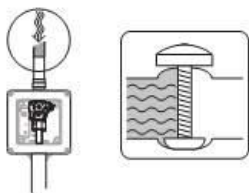

3

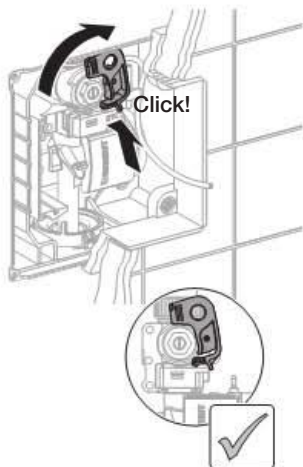

4

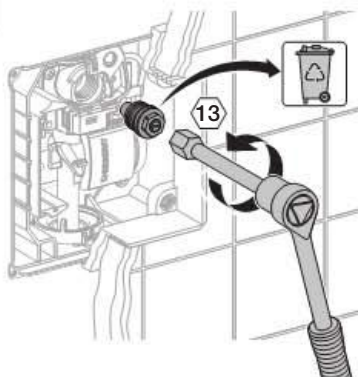

5

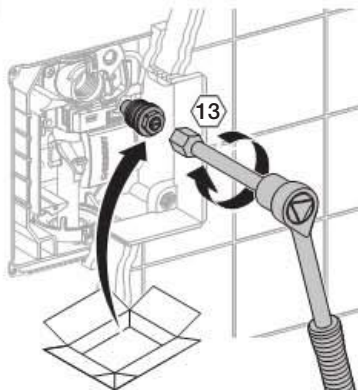

6

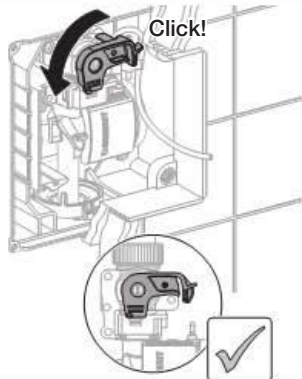

7

打开总供水龙头。



更换冲洗管道内的唇型密封圈

前提条件

操作面板和固定框架已拆下。

参见“维修服务，拆下操作面板和固定框架”部分。

1

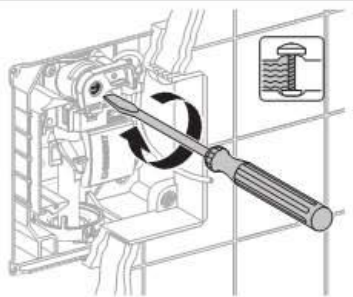

2

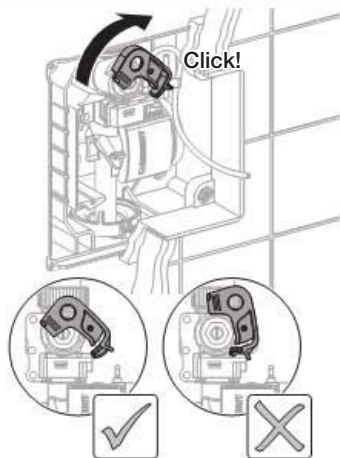

3

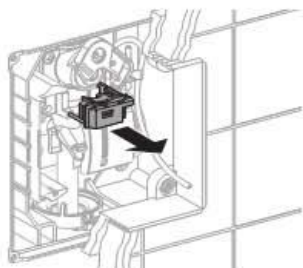

4

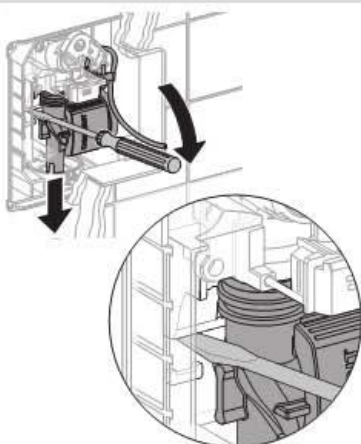

5

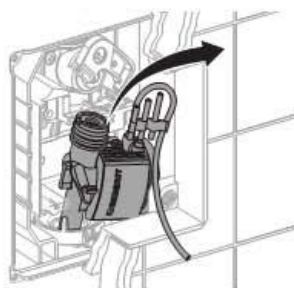

6

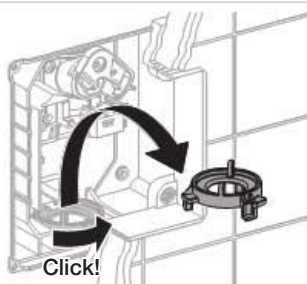

7

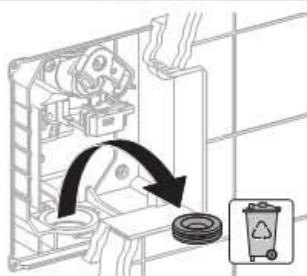

8



9



10

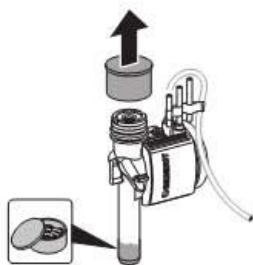

11

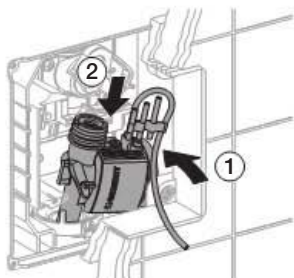

12

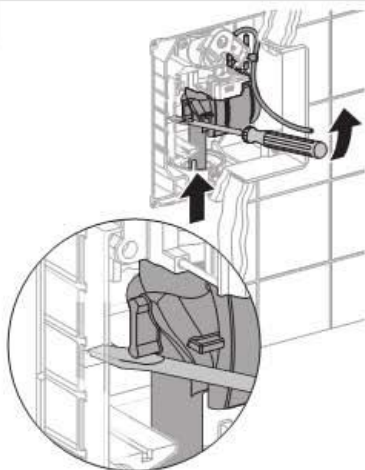

13

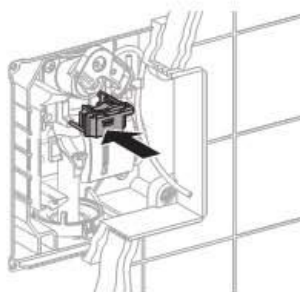

14

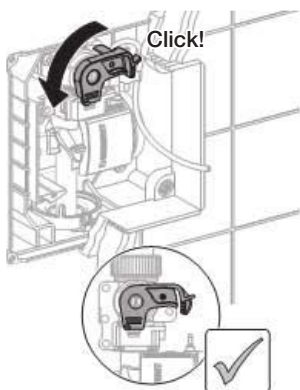

安装固定框架和操作面板

1

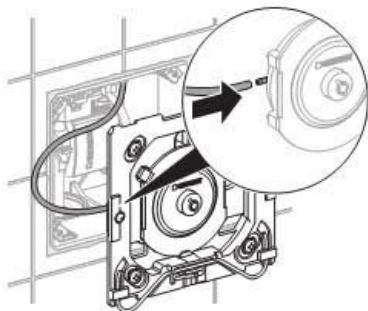

2

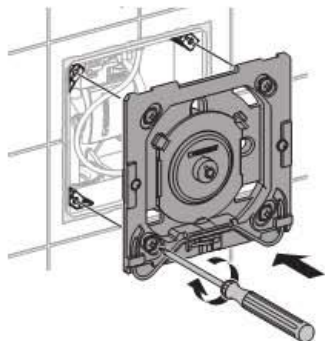

3

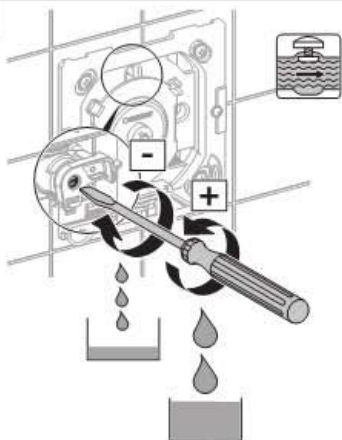

4

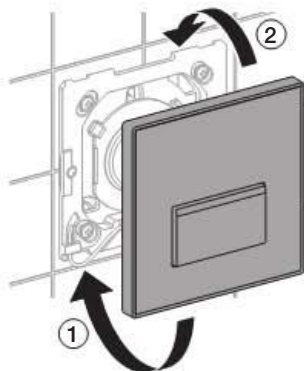

5

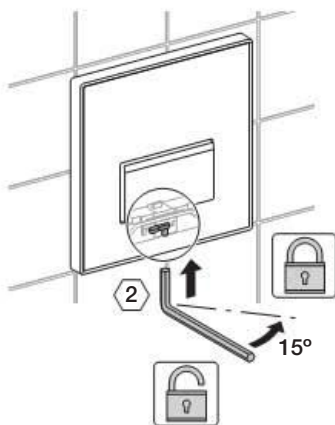

技术数据

HyTouch 型气动小便冲洗阀

1 巴时的流通量	0.3 / 0.24 (含流量限制器) l/s
水的检验压力	16 bar
空气 / 惰性气体的检验压力	3 bar
操作力	< 12 N
冲洗时间的调节范围	4 / 8 / 12 s
空气湿度	< 100 相对 %
工作压力范围	1 - 8 bar
最高水运行温度	30 ° C

Geberit International AG
Schachenstrasse 77
CH-8645 Jona



www.geberit.com
dokumentation@geberit.com